

DORADO SCHEMATICS

Memory Data Board

(1k chip version)

Table of contents

<u>TITLE</u>	<u>Page</u>
Bit slice 00 and its control	01
D memory addresses	02
Control, D memory CE's and Write's	03
Hamming code generator	04
Hamming code checker	05
Error corrector and Pipe4	06
Bit slices 01	07
02-03	08
04-05	09
06-07	10
08-09	11
10-11	12
12-13	13
14-15	14
16-17	15
D memory addressing, bits 01-05	16
06-10	17
11-15	18
16-17	19
Bit slice control, bits 01-17	20
Midas control and multiplexers	21
Clock distribution	22
Layout	23

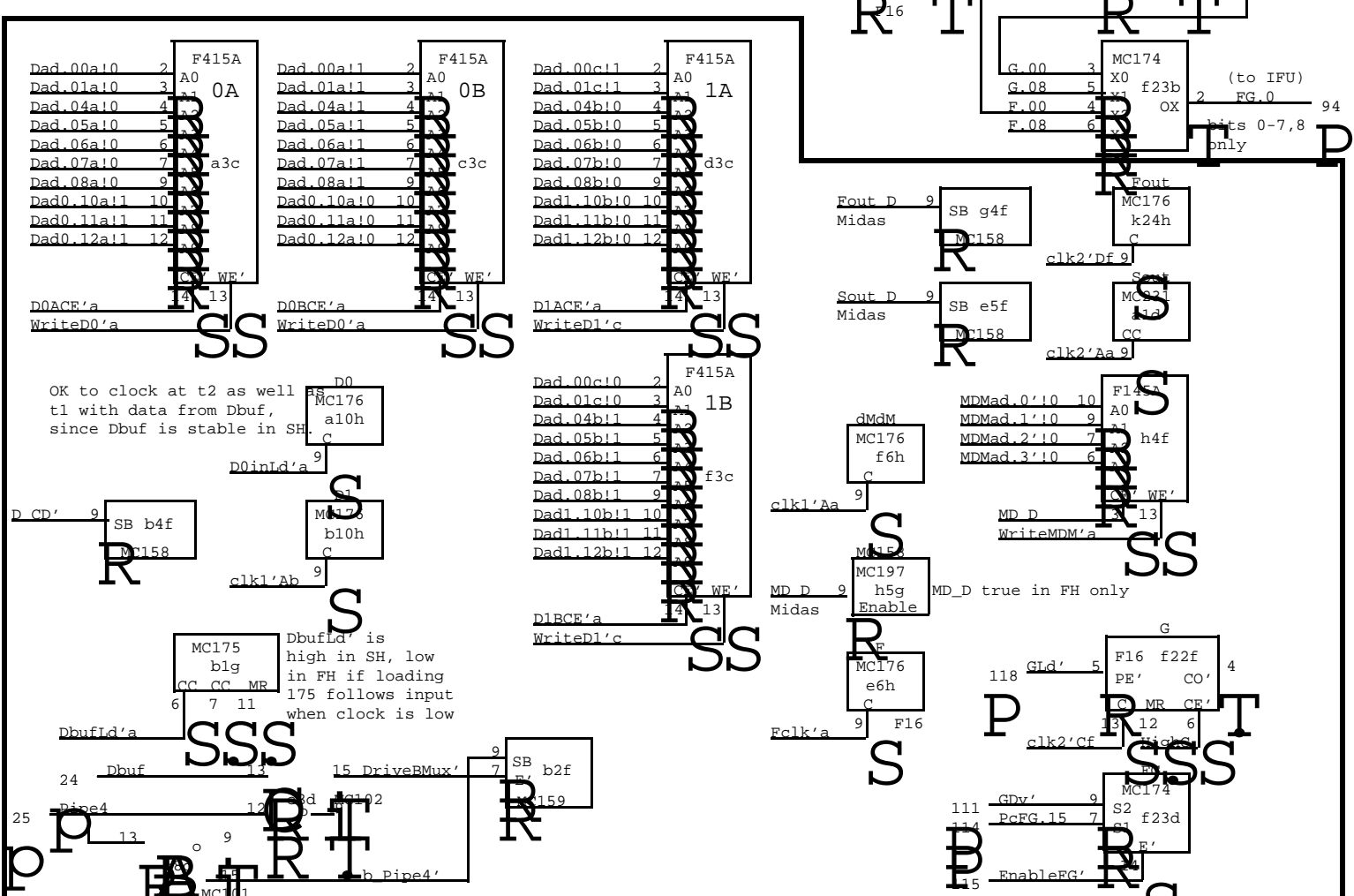
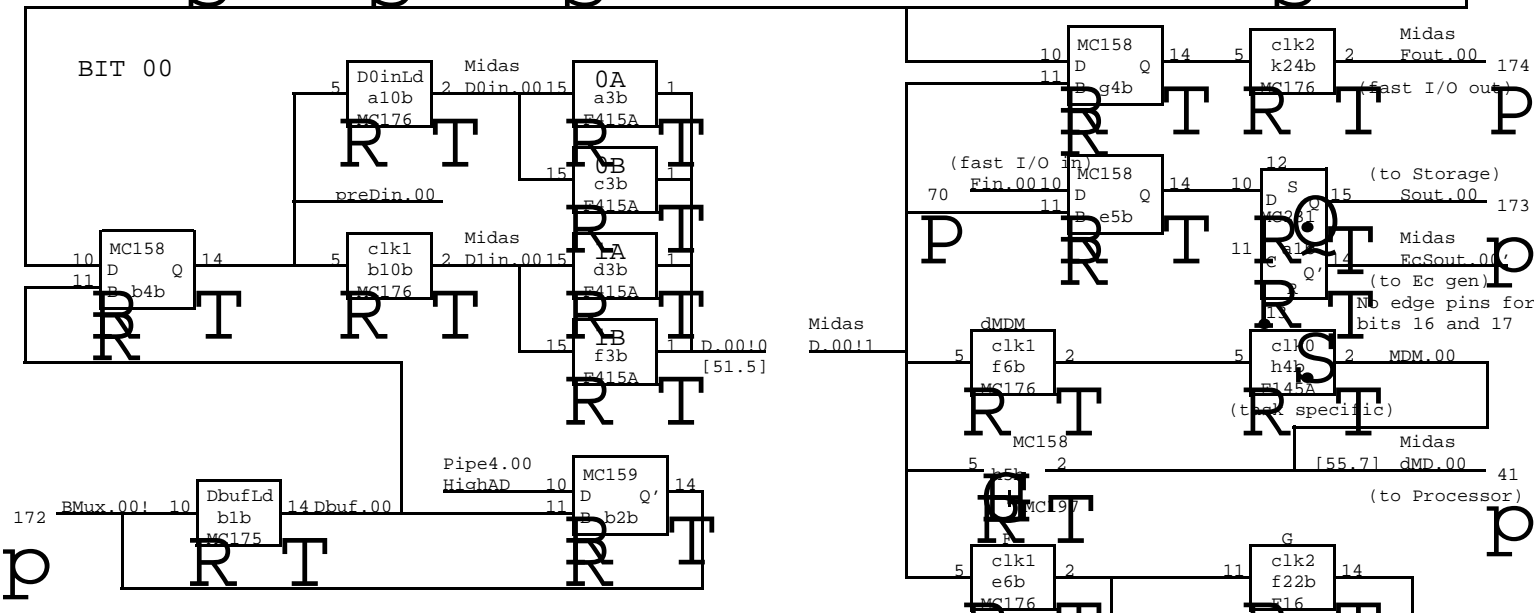
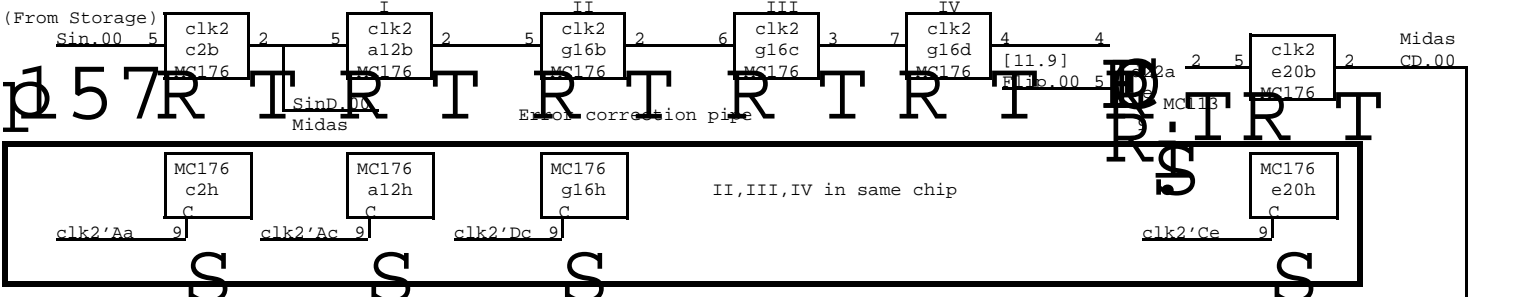

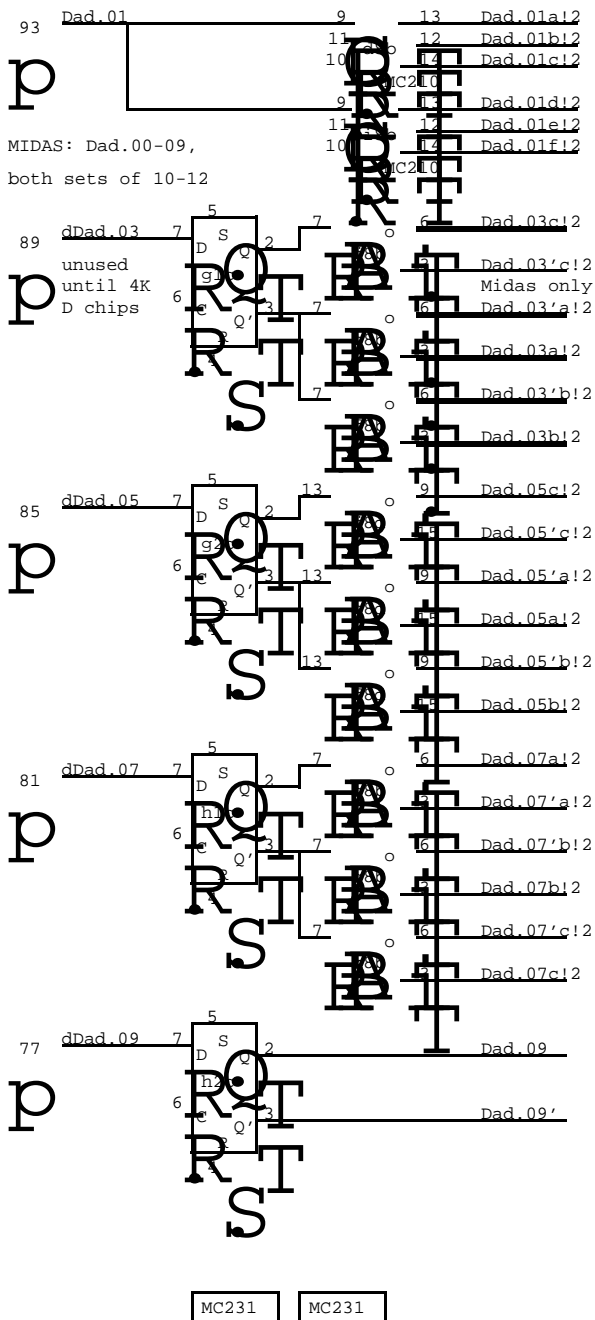
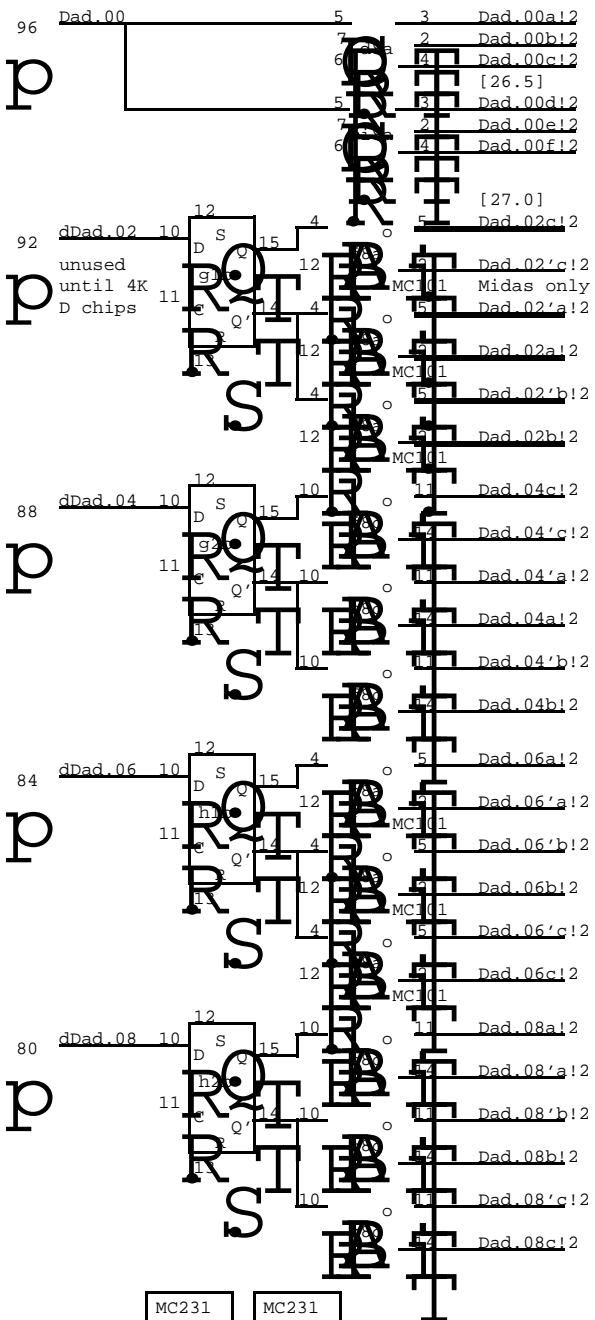

MIDAS: Dad.00-09,
both sets of 10-12

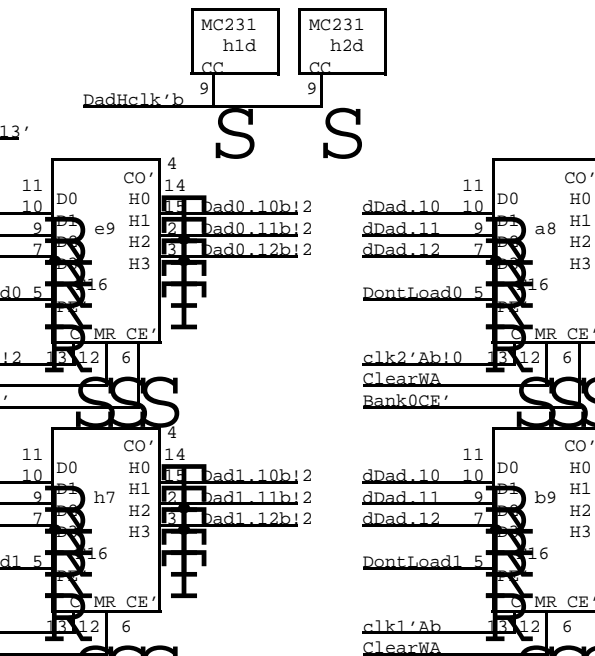
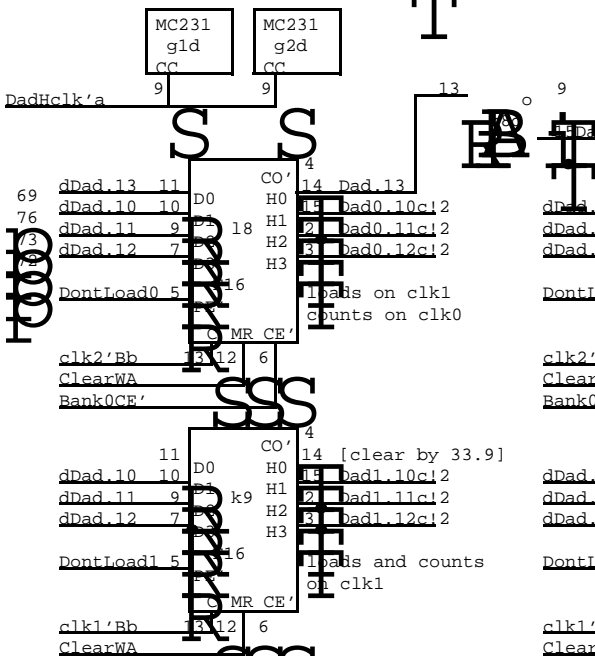

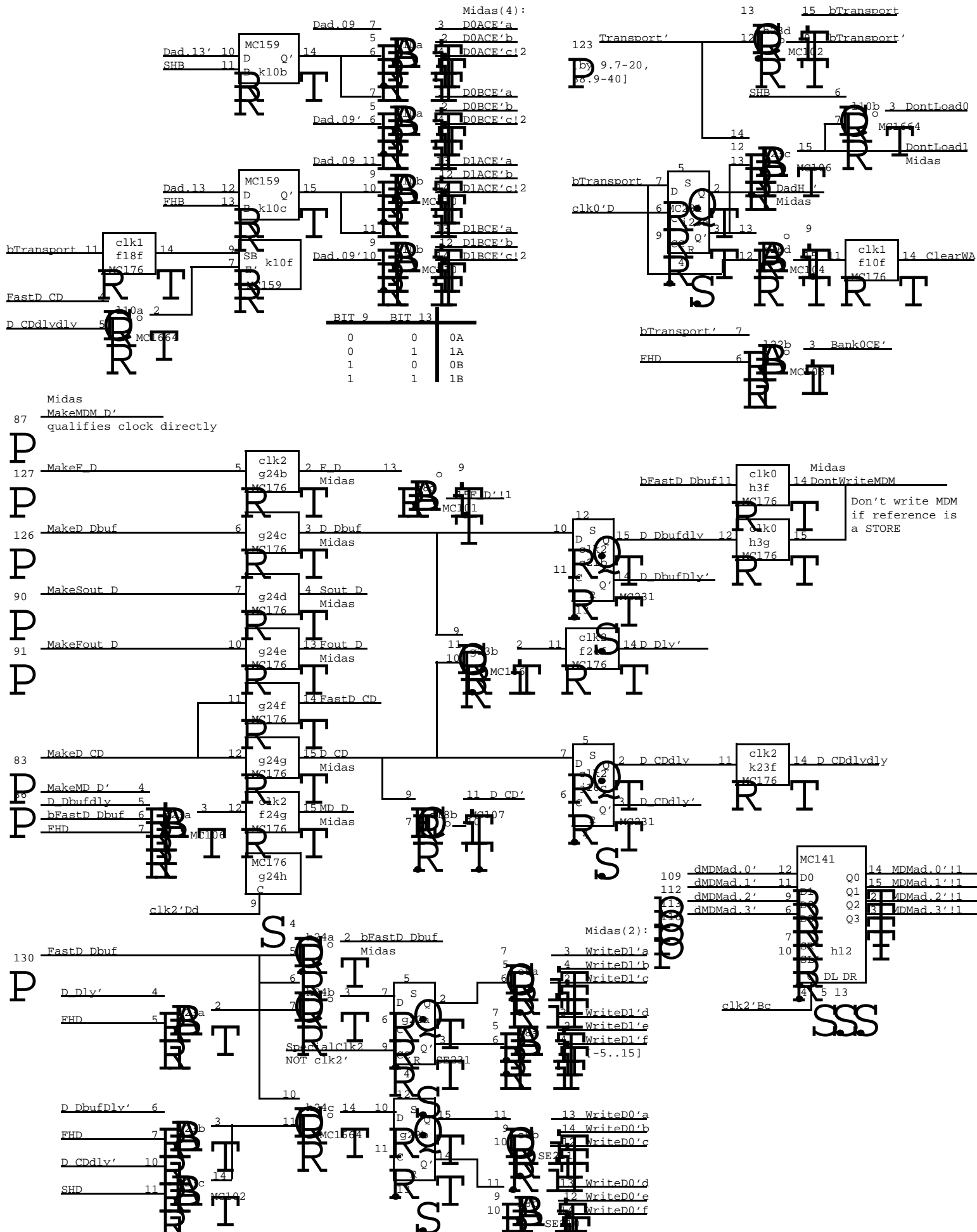

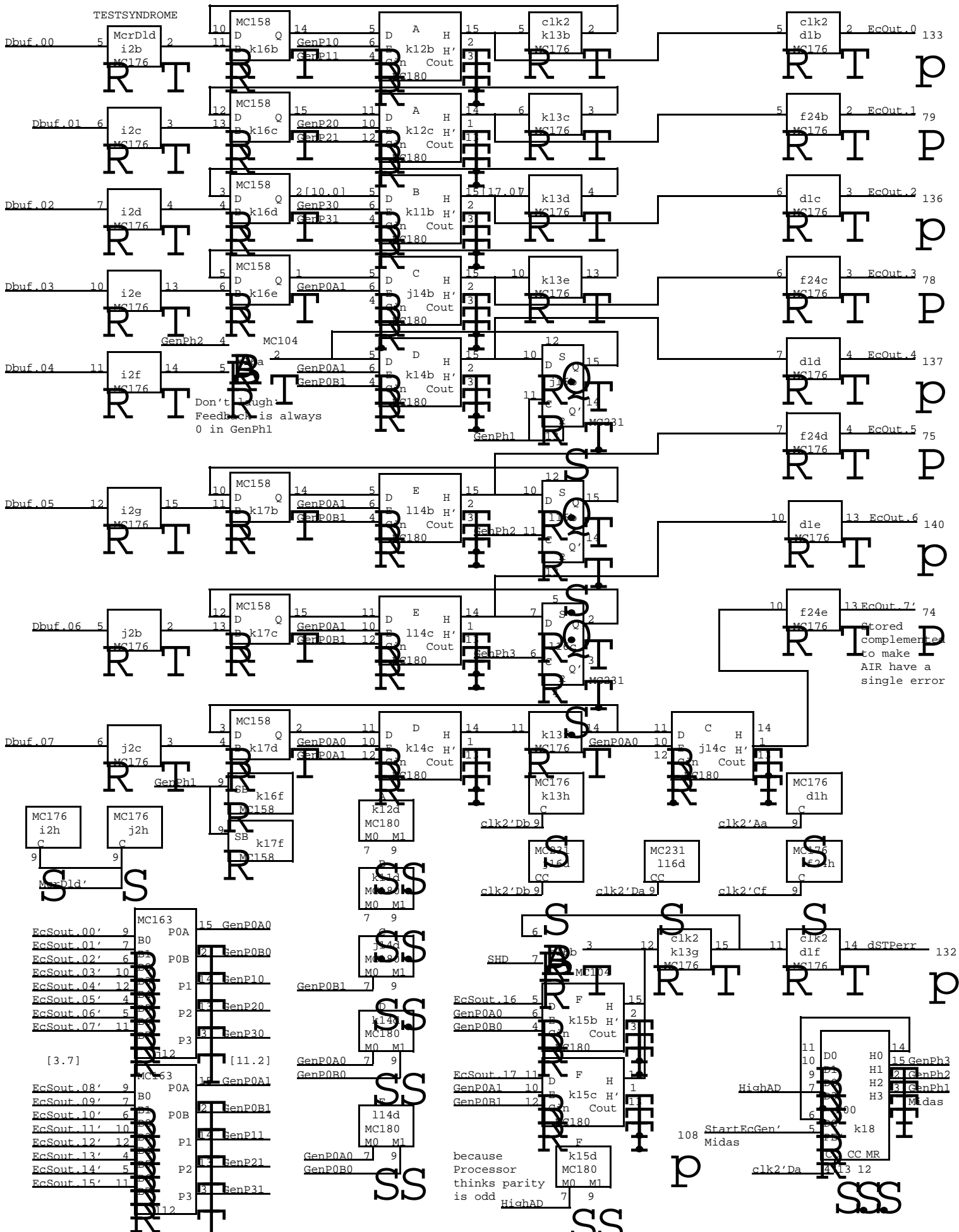

XEROX PARC/CSL	Project Dorado	Memory data board Hamming code generator	File MemD04.sil	Designer D. Clark	Rev Da	Date 7/31/79	Page 04
-------------------	-------------------	---	--------------------	----------------------	-----------	-----------------	------------

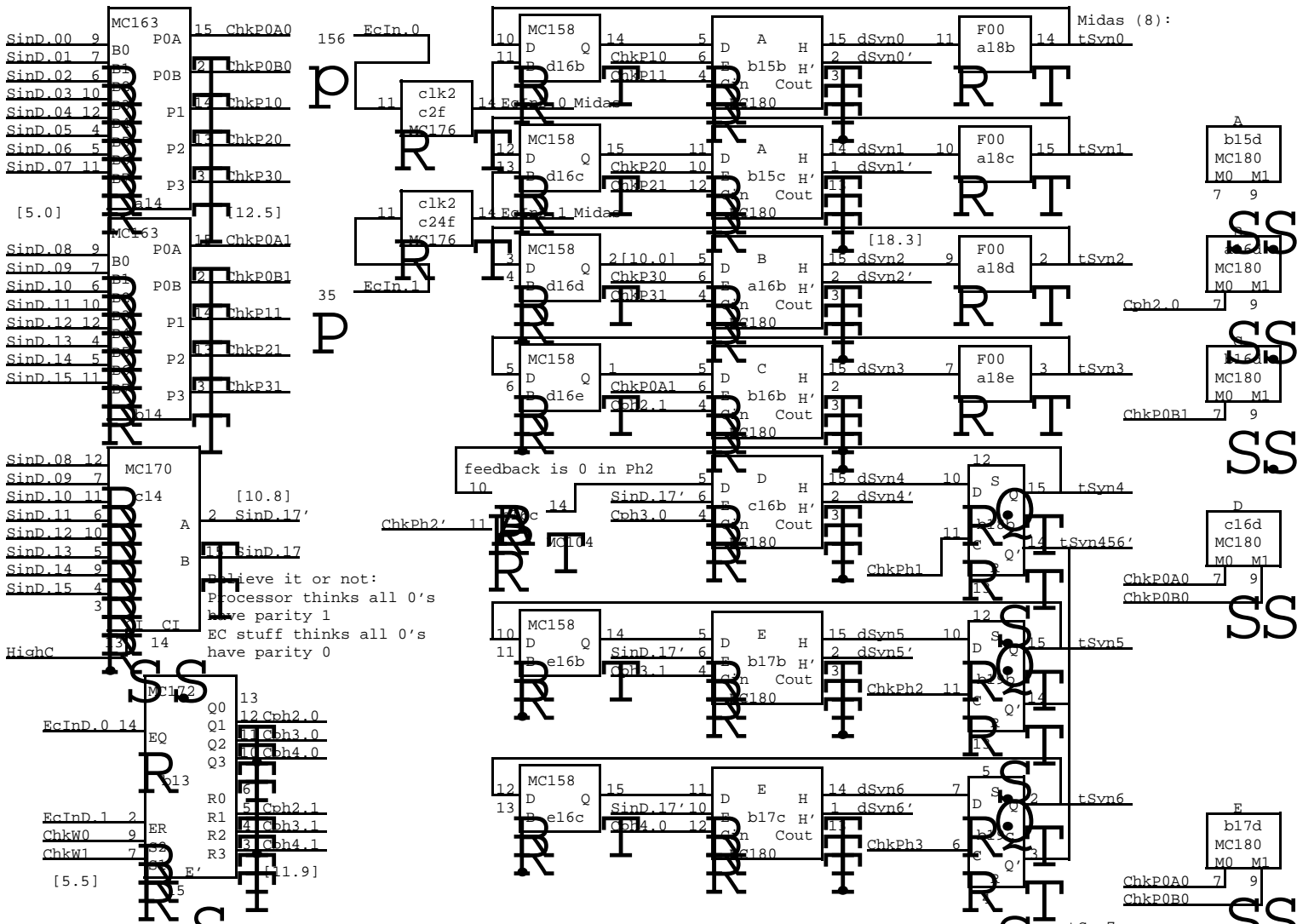

Note: the MC180 is a dual 5-input xor gate, in which the M0 and M1 inputs are common.

Stored Ci are retrieved two at a time, and xored into the syndrome as they arrive. The Cph1.0/1 signals are the arriving Ci in the proper phase, 0 otherwise

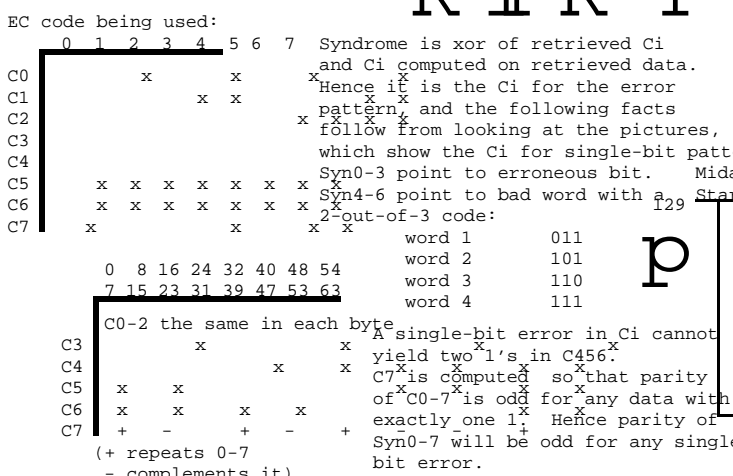
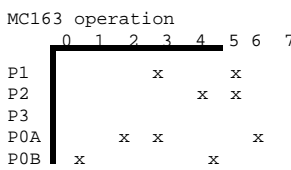

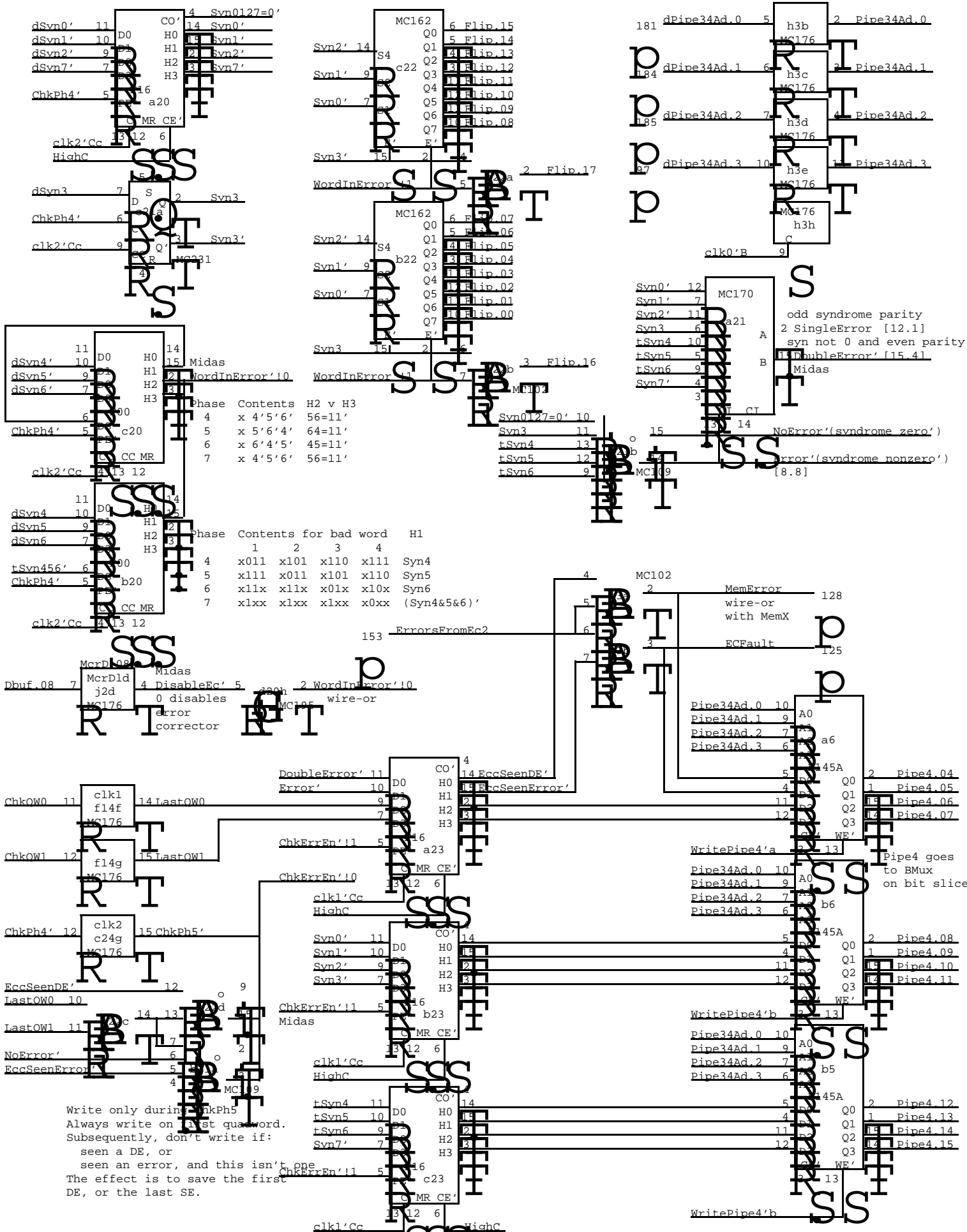

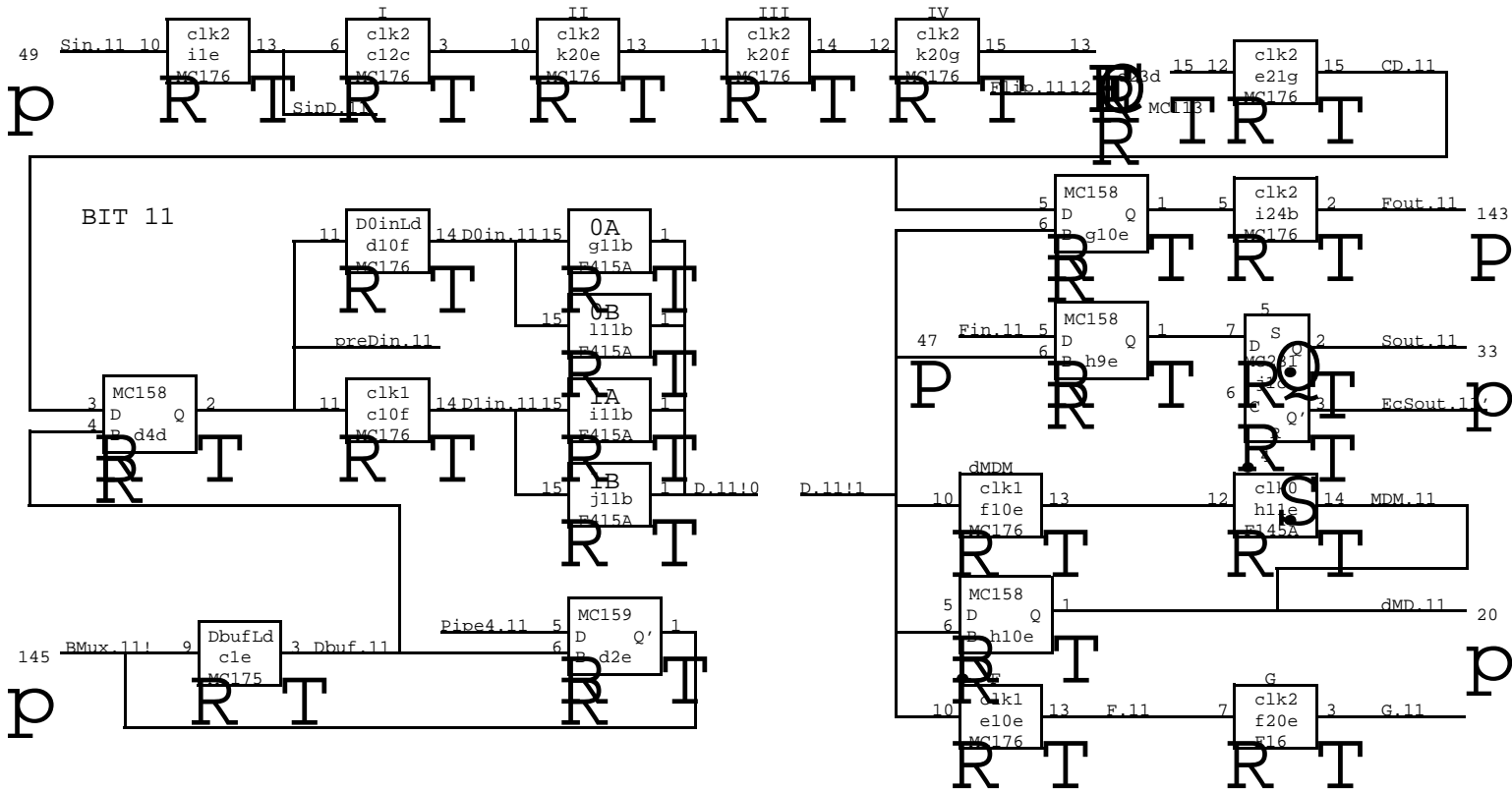
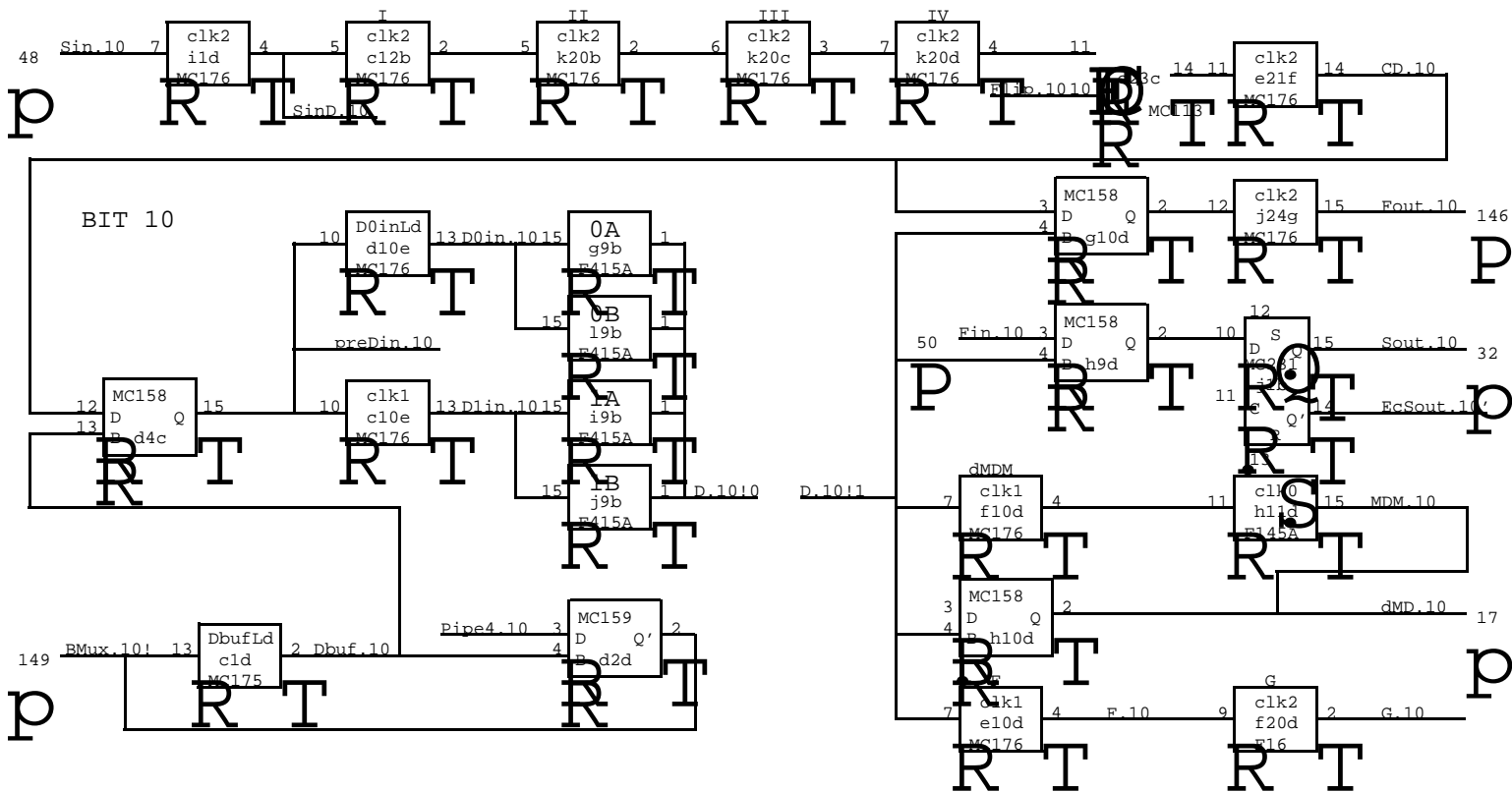

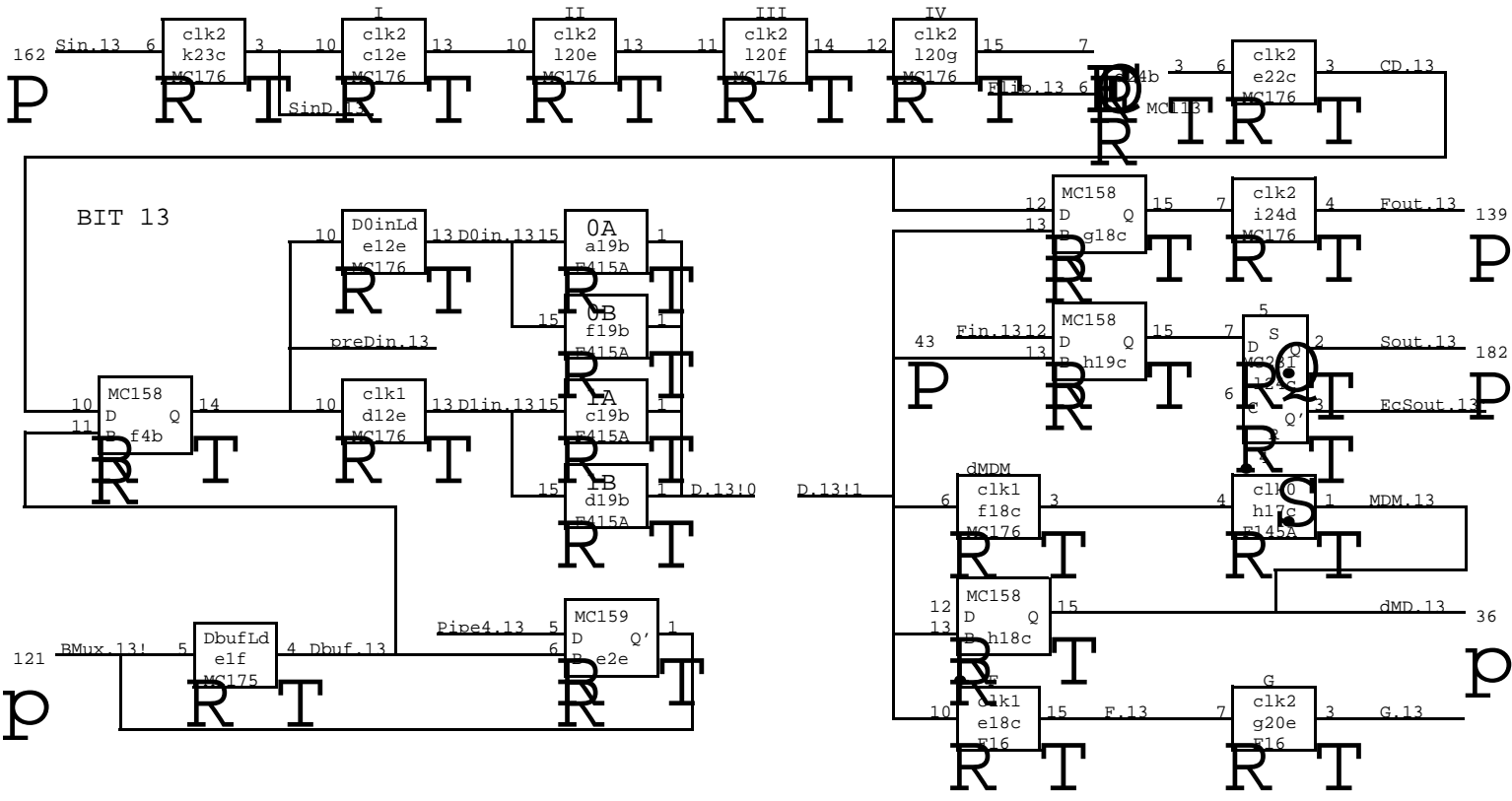
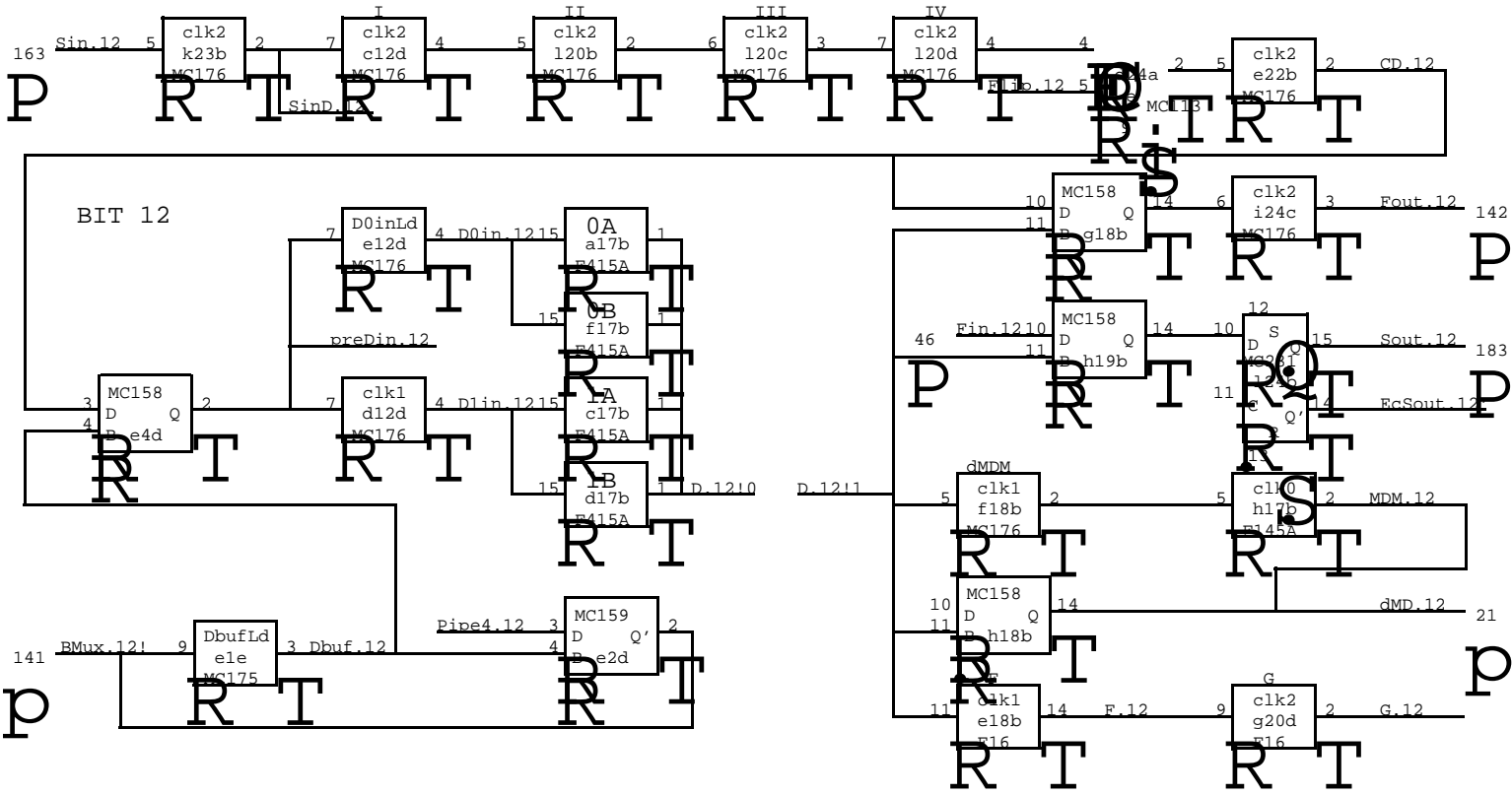

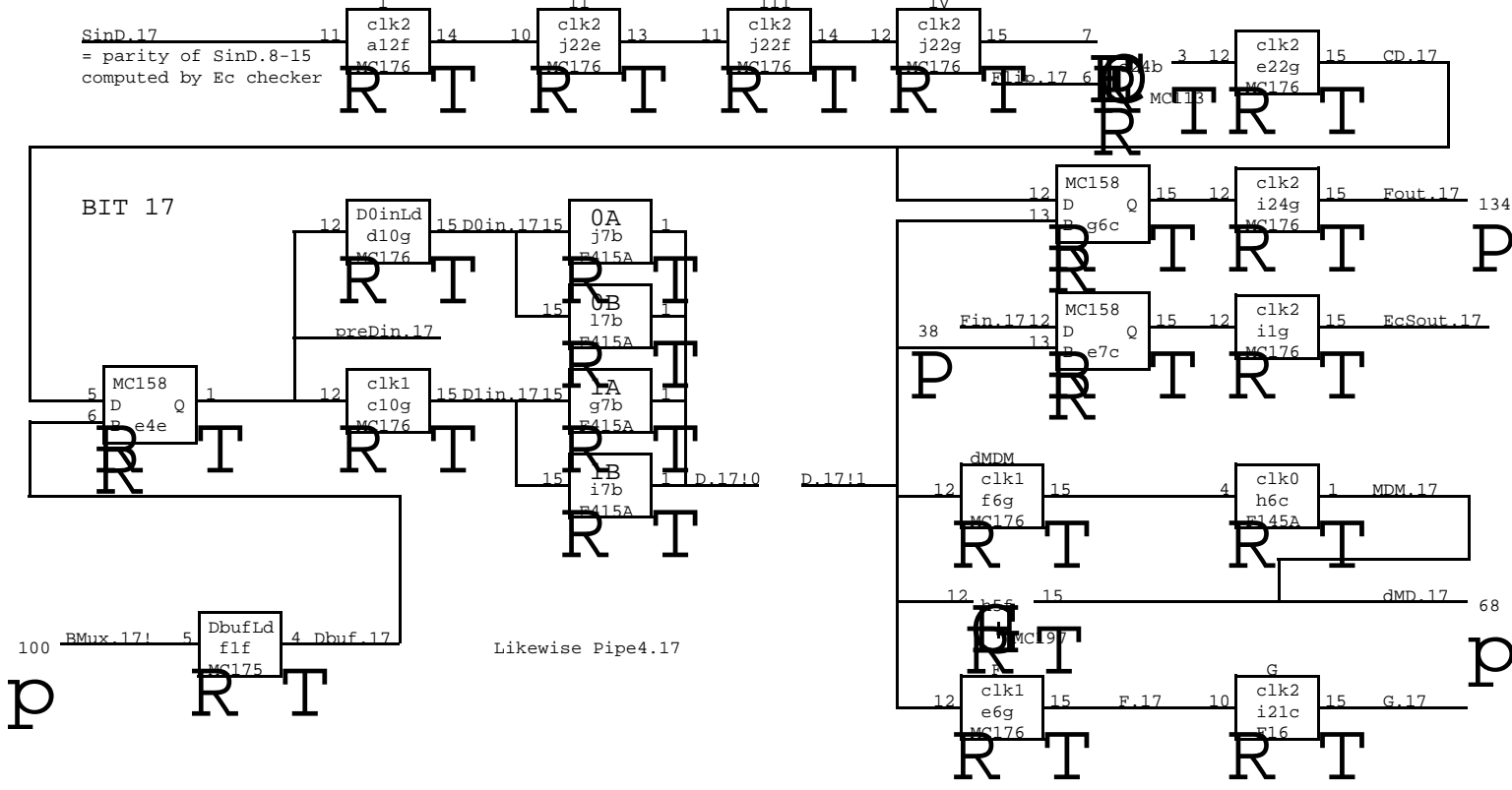
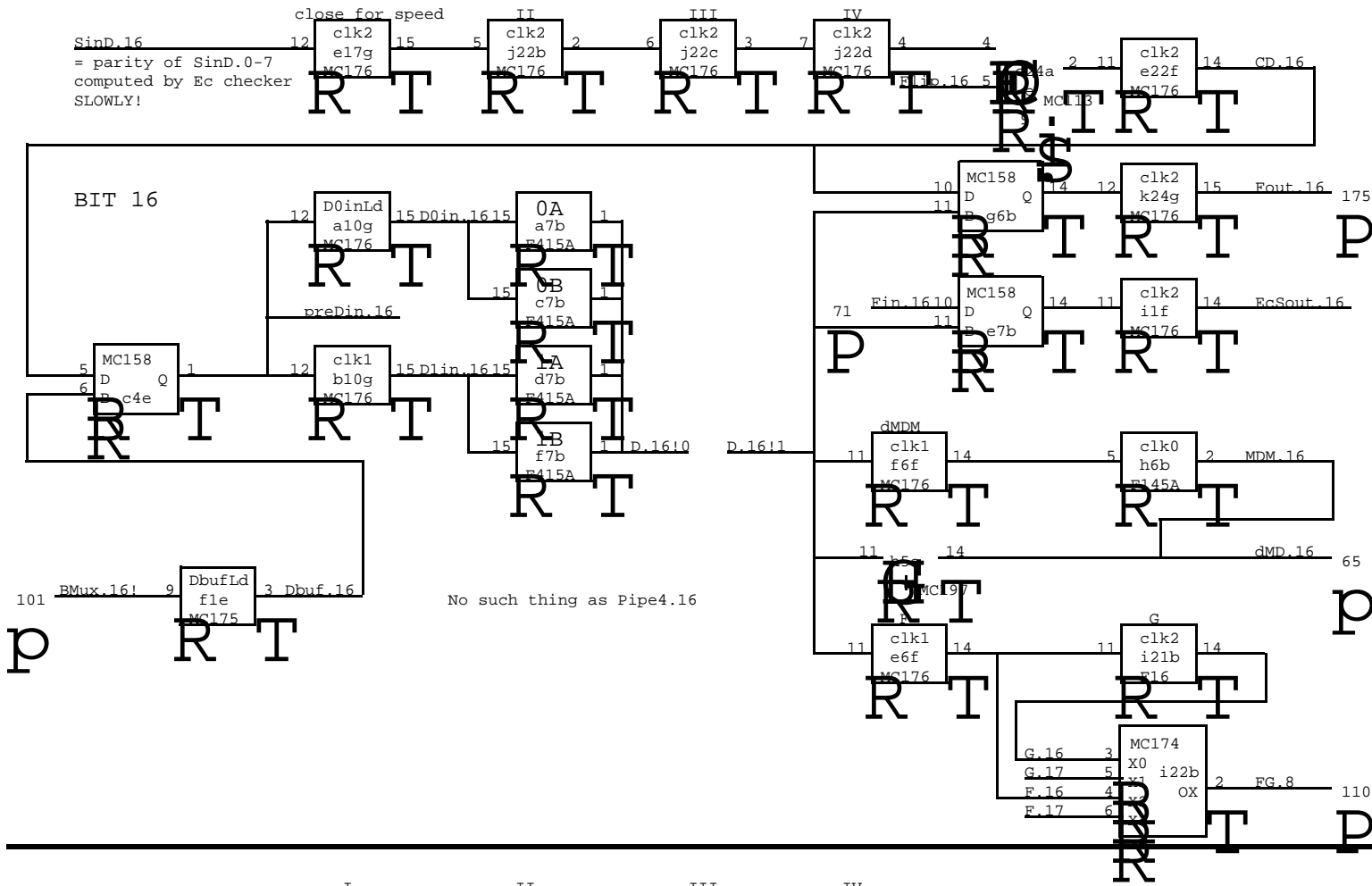

XEROX PARC/CSL	Project Dorado	Memory data board Bit slices 16-17	File MemD15.sil	Designer D. Clark	Rev Da	Date 7/10/79	Page 15
-------------------	-------------------	---------------------------------------	--------------------	----------------------	-----------	-----------------	------------

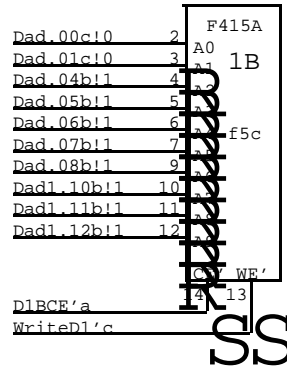
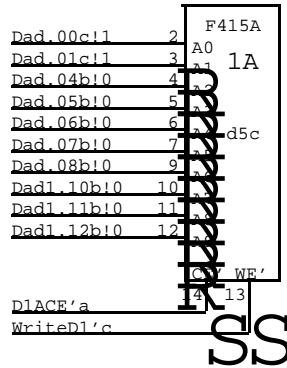
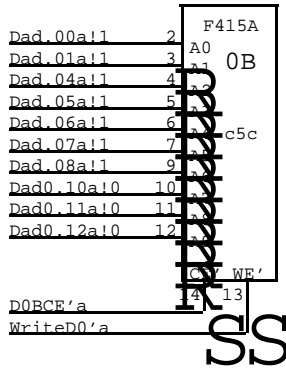
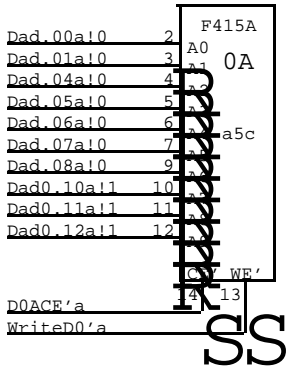

BIT 01

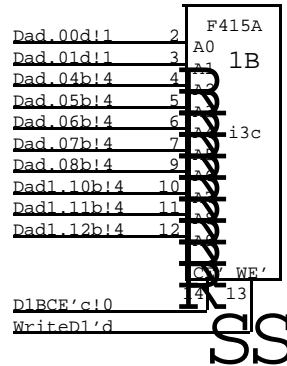
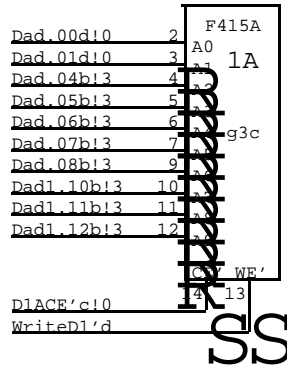
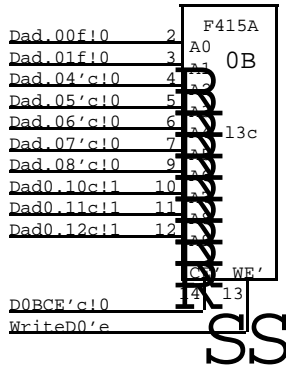
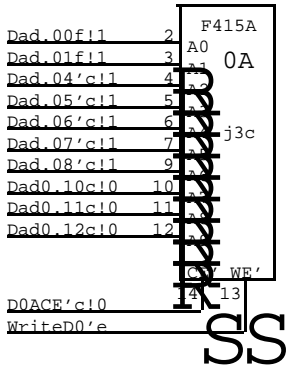

BIT 02

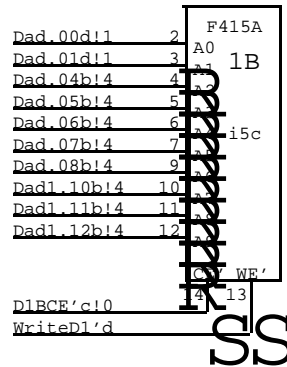
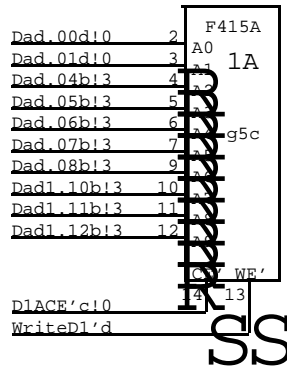
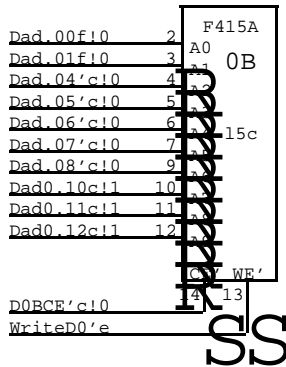
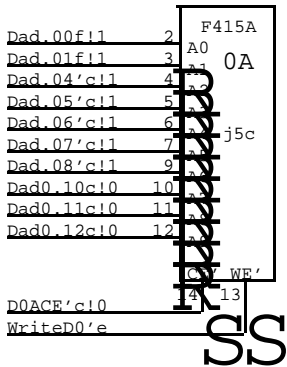

BIT 03

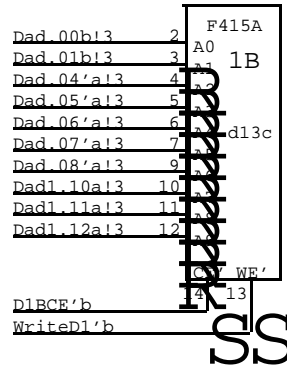
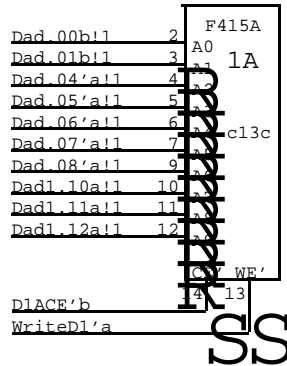
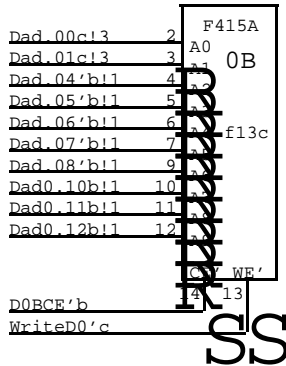
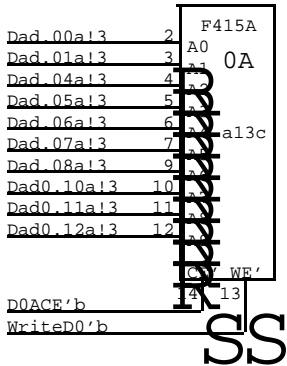

BIT 04

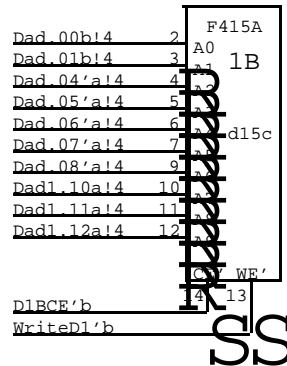
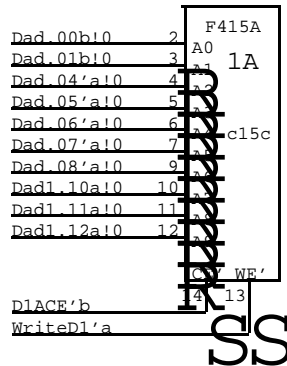
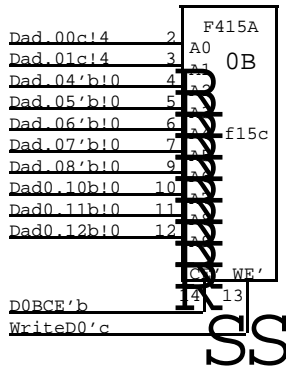
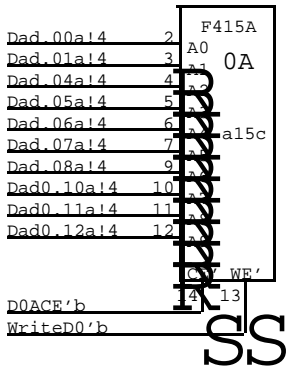

BIT 05

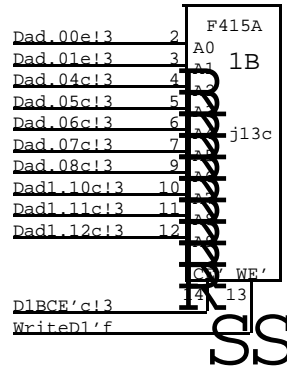
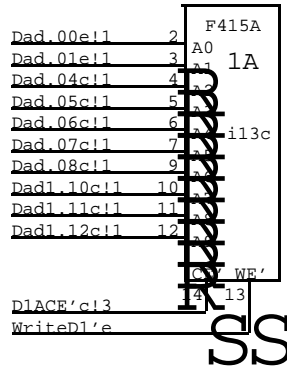
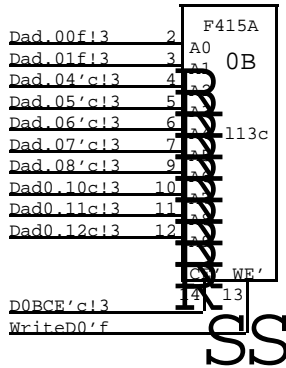
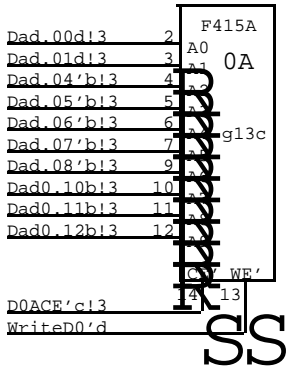

BIT 06

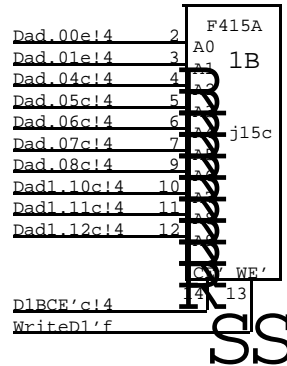
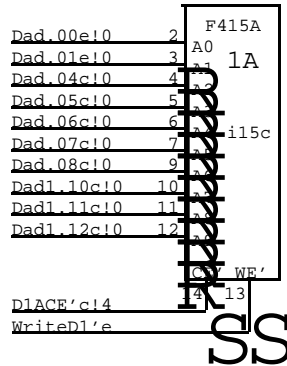
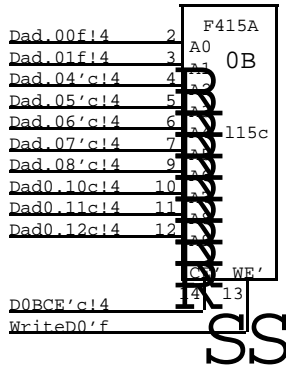
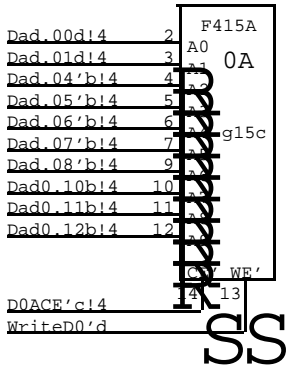

BIT 07

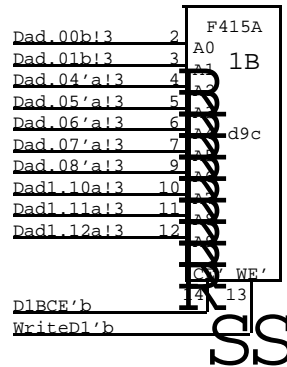
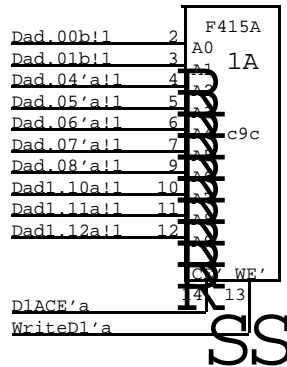
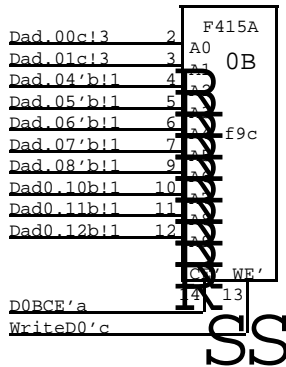
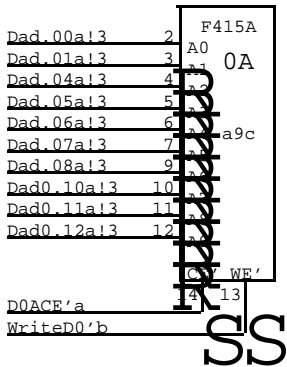

BIT 08

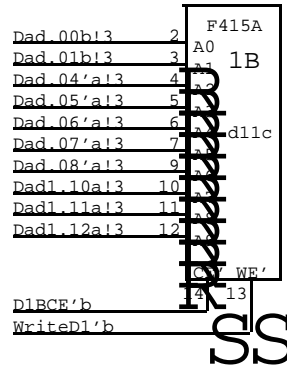
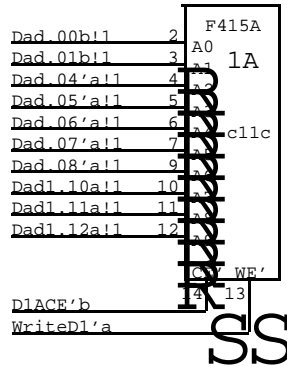
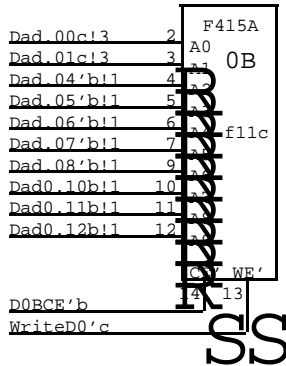
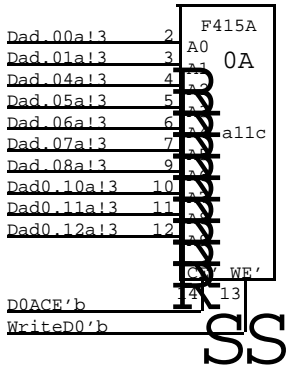

BIT 09

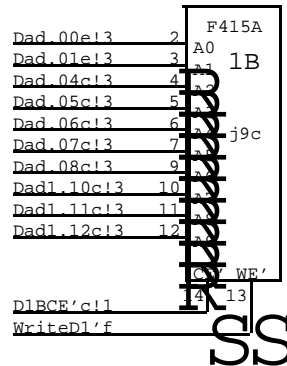
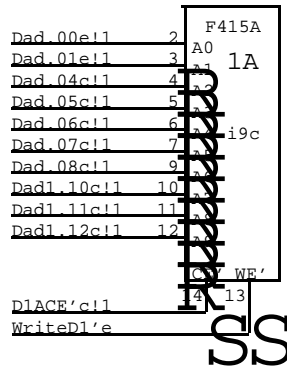
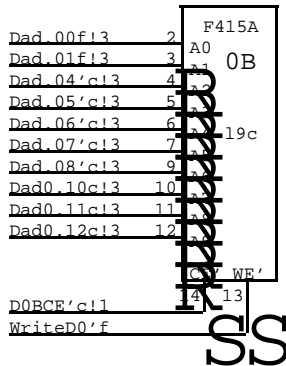
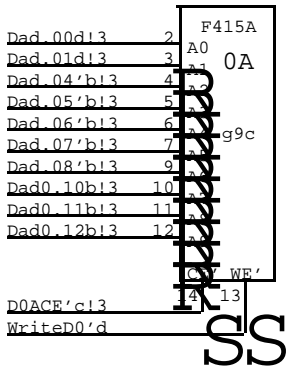

BIT 10

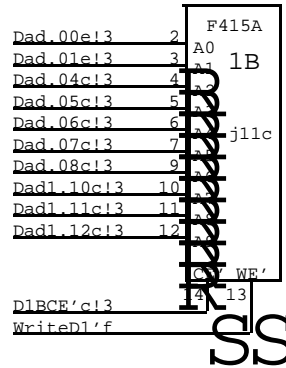
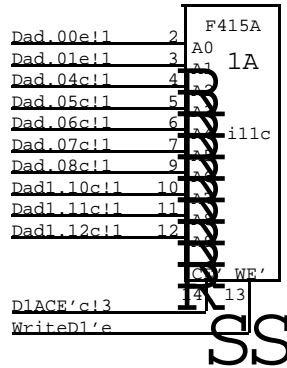
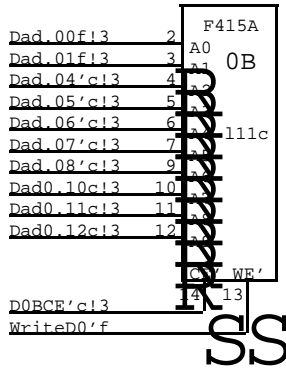
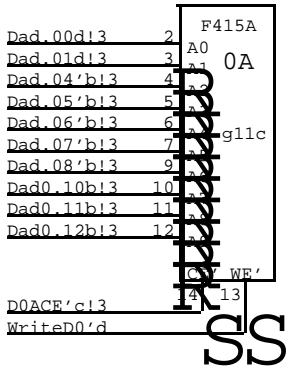

BIT 11

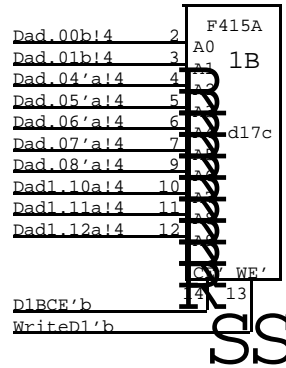
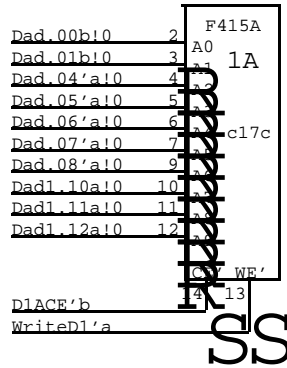
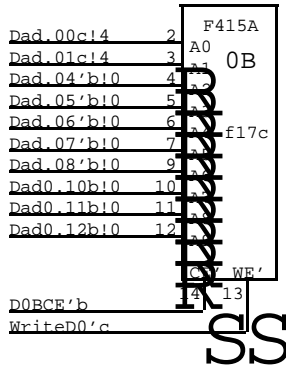
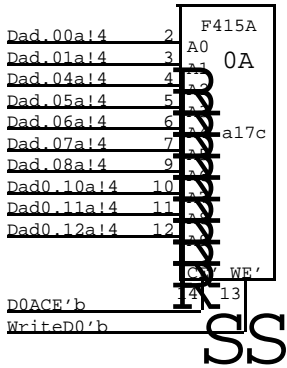

BIT 12

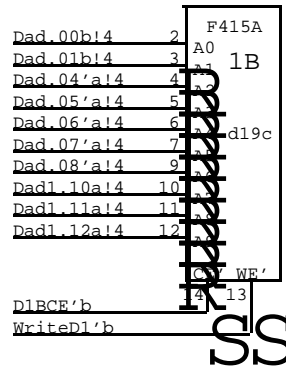
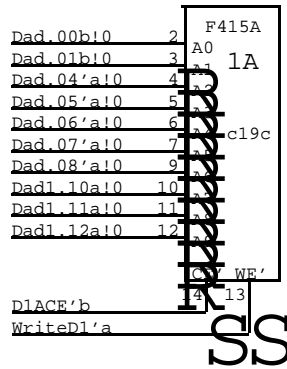
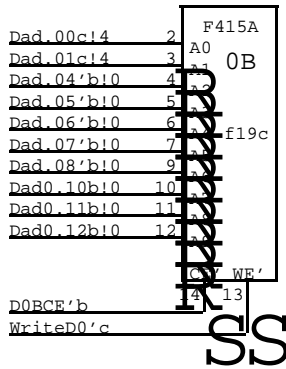
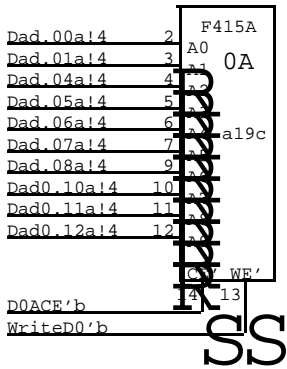

BIT 13

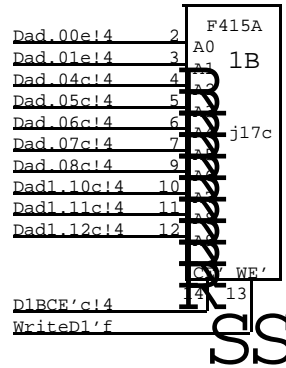
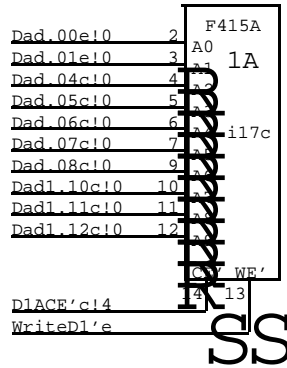
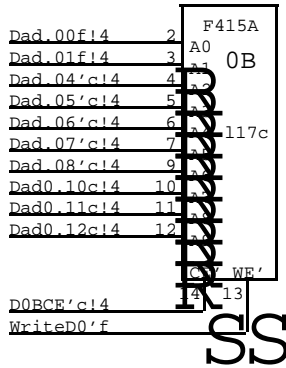
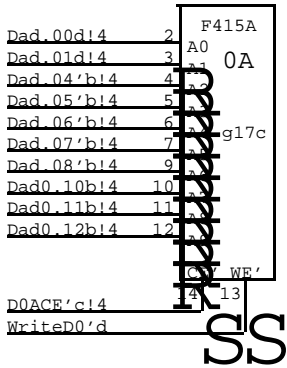

BIT 14

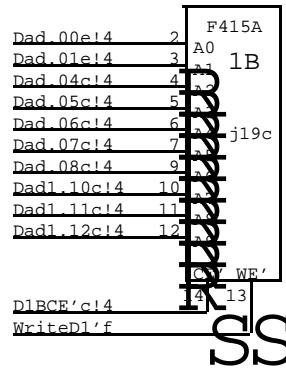
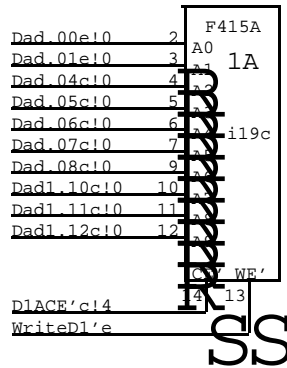
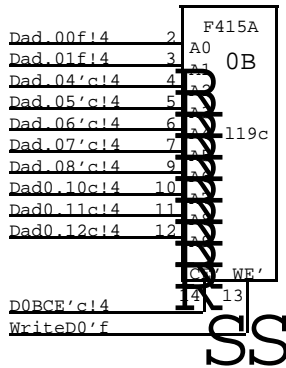
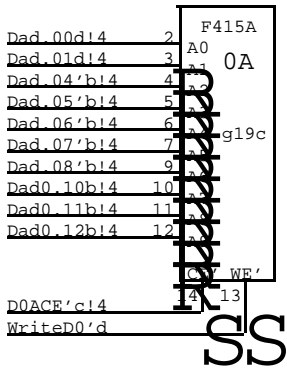

BIT 15

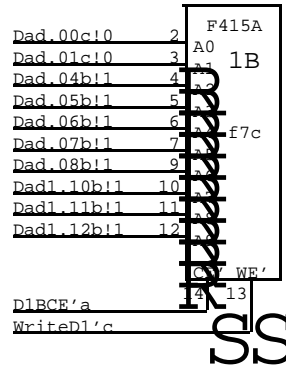
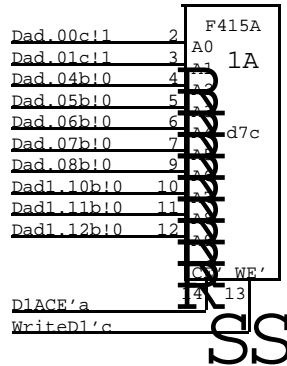
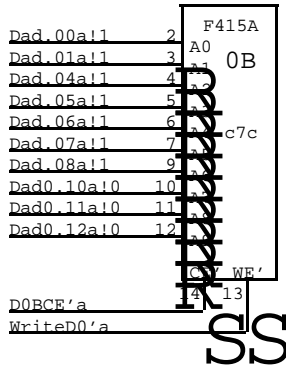
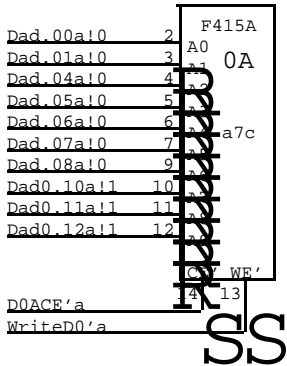

BIT 16

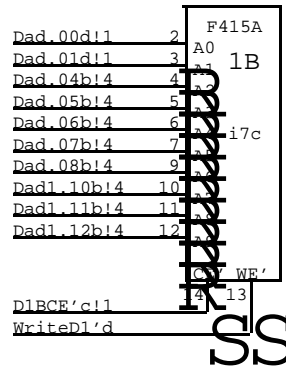
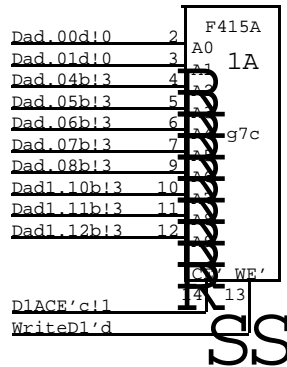
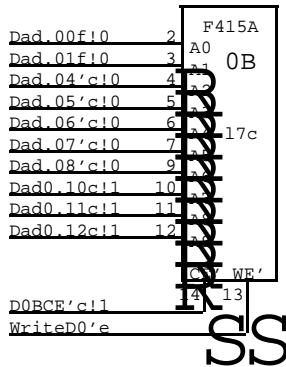
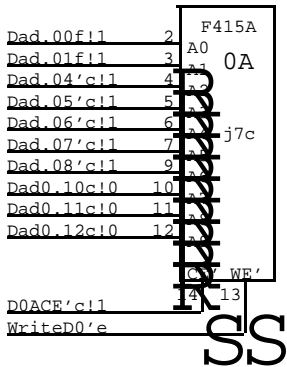

BIT 17

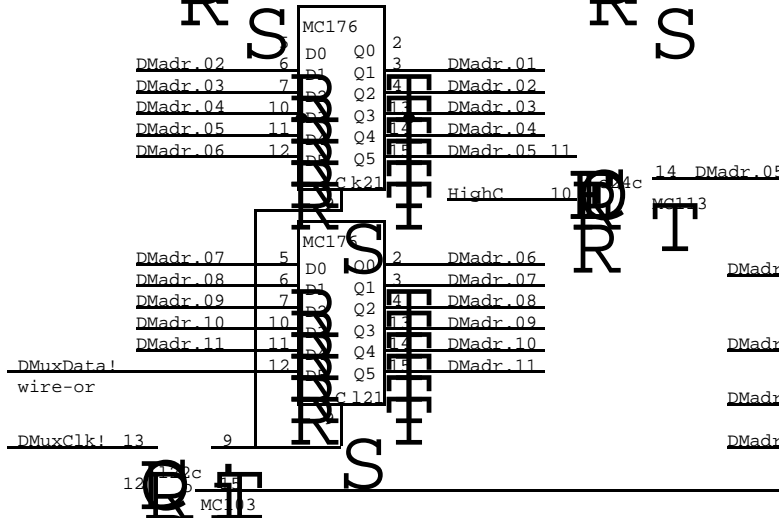
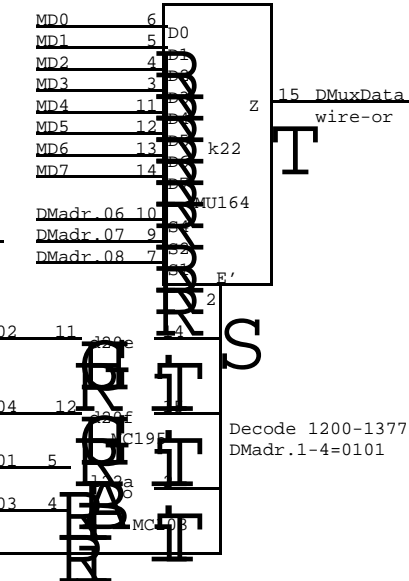
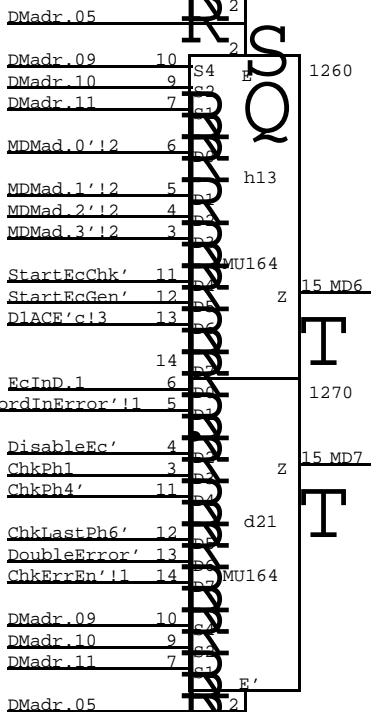
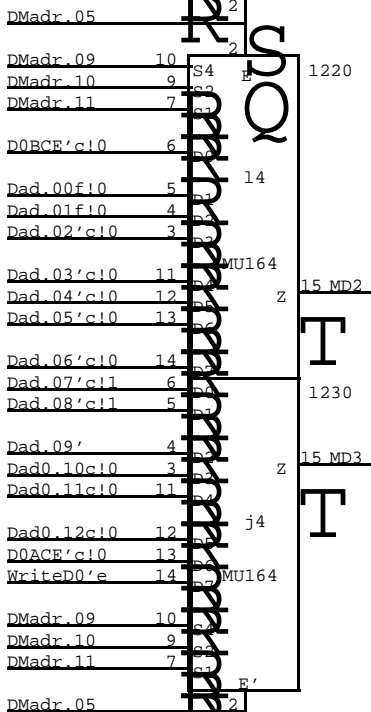
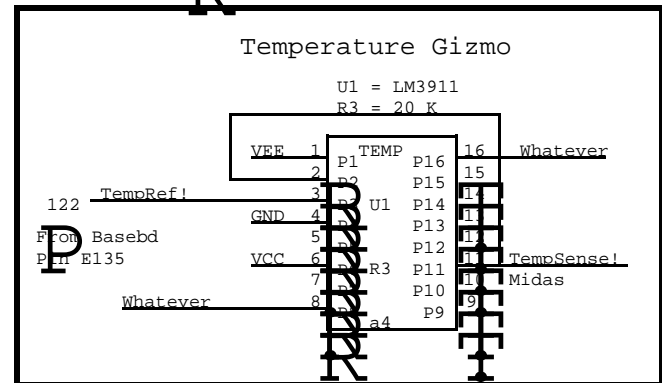
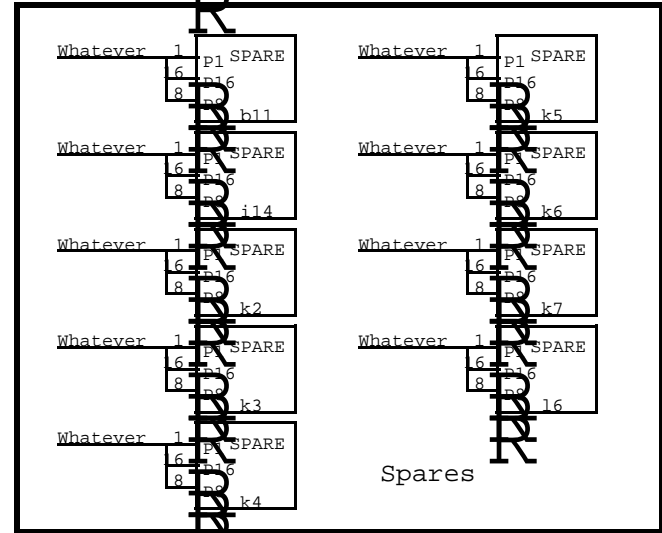
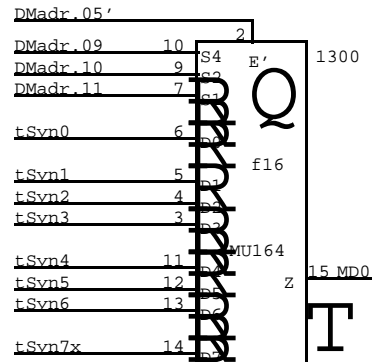
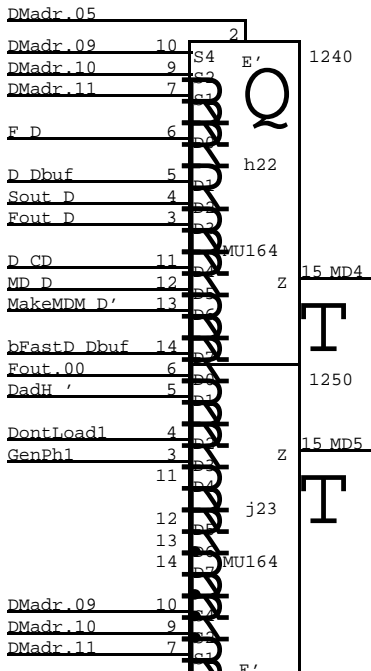
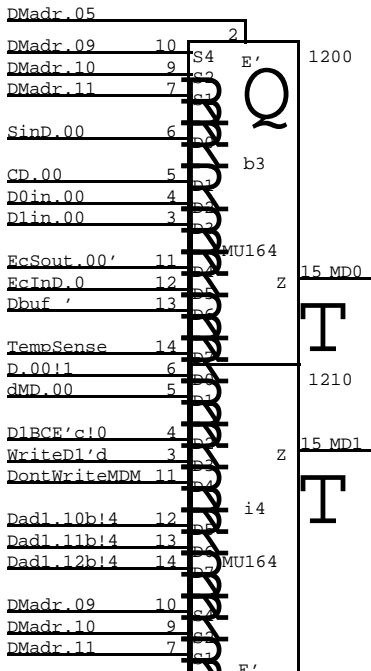

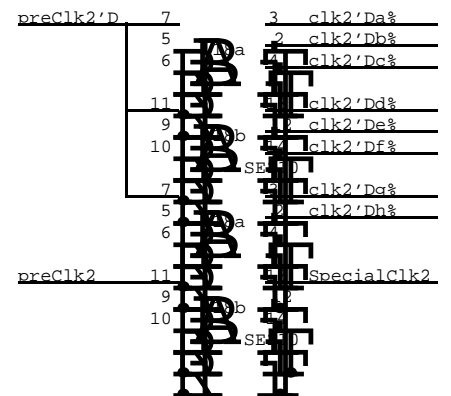
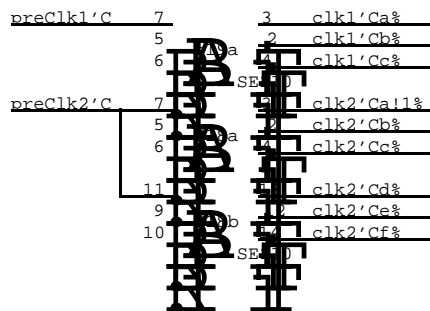
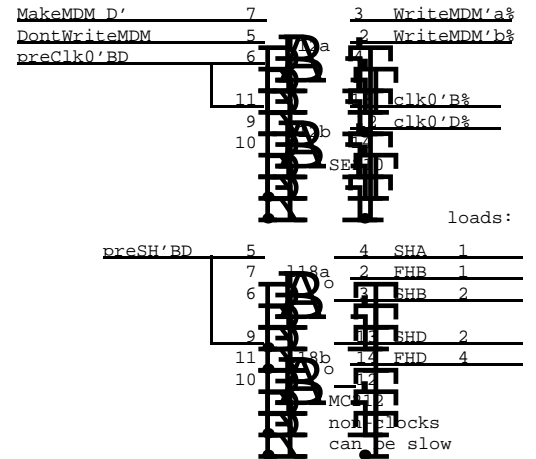
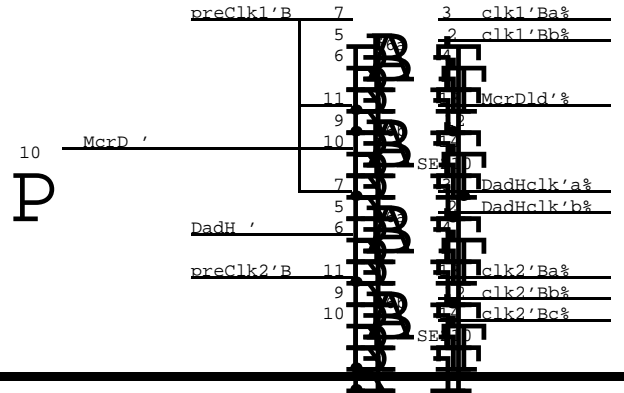
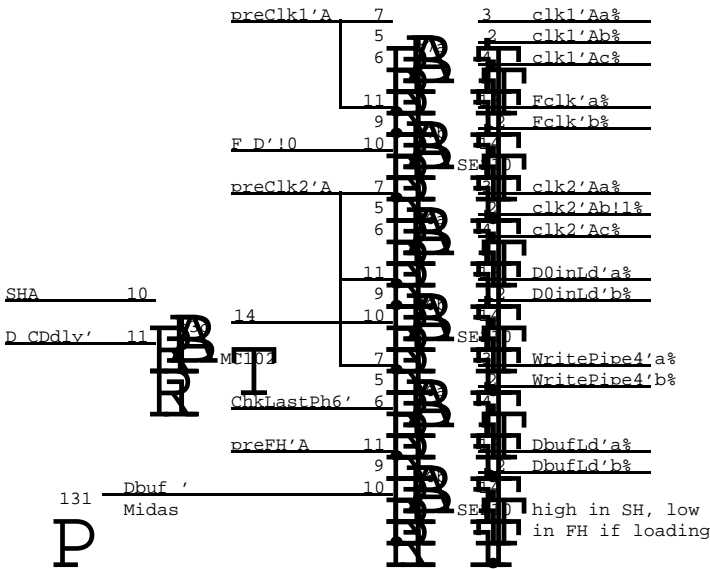
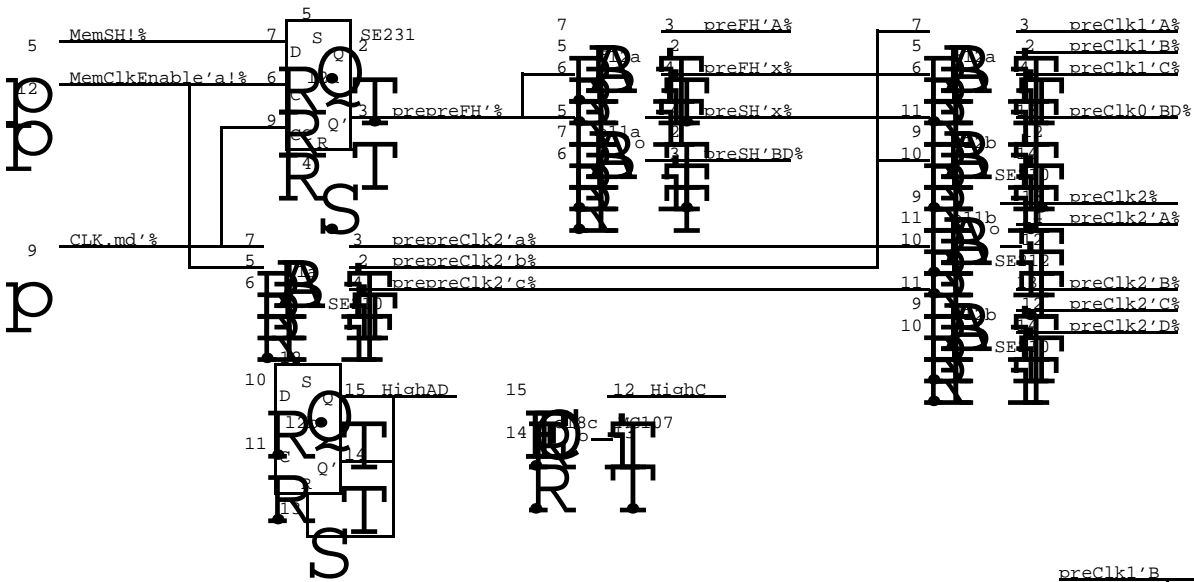

Cxxx	a 181	b 168	c 153	d 137	e 124	f 109	93 g	80 h	64 i	48 j	33 k	20 l	B
1	Sout drvr 0-1 231 2a	BMux rcvr 0,1,8,9 175 *a	BMux rcvr 2,3,10,11 175 *a	EcOut 0,2,4,6 dSTPerr 176 2a	BMux rcvr 4-6,12,13 175 *b	BMux rcvr 7,14-17 175 *b	Dad rcvrs 2,3 231 *a	rcvrs 6,7 231 *b	SinD.8-11 EcSt.16,17 176 2a	Sout drvr 10-11 231 2a	Sout drvr 8-9 231 2a	Clock 210	1
2	Sout drvr 2-3 231 2a	BMux drvr 0,1,8,9 159	SinD.0-3 EcInD.0 176 2a	BMux drvr 2,3,10,11 159	BMux drvr 4,5,12,13 159	BMux drvr 6,7,14,15 159	4,5 231 *a	8,9 231 *b	0-5 Test 176 *	Syn 6-8 176 *		231	2
3	DOA.00 a,a,a,a,a 415A	SinD.0 CD.0 DntIn.0 EcSout.0 EcInD.0	DOB.00 a,a,a,a,a 415A	D1A.00 c,b,b,a,c 415A	MemError ECFault PreDntInLd DriveBMux 102	D1B.00 c,b,b,a,c 415A	D1A.02 d,b,b,c,d 415A	Pipe34Ad DntWrtMDM 176 0	D1B.02 d,b,b,c,d 415A	DOA.02 f,'c,c,c,e 415A		DOB.02 f,'c,c,c,e 415A	3
4	TempSense Gizmo PIAT	0,1,8,9 158	2,3,4,16 158	preDin 6,10,11 158	5,7,12,17 158	13,14,15 158	dFout 0-3 158	MdM 0-3 145 *a	CE1B.D.0 10-12(11) Write(11) CEOA, DWRMDM GMD.0	Dad.7-9 10-12(0) Write0		Dad.0-6 CEOB MUI64	4
5	DOA.01 a,a,a,a,a 415A	12-15 145	DOB.01 a,a,a,a,a 415A	D1A.01 c,b,b,a,c 415A	dSout 0-3 158	D1B.01 c,b,b,a,c 415A	D1A.03 d,b,b,c,d 415A	dMd 0-3,16,17 197	D1B.03 d,b,b,c,d 415A	DOA.03 f,'c,c,c,e 415A		DOB.03 f,'c,c,c,e 415A	5
6	4-7 Pipe4 145	8-11 145	clks 210	clks 210	F 0-3,16,17 176 *a	dMdM 0-3,16,17 176 1a	dFout 16,17 158	MdM 16,17 145 *a	clks 210	clks 210			6
7	DOA.16 a,a,a,a,a 415A	clks 210	DOB.16 a,a,a,a,a 415A	D1A.16 c,b,b,a,c 415A	dSout 16,17 158	D1B.16 c,b,b,a,c 415A	D1A.17 d,b,b,c,d 415A	Dad1 10-12 b F16 1a	D1B.17 d,b,b,c,d 415A	DOA.17 f,'c,c,c,e 415A		DOB.17 f,'c,c,c,e 415A	7
8	Dad0 10-12 a F16 2b	Dad.2-5 a, 'a 101	Dad.6-8 a, 'a F_D' 101	Dad.0-1 a,b,c 210	Writes a,b,c 211	Dad.2-5 b, 'b 101	Dad.6-8 b, 'b b_Pipe4' 101	Writes d,e,f 210	Dad.0-1 d,e,f 210	Dad.2-5 c, 'c 101	Dad.6-8 c, 'c Dad.13' 101	Dad0 13 10-12 c F16 2b	8
9	DOA.08 a,a,a,a,b 415A	Dad1 10-12 a F16 1b	D1A.08 b,'a,a,a,a 415A	D1B.08 b,'a,a,b,b 415A	Dad0 10-12 b F16 2b2	DOB.08 c,'b,b,a,c 415A	DOA.10 d,'b,b,c,d 415A	dSout 8-11 158	D1A.10 e,c,c,c,e 415A	D1B.10 e,c,c,c,f 415A	Dad1 10-12 c F16 1b	DOB.10 f,'c,c,c,f 415A	9
10	D0in0,1,4 8,9,16 176 *a	Dlin0,1,4 8,9,16 176 1b	Dlin2,3,6, 10,11,17 176 1b	D0in2,3,6, 10,11,17 176 *b	F 8-11 176 *b	dMdM 8-11 ClearWA 176 1a	dFout 8-11 158	dMd 8-11 158	CE's 0A, 1A 210	CE's 0B, 1B 210	preCE 159	preCE DntLoad0 1664	10
11	DOA.09 a,a,a,b,b 415A		D1A.09 b,'a,a,b,a 415A	D1B.09 b,'a,a,b,b 415A	preclks 212	DOB.09 c,'b,b,b,c 415A	DOA.11 d,'b,b,c,d 415A	MdM 8-11 145 *b	D1A.11 e,c,c,c,e 415A	D1B.11 e,c,c,c,f 415A	B 180	DOB.11 f,'c,c,c,f 415A	11
12	0-3,17 176 2c	Ec pipe 4-9 176 2c	I10-15 176 2c	Dlin5,7,12, 13,14,15 176 1c	D0in5,7,12, 13,14,15 176 *b	preclks 210	preclks 210	MDMad 141 2c	WriteMDM clk0'B,D 210		Generator A 180	163	12
13	DOA.04 a,a,a,b,b 415A	Cphi 172	D1A.04 b,'a,a,b,a 415A	D1B.04 b,'a,a,b,b 415A	ChkPhi F00 2a0	DOB.04 c,'b,b,b,c 415A	DOA.06 d,'b,b,c,d 415A	MDMad(4) CE1A StrtEcChk StrtEcGen	D1A.06 e,c,c,c,e 415A	D1B.06 e,c,c,c,f 415A		DOB.06 f,'c,c,c,f 415A	13
14	0-7 163	8-15 163	SinD.17 170	ChkQWi Chkwi F16 2a0	F 4-7 F16 1a	dMDM.4-7 LastQWi 176 1a	dFout 4-7 158	dMd 4-7 158		C 180	D 180	E 180	14
15	DOA.05 a,a,a,b,b 415A	A 180	D1A.05 b,'a,a,b,a 415A	D1B.05 b,'a,a,b,b 415A	dSout 4-7 158	DOB.05 c,'b,b,b,c 415A	DOA.07 d,'b,b,c,d 415A	MdM 4-7 145 *b	D1A.07 e,c,c,c,e 415A	D1B.07 e,c,c,c,f 415A	F 180	DOB.07 f,'c,c,c,f 415A	15
16	B 180	Checker C 180	D 180	A-C 158	D-E 158	tSyni MUI64	PipeII- 0,1 176 2c	IV/Gen 3 dClearWA 104	PipeII- 2,3 176 2c	IVb D_Cddly 231 2b	A-C 158	(E) 231 2a	16
17	DOA.12 a,a,a,b,b 415A	E 180	D1A.12 b,'a,a,b,a 415A	D1B.12 b,'a,a,b,b 415A	ChkPh,etc SinD.16dly 176 2a2	DOB.12 c,'b,b,b,c 415A	DOA.14 d,'b,b,c,d 415A	MdM 12-15 145 *b	D1A.14 e,c,c,c,e 415A	D1B.14 e,c,c,c,f 415A	D-E 158	DOB.14 f,'c,c,c,f 415A	17
18	tSyn0-3 F00 2b	tSyn4,7 231 2b	SinD.16 D_CD' HighC 107	clks 210	F 12-15 F16 1b	dMDM 12-15 TickTockCE ChkLstPh6 176 1b	dFout 12-15 158	dMd 12-15 158	clks 210	clks 210	GenPhi F00 2a	FH, SH 212	18
19	DOA.13 a,a,a,b,b 415A	tSyn5,6 231 2b	D1A.13 b,'a,a,b,a 415A	D1B.13 b,'a,a,b,b 415A	clks 210	DOB.13 c,'b,b,b,c 415A	DOA.15 d,'b,b,c,d 415A	dSout 12-15 158	D1A.15 e,c,c,c,e 415A	D1B.15 e,c,c,c,f 415A	PipeII- 8,9 176 2b	DOB.15 f,'c,c,c,f 415A	19
20	Syni F16 2c	Corrector WordInError F00 2c	WordInError F00 2c	WordInError F00 2c	CD 0-5 176 2e	G 2,3,10,11 F16 2e	G 4,5,12,13 F16 2a	G 6,7,14,15 F16 2a	PipeII- 4,5 176 2a	PipeII- 6,7 176 2h	PipeII- 10,11 176 2h	PipeII- 12,13 176 2h	20
21	DblError 170	Error ChkErrEn' 109	Syn3 D_Dbufdly 231 2c	EcCheck stuff MUI64	6-11 176 2e	FG 2,3 174	FG 4,5 174	FG 6,7 174	G 16,17 F16 2a	PipeII- 14,15 176 2e	IV 1-5 176	Midas 6-11 176	21
22	Flips16,17 ChkErrEn' 102	Flips0-7 162	Flips8-15 162	dCD 0-3 113	12-17 176 2f	G 0,1,8,9 F16 2f	preWrite 231 *	X_Ys MUI64	FG 8 174	PipeII- 16,17 176 2e	MuxData 164	Midas 2 Bank0CE 103	22
23	4-7 F16 1c	dPipe4 8-11 F16 1c	12-15 F16 1c	4-7 113	8-11 113	FG 0,1 174	dMD.D DntLoad1 dd_Dly 106	preWrite bTransport 102	DadH_ 231 0	Fout.0 DntLdl DadH' GenPh1	SinD.12-15 D_Cddlydly 176 2f	Sout drvr 14-15 231 2f	23
24	Sout drvr 6-7 231 2d	Sout drvr 4-5 231 2d	SinD.4-7 EcInD.1 ChkPh5w.o. 176 2d	12-15 113	16,17 DMadr.05' 113	EcOut 1,3,5,7 D_dly' 176 2f	MakeX rcvr 176 2d	bFastD.Dbf preWrite 1664	Fout drivers 11-15,17 176 2d	5-10 176 2e	0-4,16 176 2f	Sout drvr 12-13 231 2f	24

Cxxx a 11 b 26 c 39 d 55 e 70 f 86 99 g 114 h 129 i 143 j 159 k 174 l D

D chip code: Dad.0-1,2-8,10-12,CE,Write

PEROX PARC/CSL	Project Dorado	Reference Memory data board Layout	File MemD23.sil	Designer D. Clark	Rev Da	Date 7/09/79	Page 23
-------------------	-------------------	--	--------------------	----------------------	-----------	-----------------	------------