

ETHERPHONE BLOCK DIAGRAM

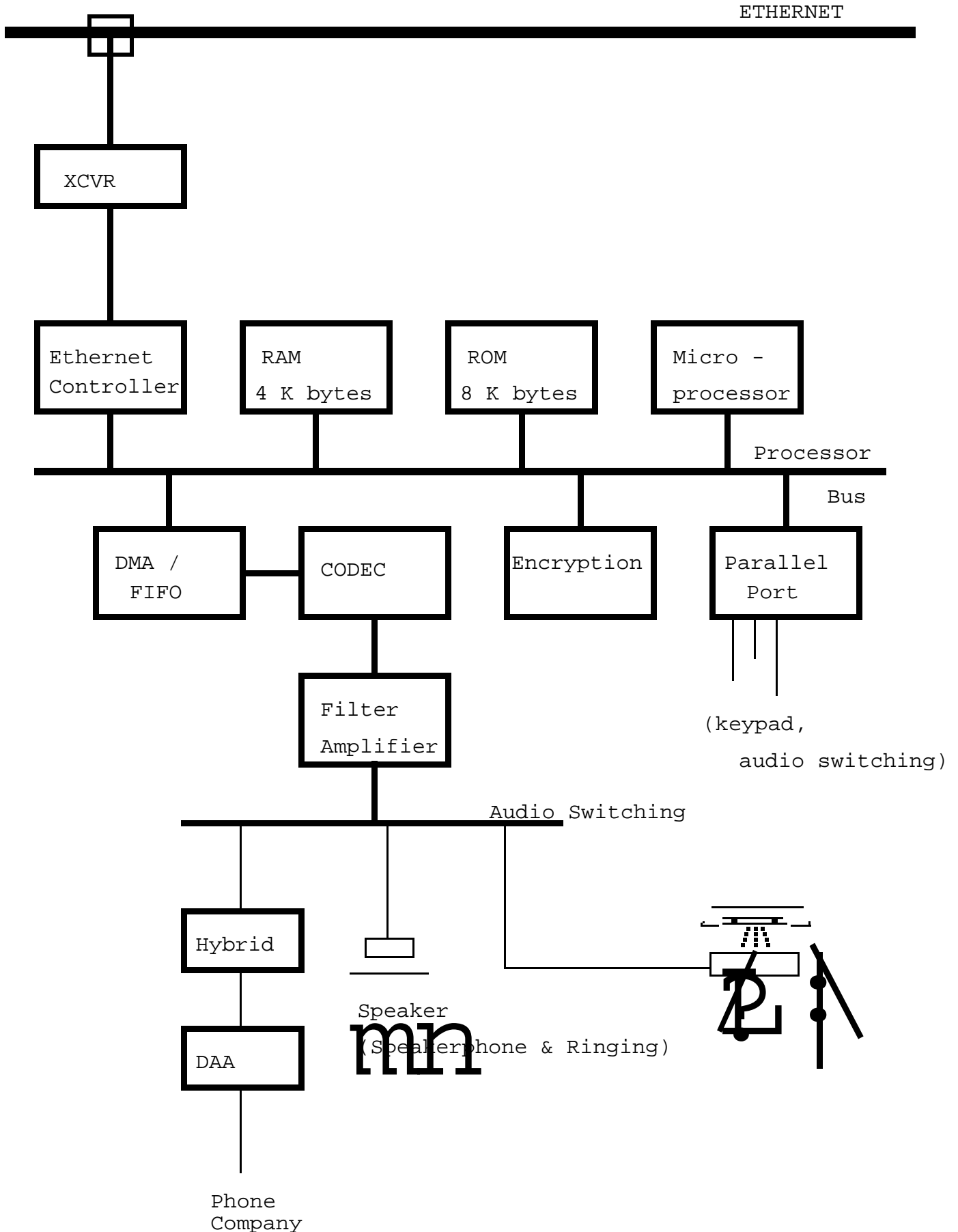

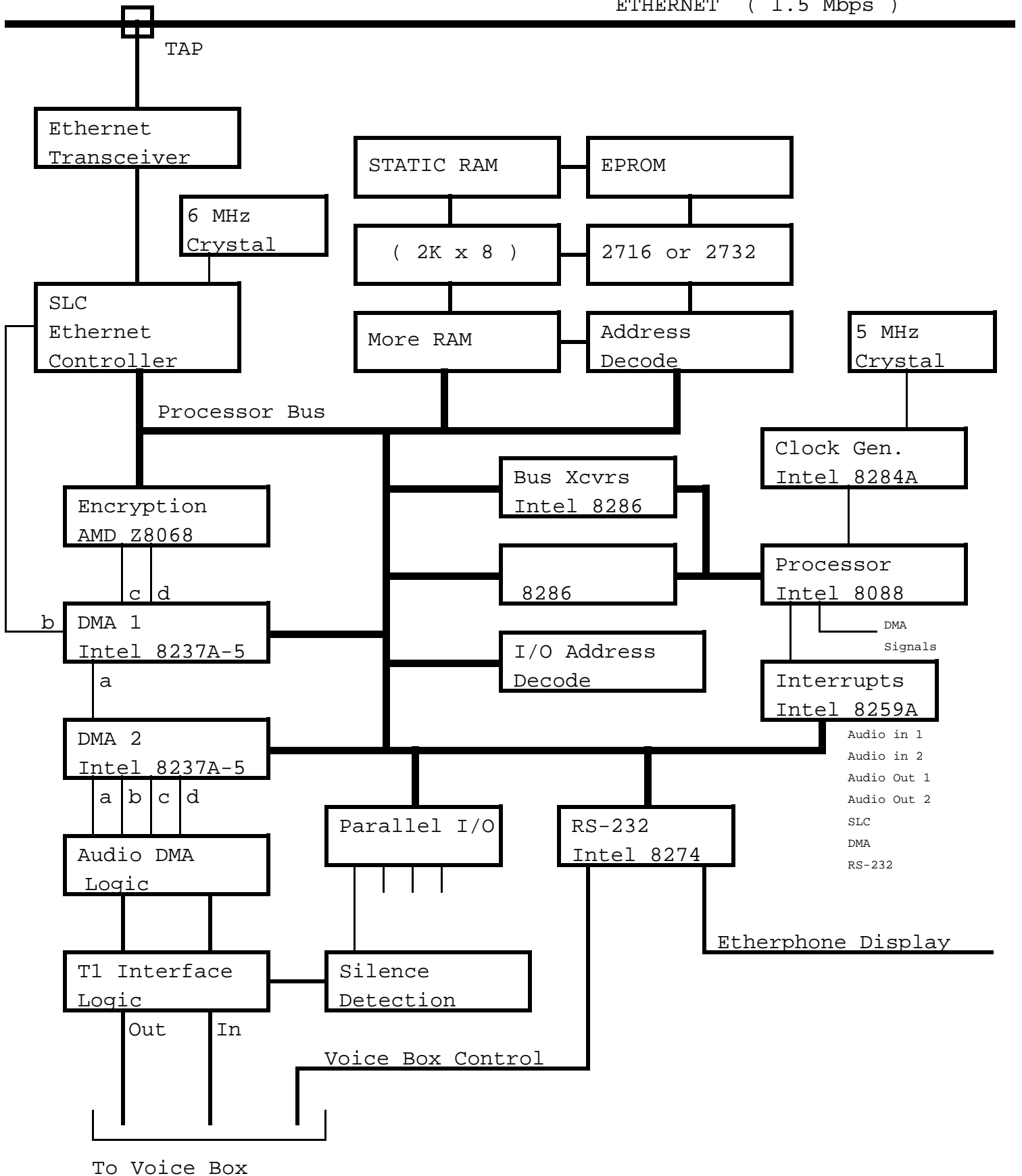

To Voice Box

Advanced Call Announcing Features

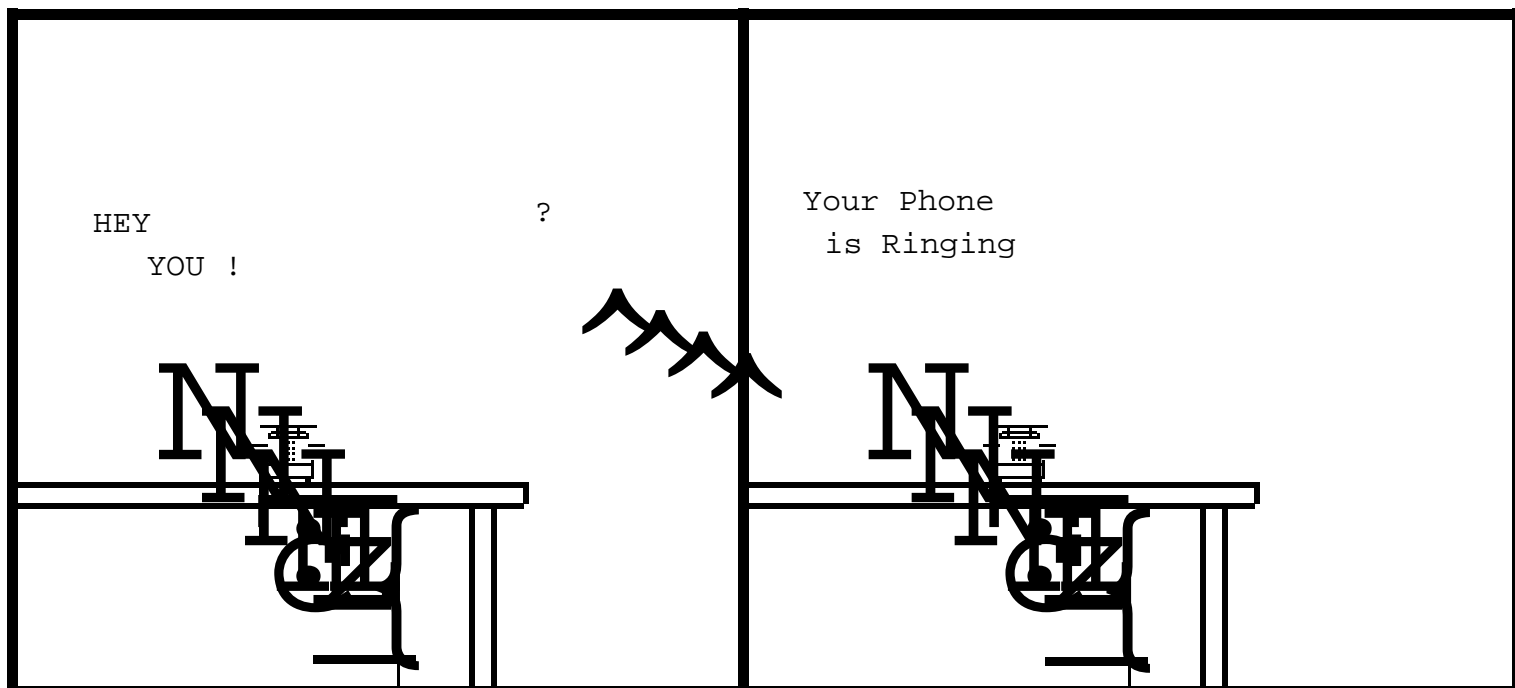

ADVANCED FILTERING FUNCTIONS

Ring !  
Ring !

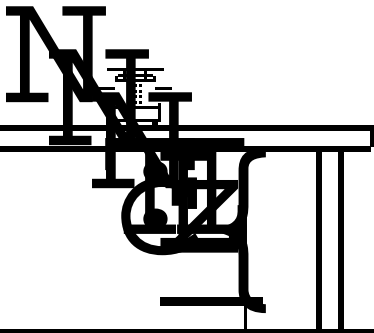

Hello?                      This is Fred.  
   Is Larry There?

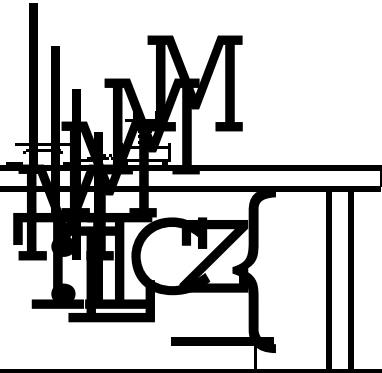

Larry doesn't  
want to  
talk to you.

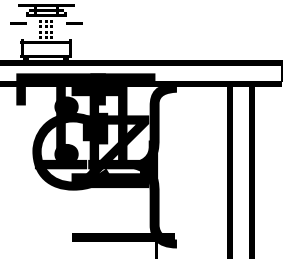
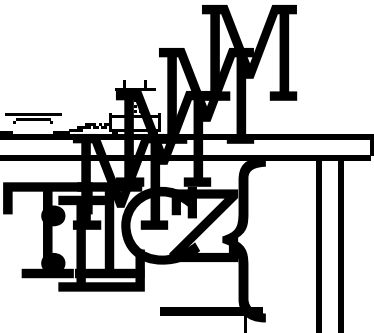

Intercom and reminder facilities

It's 1:15, time for dealer.  
Now a word from our sponsor:

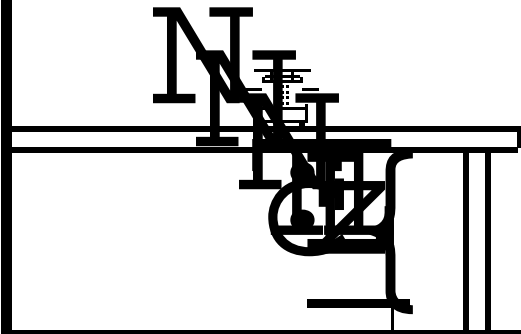

NEW! DWIM in Cedar!  
Use some TODAY!

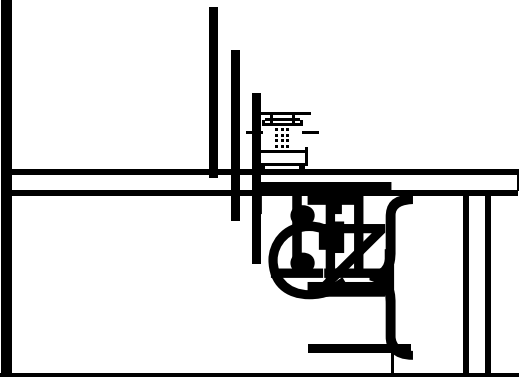

Ether Muzak

Drop kick me, Jesus  
Through the goal-posts of life

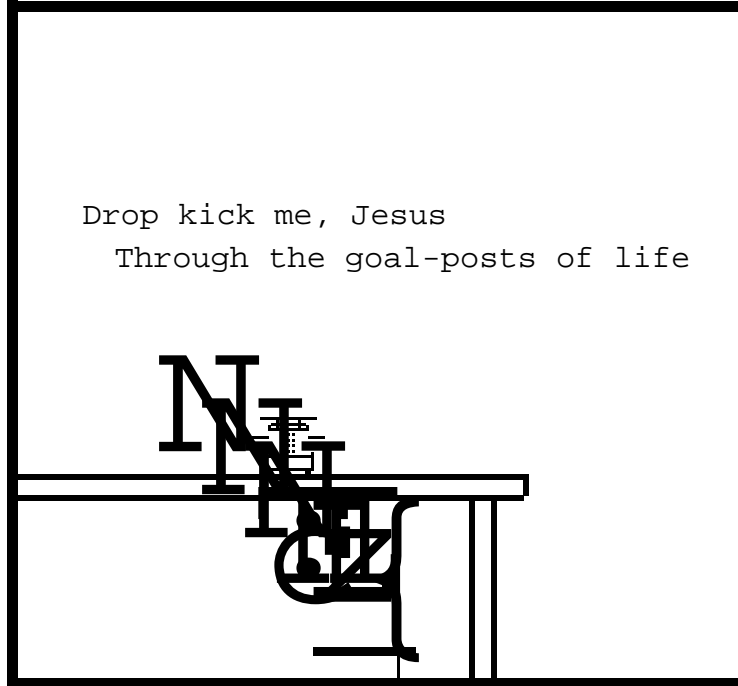

Advanced Call Forwarding

Forward my calls to Bob  
After one ring try  
Fred's office

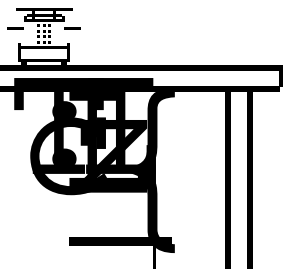
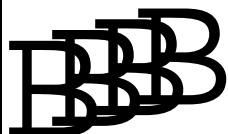

After two more rings, try  
the conference room.

If there's no answer, call  
me at home.

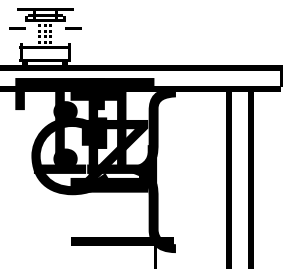
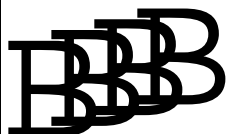

Sigh

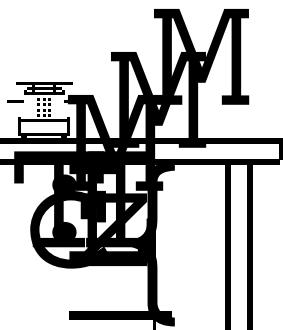

Except between 6 and 8

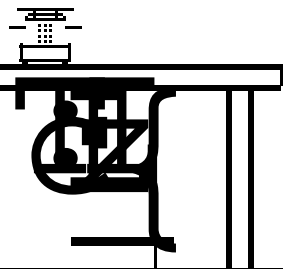
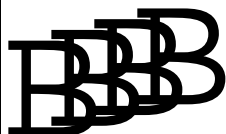

Call Filtering

Your wife is calling. . .

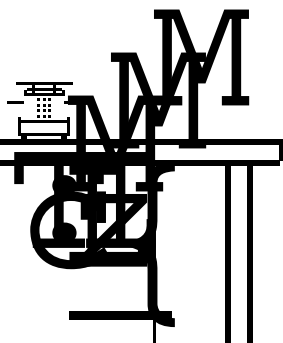

. . . Boy, is she mad. . .

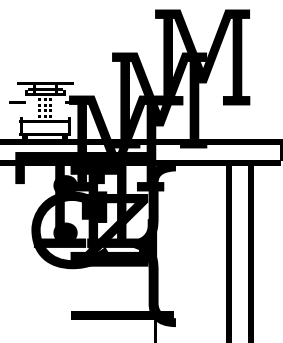

. . .It's understandable,  
considering the trouble  
she's had. . .

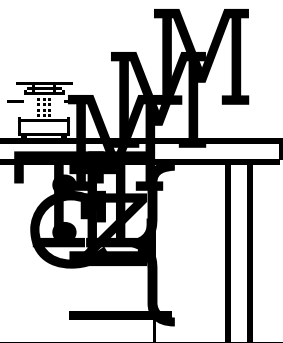

. . . getting through  
your filter.

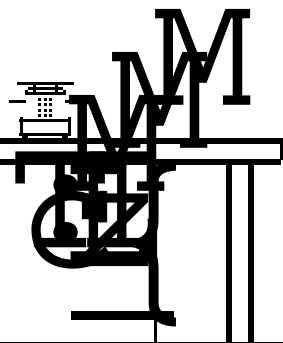



Automatic call placement

Is it really him?  
Or is it that damned  
phone of his?

BBB

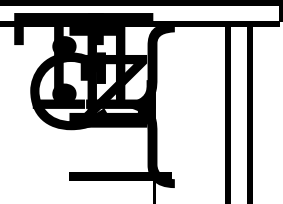

He SAYS its him.

NNM

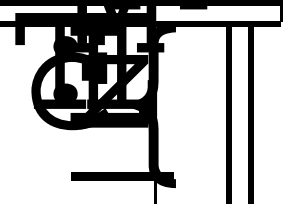

I've heard THAT before.

BBB

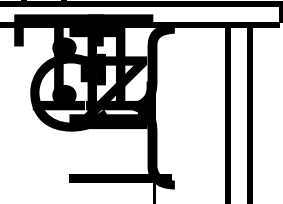

I'm sorry. Mr. Plotkin  
is out right now.

NNM

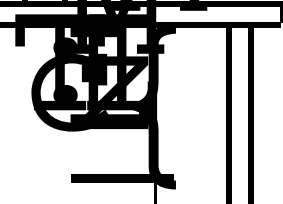

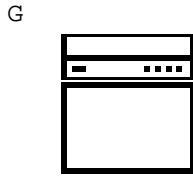
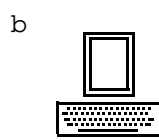
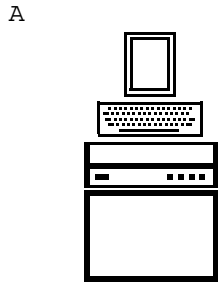
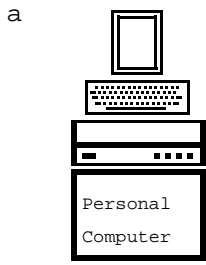

D

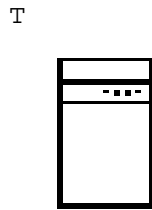
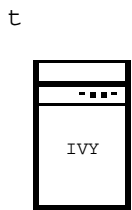
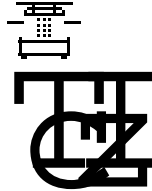

E

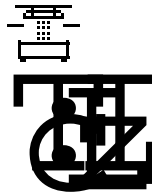

E



D



C

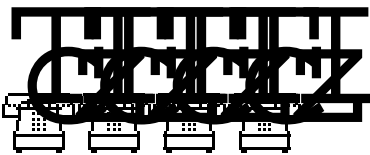

E  
T  
H  
E  
R  
N  
E  
T

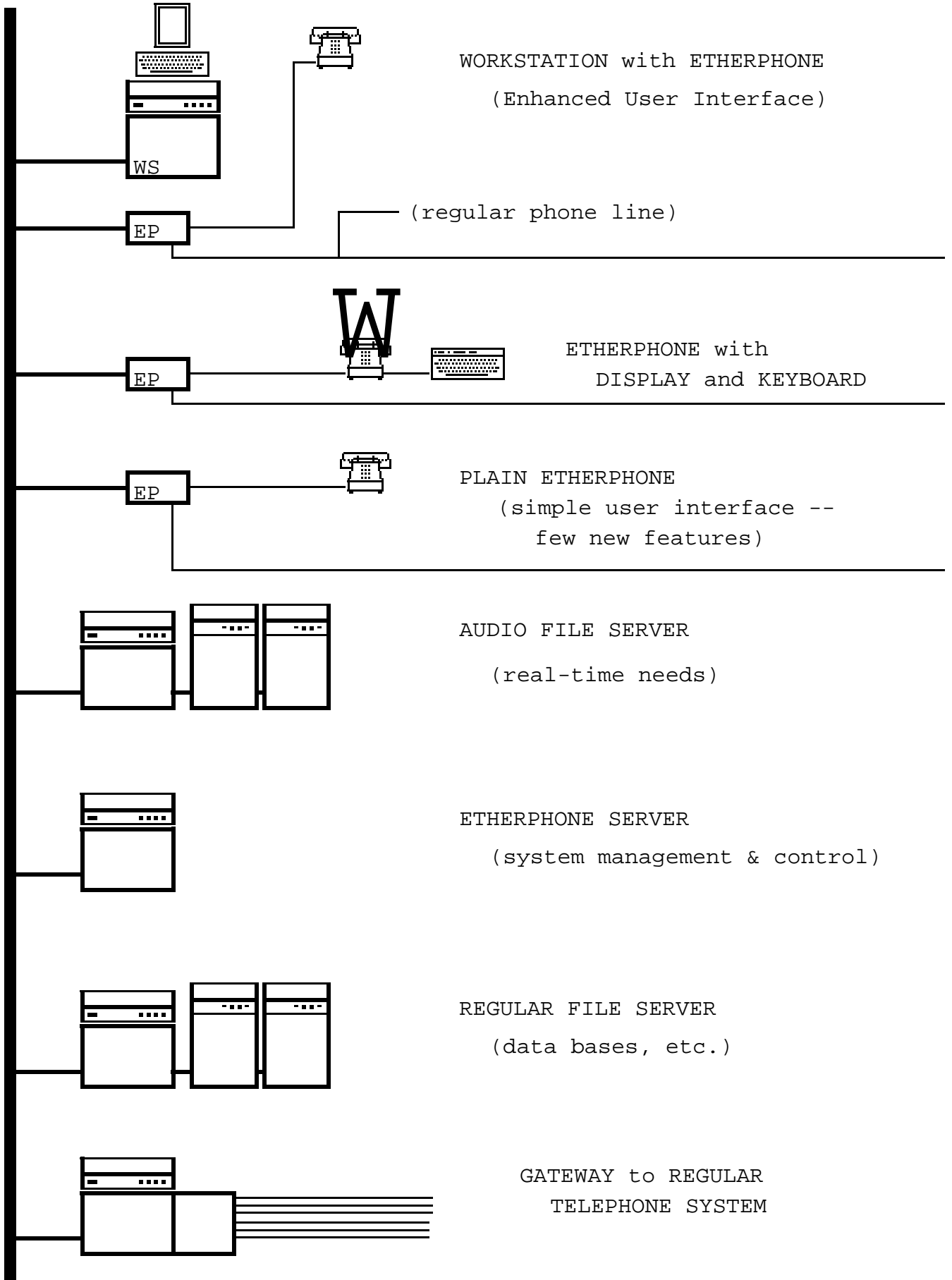

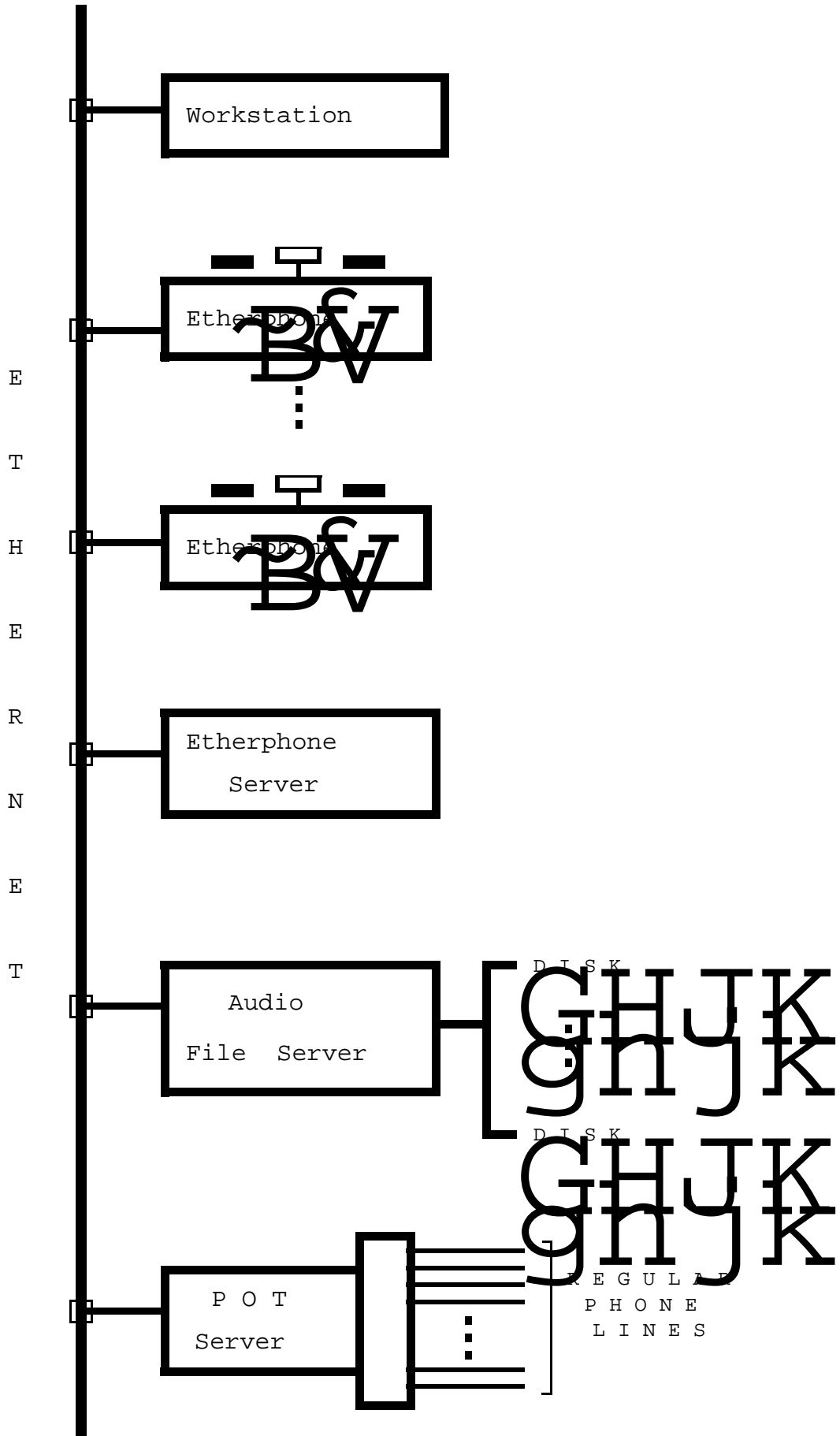

TO/FROM  
OTHER  
ETHERPHONE

### Etherphone

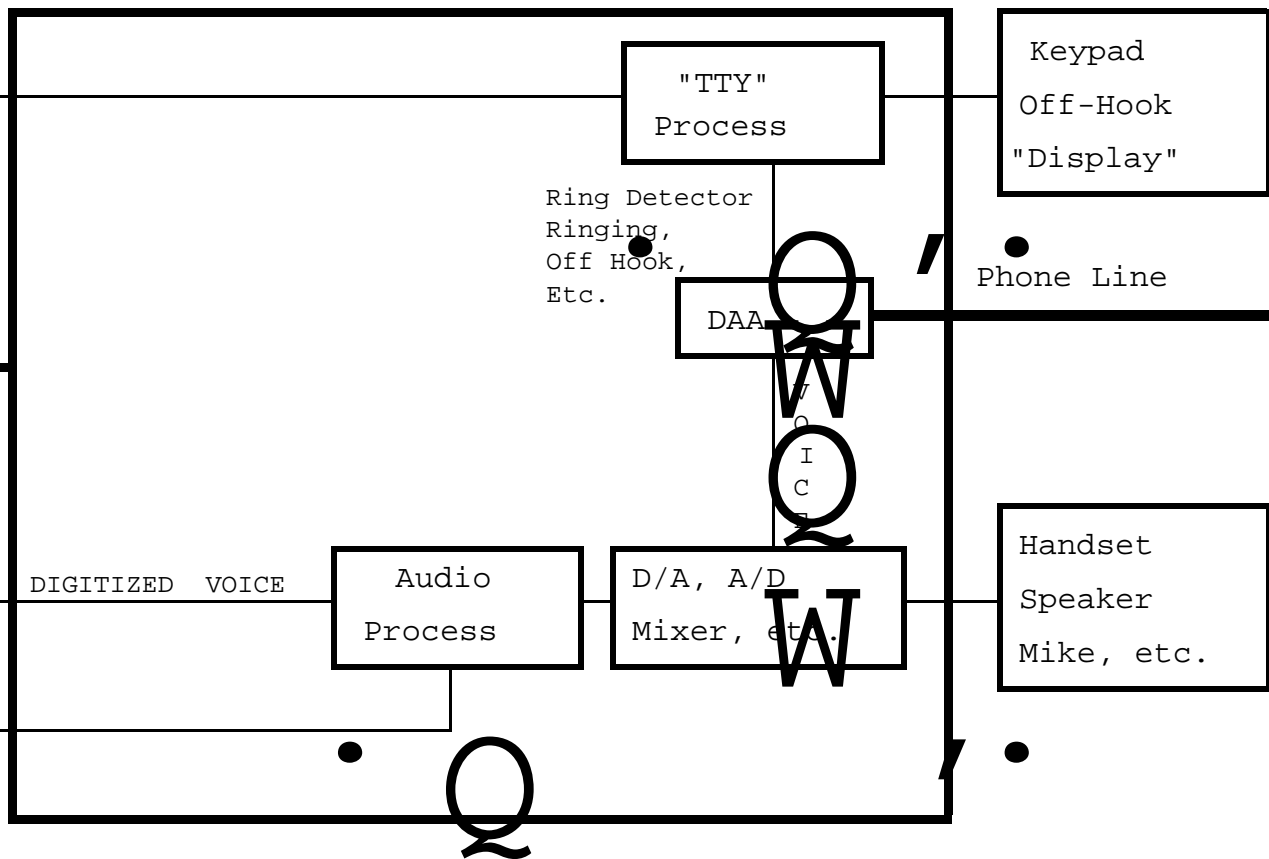

### Etherphone Server

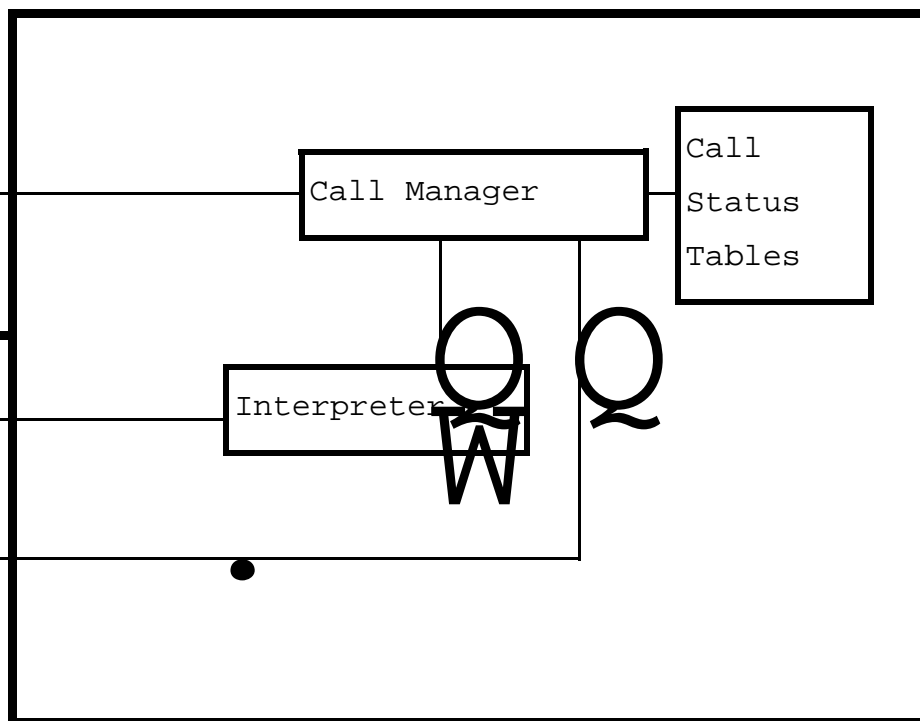

TO/FROM  
WORKSTATION

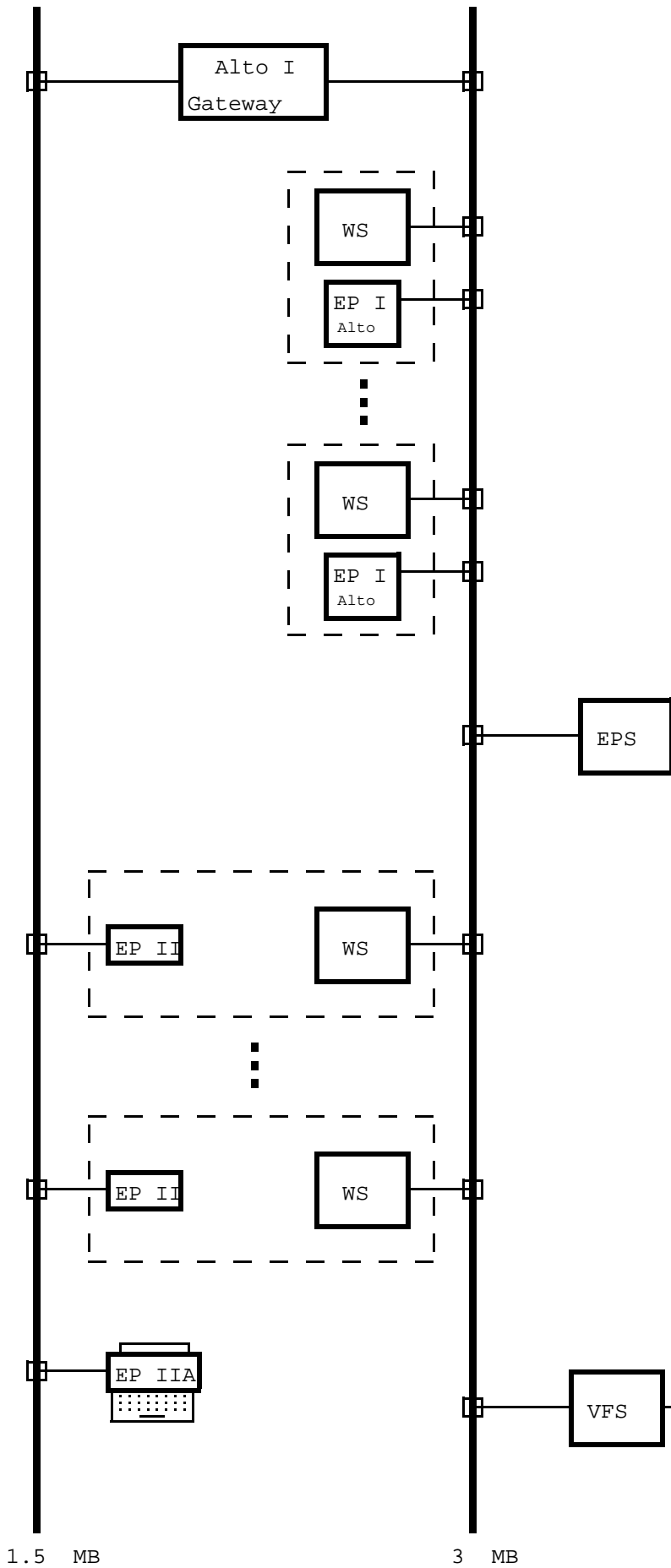

ASDF  
asdf

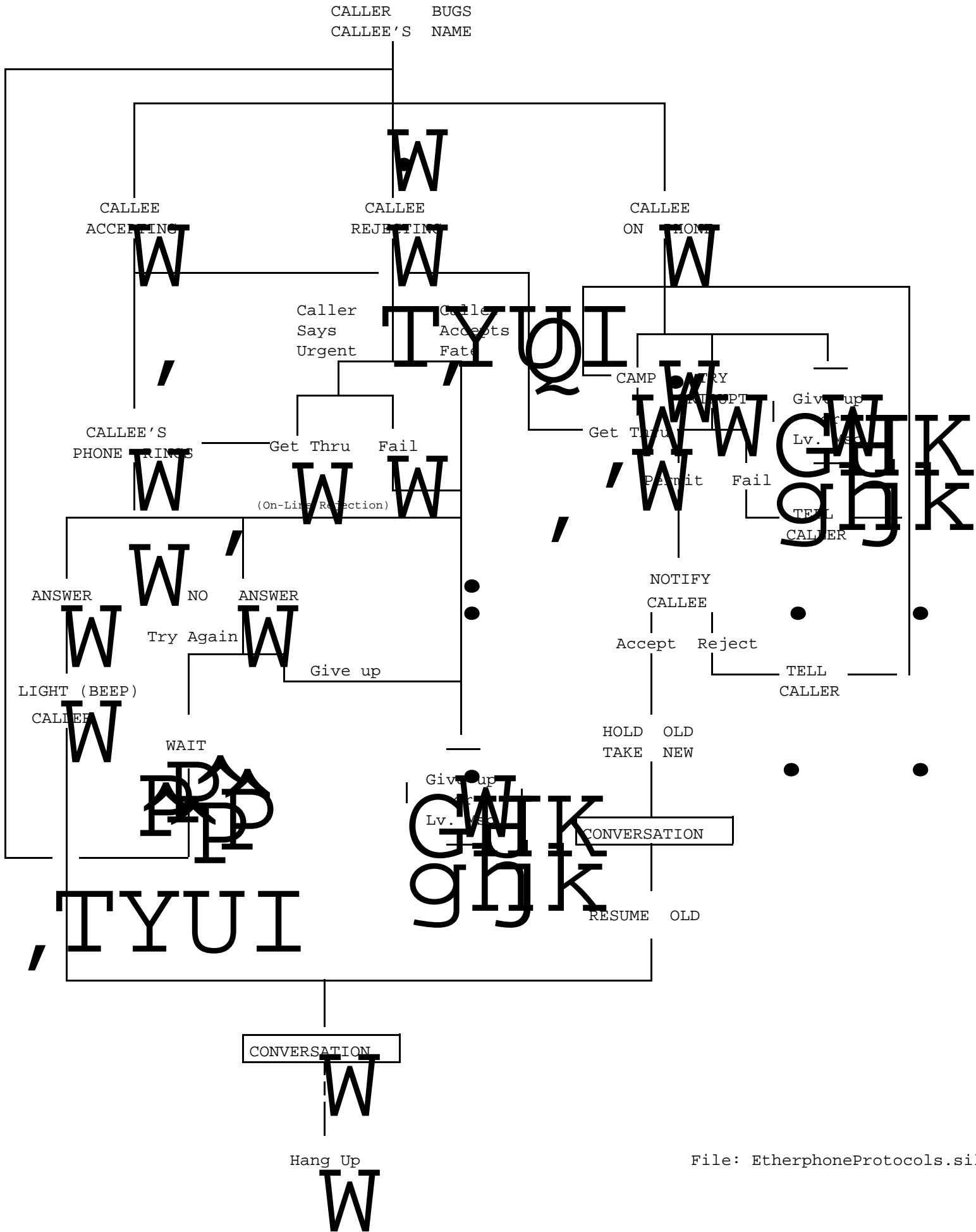

16K Main Memory Address

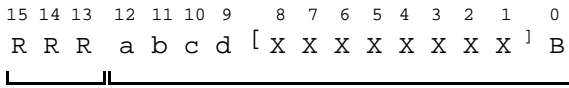

region 12 bit (8K bytes) ROM address

Region	Which Memory	Side Effects
0	ROM	—————
1	ROM	_ISR
2	Main	—————
3	Main	—————
4	Main	Rd. Mod. Wr.
5	Main	Rd. Mod. Wr.
6	ROM	OSR_
7	ROM	—————

ROM ADDRESSES

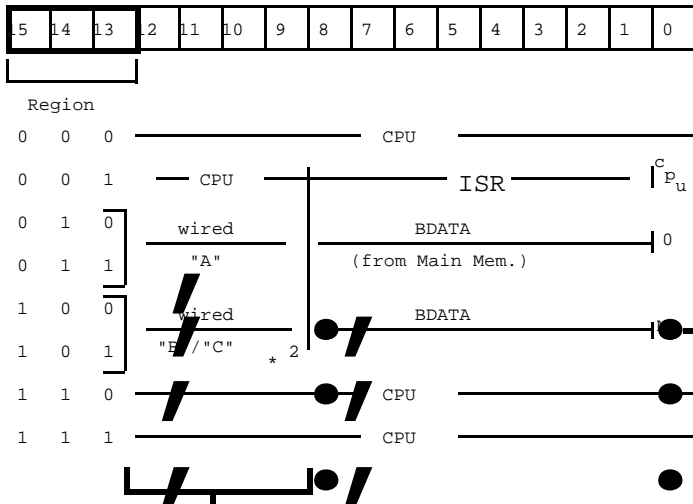

These ROM address bits are given by a ROM addressed by CPU 9-15 and PIO (which selects one of two fixed numbers {B and C} for regions 4 and 5. B and C are bases for the 0 and 5 DB loss tables.

MAIN MEM ADDRESSES

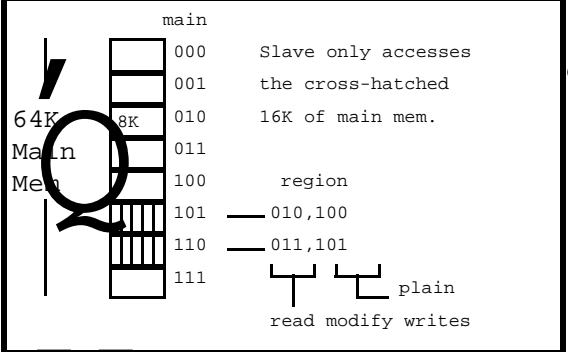
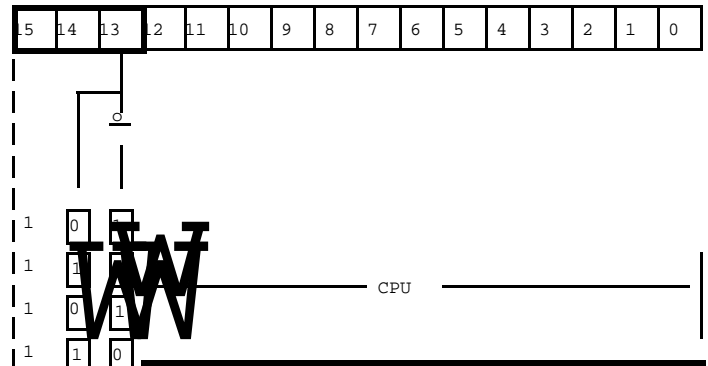

Gain Reduction and u to Linear conversion of 3 Ethernet conversations to Voice Out

Instr	M	Main Fn.	Operand	Main's Addr.
MOV	0	read/latch	Low Linear	CPU (& latch it)
	1	write 0's	High Linear	Latched
ADD	0	read/latch	Low Linear	CPU (& latch it)
	1	write 0's	High Linear	Latched
ADD	0	read/latch	Low Linear	CPU (& latch it)
	1	write 0's	High Linear	Latched

The 3 16-bit operand fetches get data from two consecutive reads of the ROM. Addr bits 1-8 are given by BDATA from Main Mem. read. Main's ref. uses bits 0-13 from the CPU. The ROM uses CPU0, the Main's contents for 1-8, and a hardwired (from another ROM) value in bits 9-12 (which locates table in ROM). During read of 2nd ROM byte, zeros are re-written into Main. On this 2nd half, ROM uses latched BDATA and Main uses the CPU bits it latched on the 1st half.

ROM CONTENTS

Region	Loc. Constraint	Nature of Contents
0,7	none	Code/whatever
1	none	256 bytes Gain 5 256 bytes Gain 0 512 bytes Silence
2,3	"A" pointer	256 bytes "straight thru"- C(x)=x
4,5	"B" pointer "C" pointer	u to linear tables 256 WORDS 0db loss 56 WORDS 5db loss
6	none	linear to u tables (2K or 4K bytes)



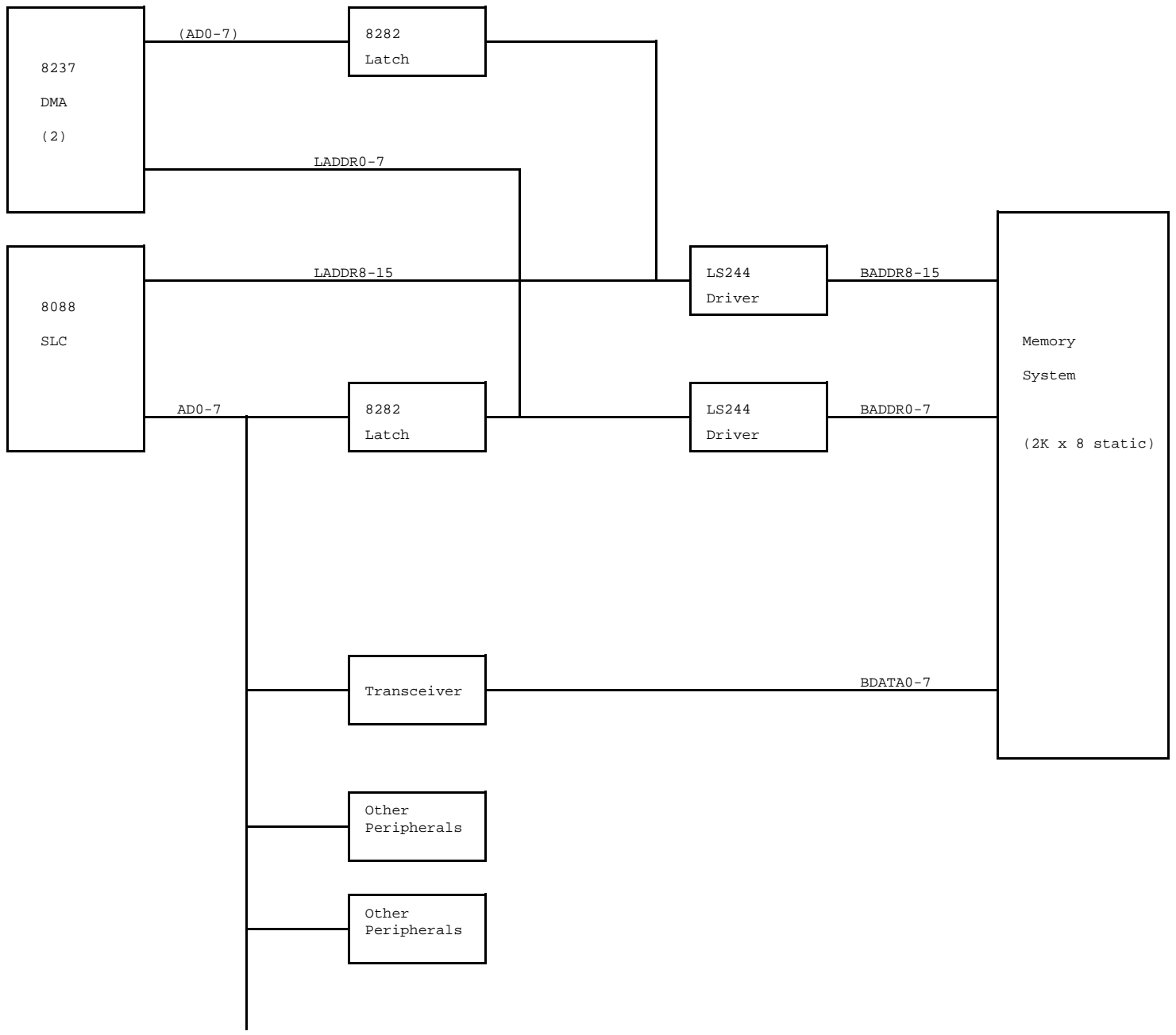

REV-Ac Design

XEROX PARC	Project Voice	Drawing BUS ARCHITECTURE	File ETPARCH01.sil	Designer L. Stewart	Rev	Date 01/20/81	Page
---------------	------------------	-----------------------------	-----------------------	------------------------	-----	------------------	------

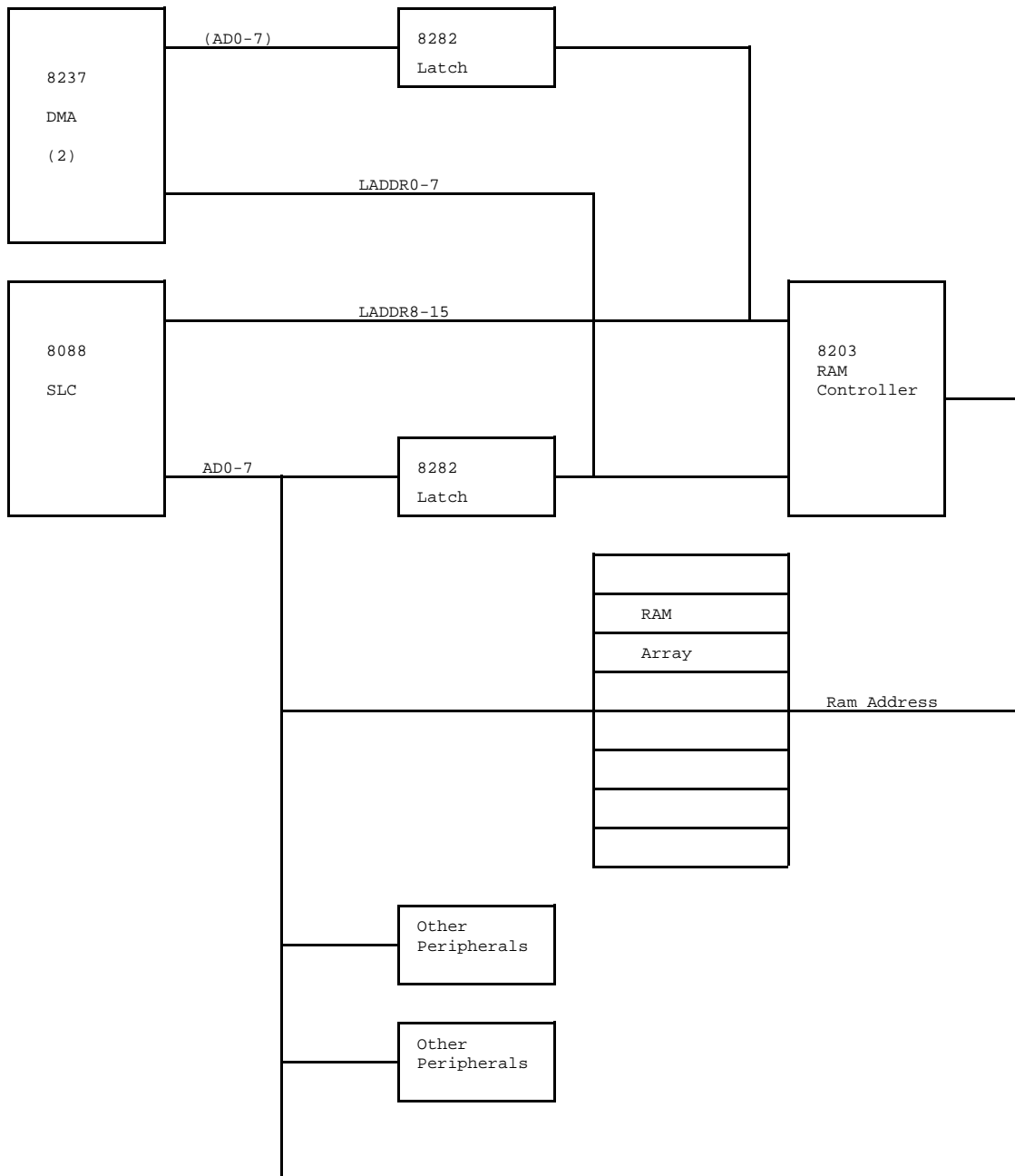

REV-Ac Design using dynamic memories

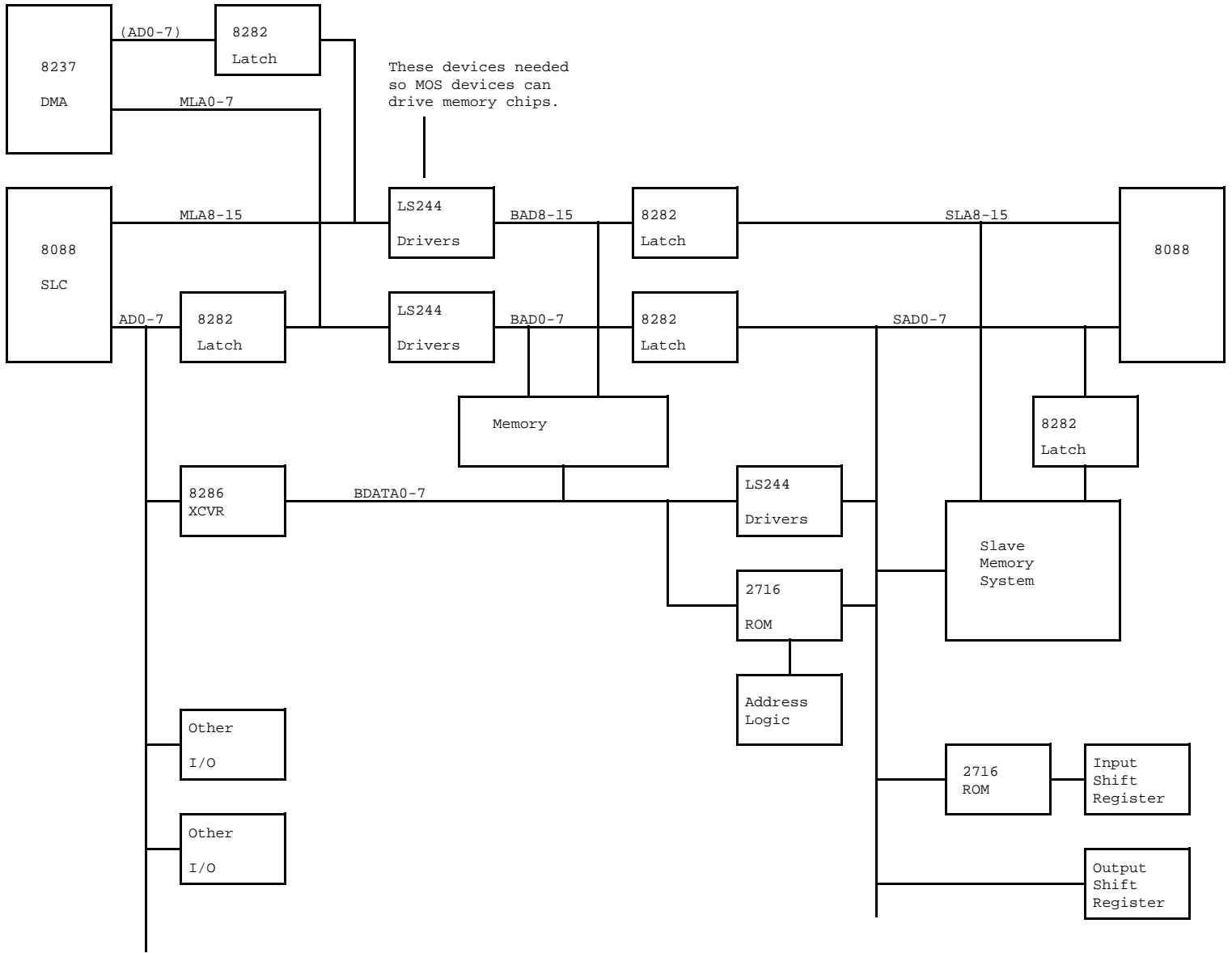

Dual 8088 system busses

XEROX PARC	Project Voice	Drawing BUS ARCHITECTURE	File ETPARCH03.sil	Designer L. Stewart	Rev	Date 01/20/81	Page
---------------	------------------	-----------------------------	-----------------------	------------------------	-----	------------------	------

Latches needed because byte references are done to main memory while slave system does word reference (address could change for second byte).

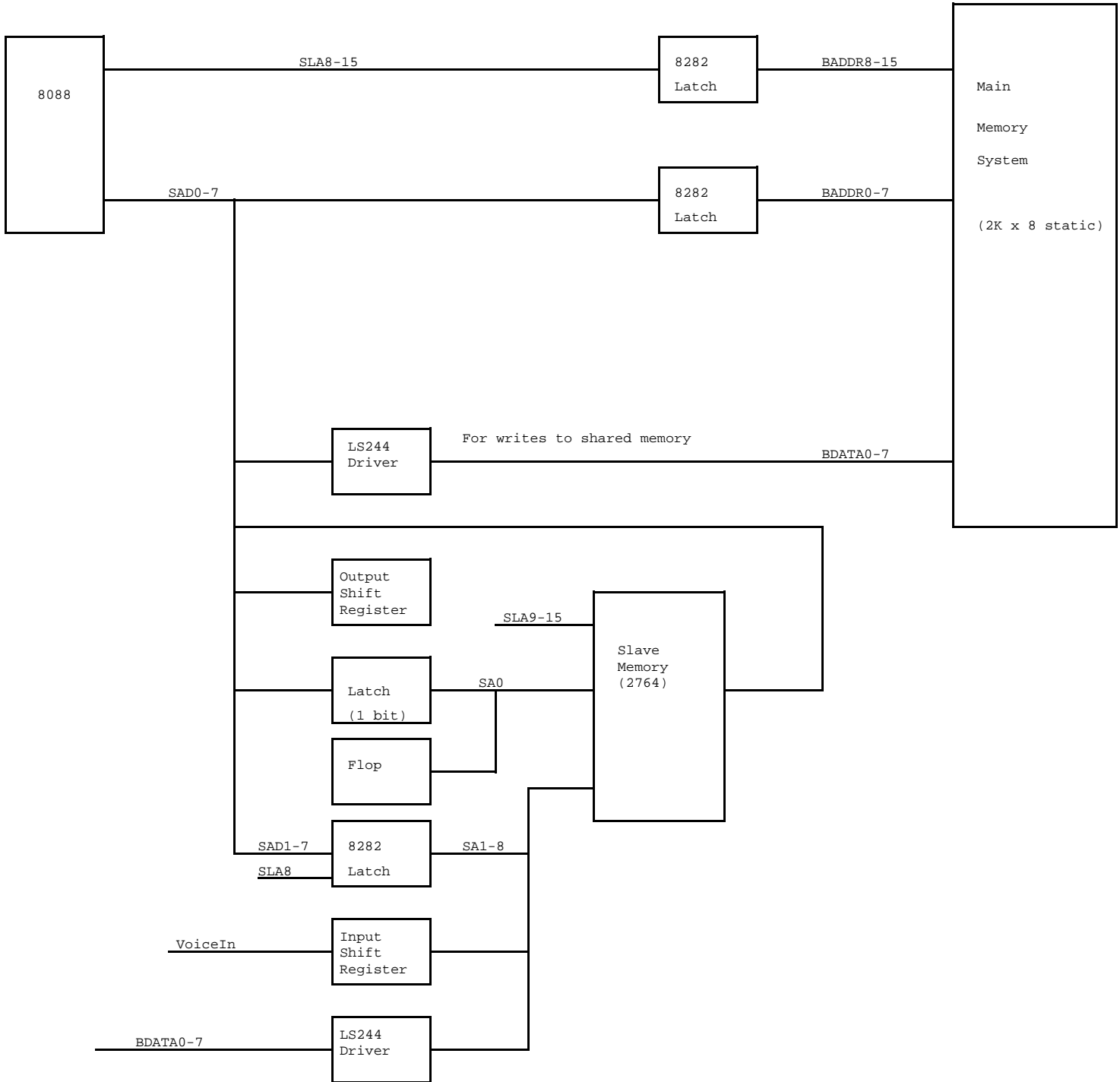

Slave System

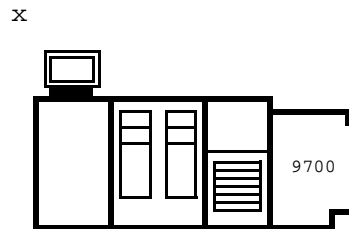
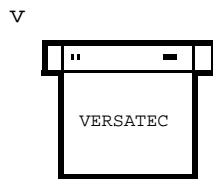
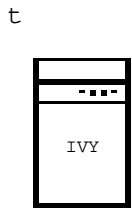
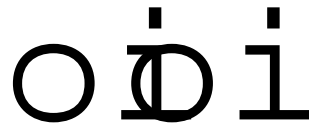
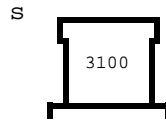
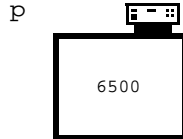
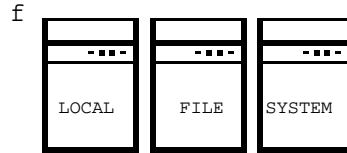
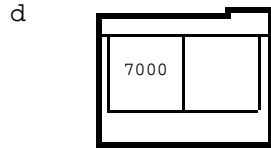

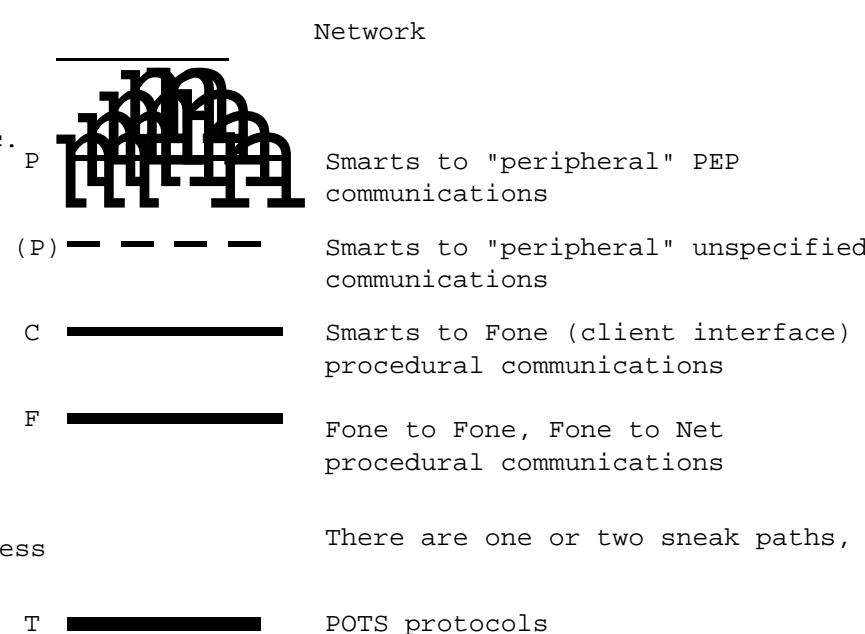
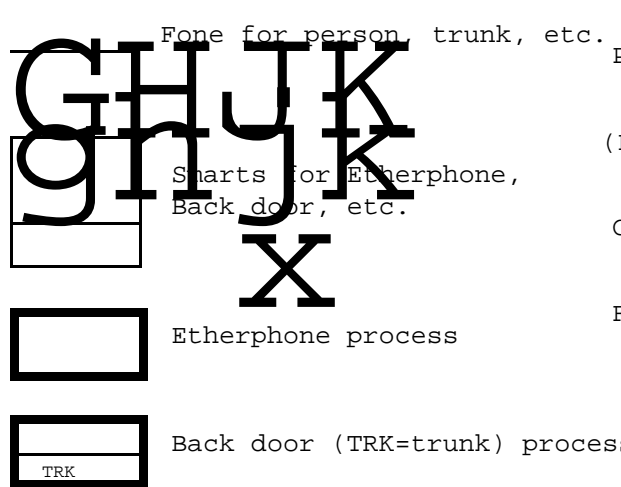
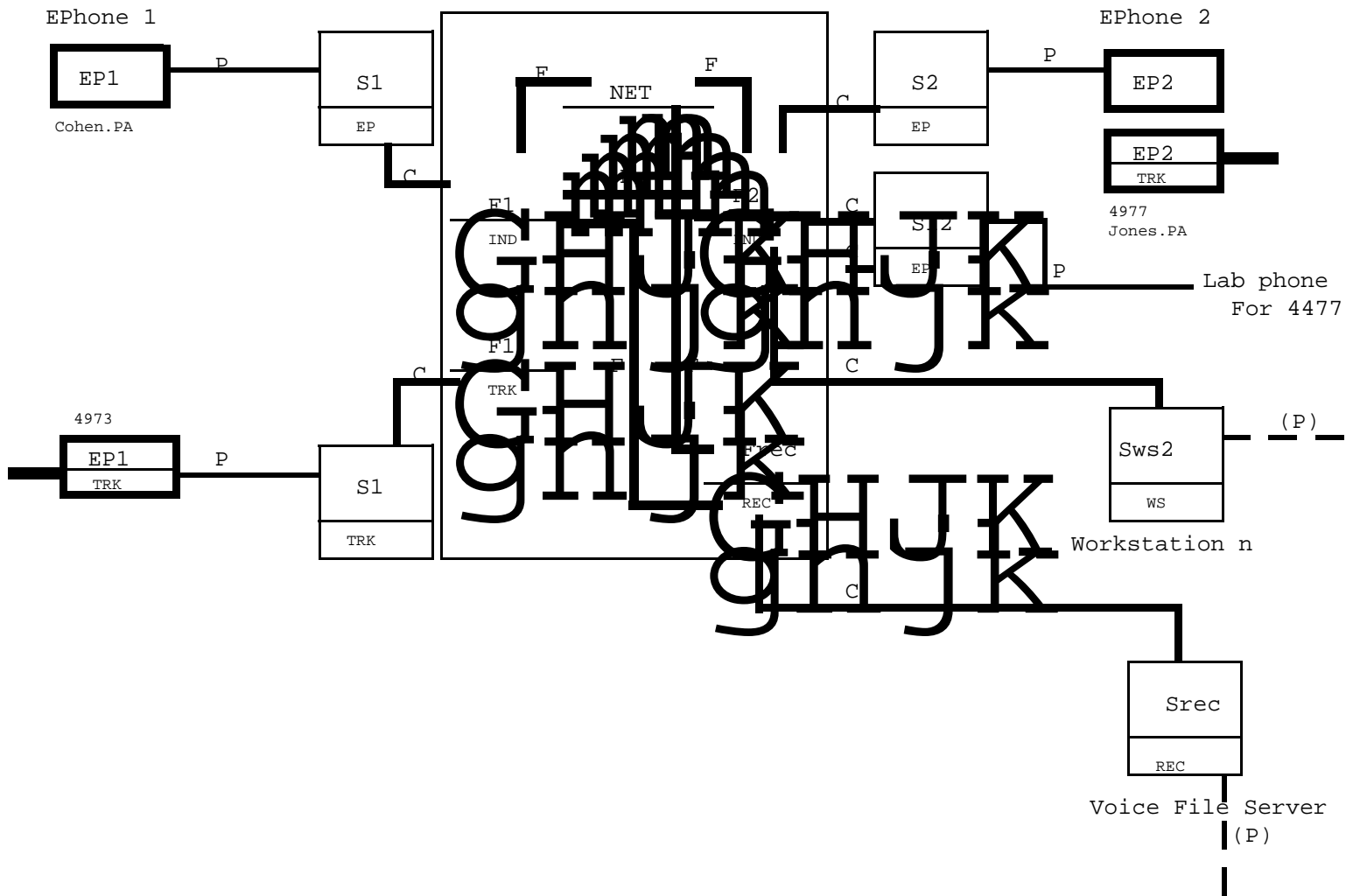

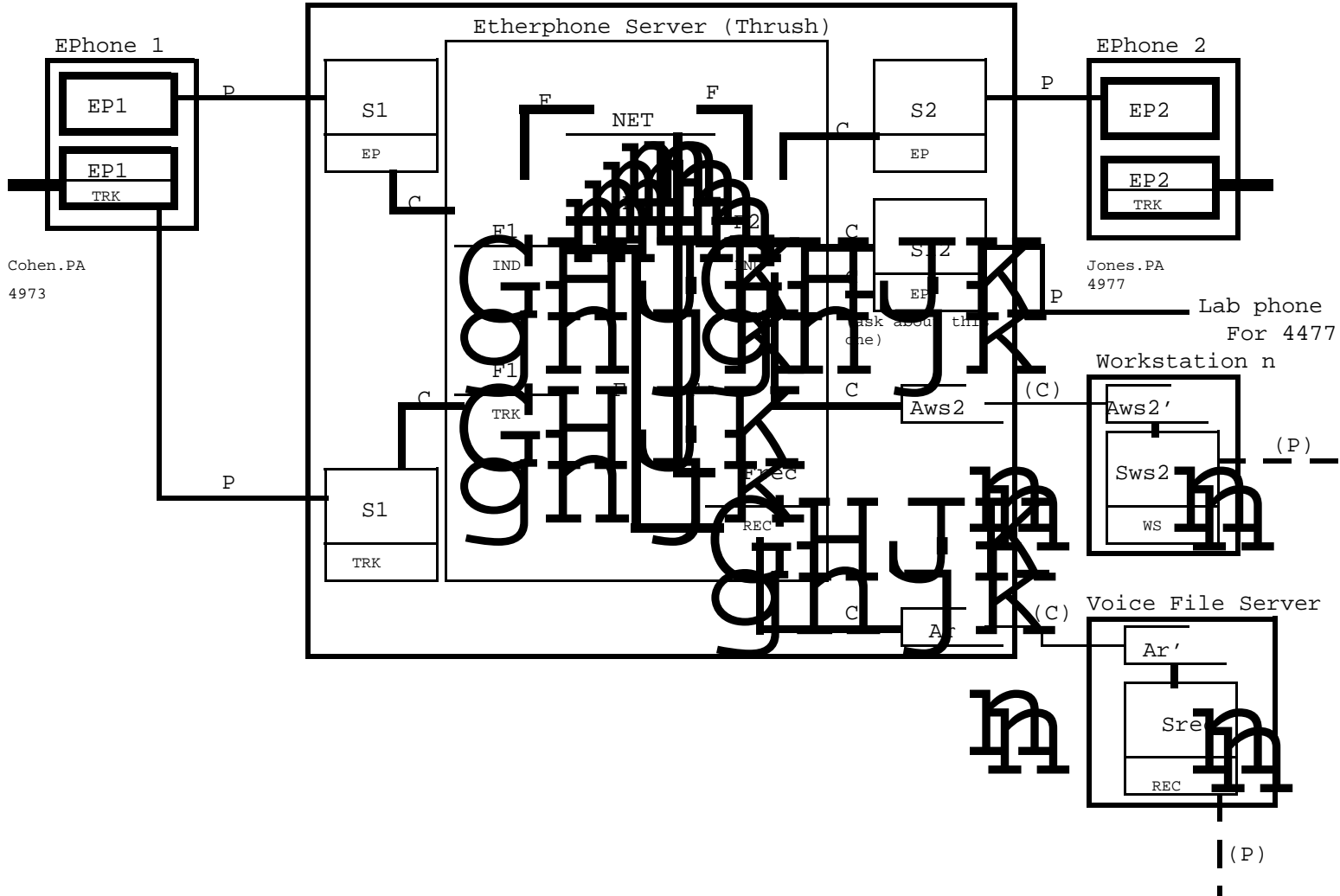

Network

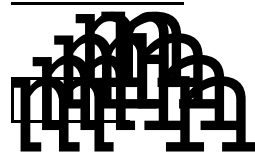

Communications Agent  
For Smarts (e.g., RPC stub & runtime)

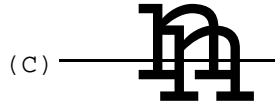

(C) Smarts to Agent PEP communications



P Smarts to "peripheral" PEP communications



(P) Smarts to "peripheral" unspecified communications



C Smarts to Fone (client interface) procedural communications



F Fone to Fone, Fone to Net procedural communications



Fone for individual, trunk, etc.

Smarts for Etherphone, Back door, etc.



Etherphone process

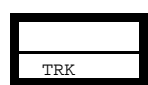

Back door (TRK=trunk) process



T POTS protocols

There are one or two sneak paths, t