

L A R K
E T H E R P H O N E S C H E M A T I C S

Table of contents

<u>TITLE</u>	<u>Page</u>
Processor and Clock	01
Address Buffers/Selects	02
DMA's and Parallel I/O	03
Timer and Interrupts and WD Encrypt	04
Audio Input/Output	05
SLC	06
Serial Line Controllers	07
8K ROM	08
RAM 0 - 16K	09
RAM 16K - 32K & Audio Output Memory	10
External Connections and PLATS	11
External Cables	12

REFERENCE FIGS

System Block Diagram	36
Miscellaneous	37
Lark Layout Rules	38
Lark Layout UPPER LEFT	39
Lark Layout UPPER RIGHT	40
Voice Font 9 Pictures	41
Voice Font 9 Pictures (more)	42
Voice Font 8 Library and pictures	43
Voice Font 9 Library	54

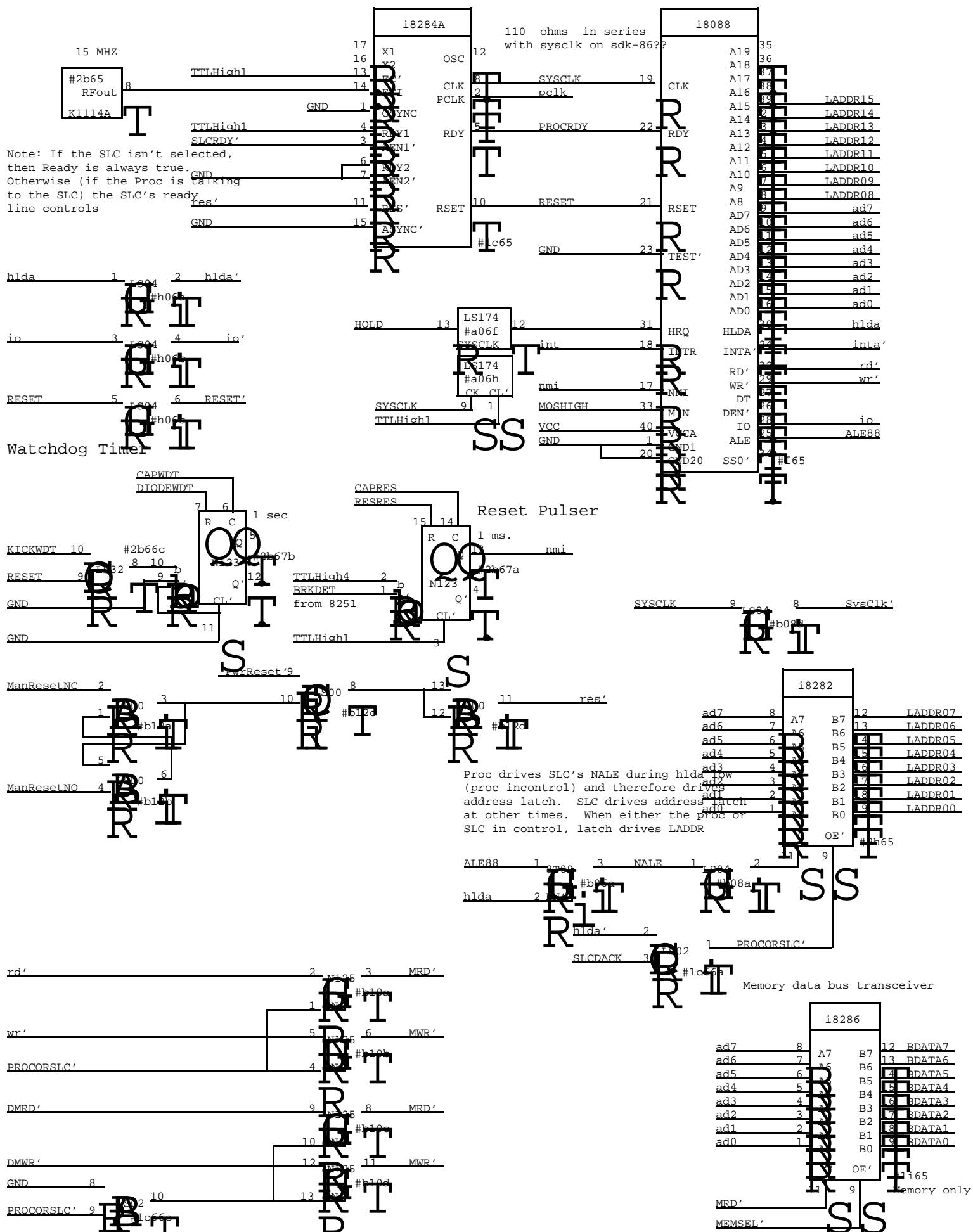

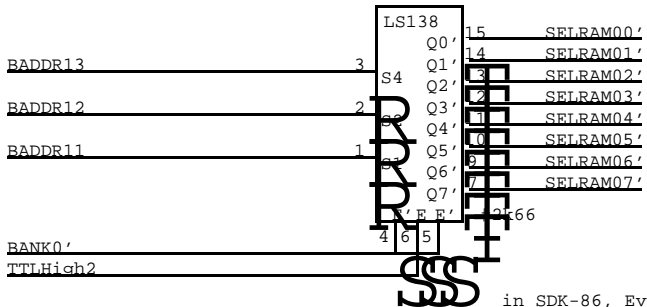
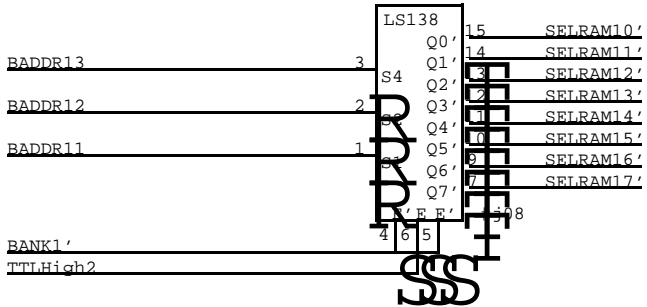
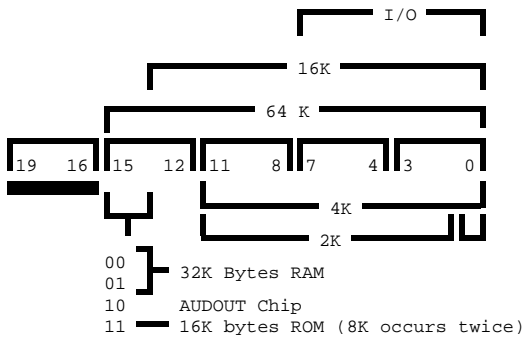

in SDK-86, Even addresses are in one chip, odd in another.

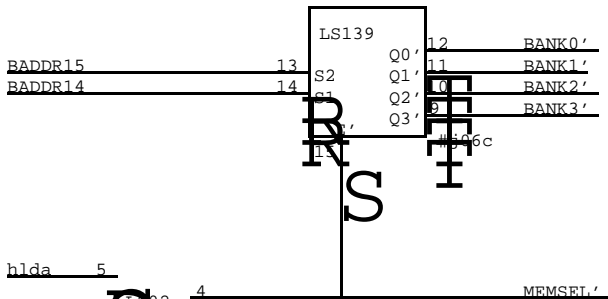
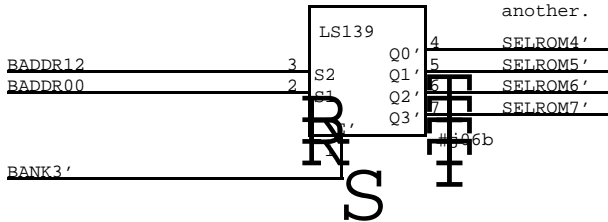

DMA access or Proc selecting memory

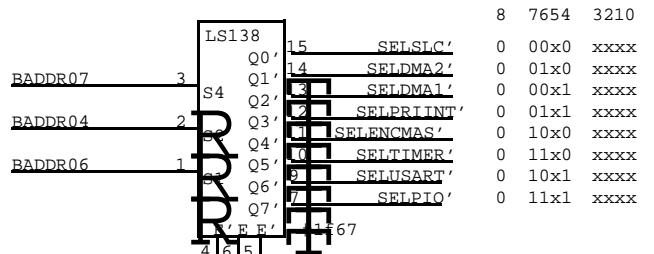
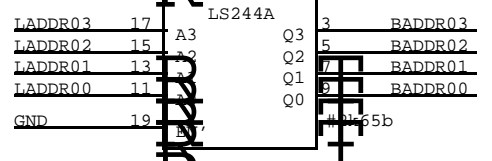
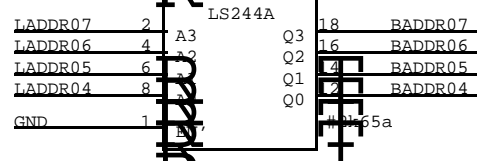
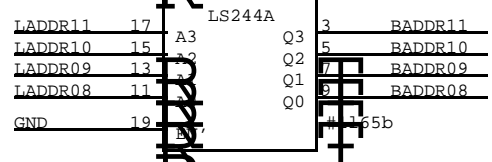
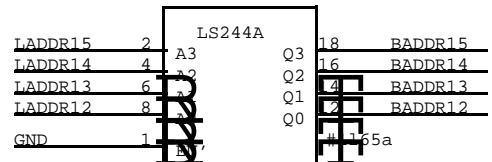
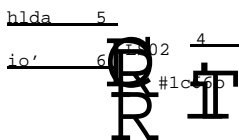

It is mandatory to address the SLC with addresses in the 20's

The SLC decodes the low 8 address bits

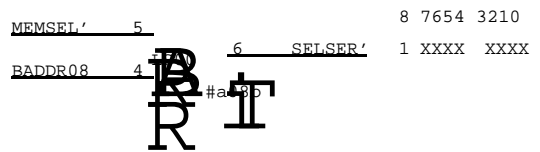

Parallel I/O

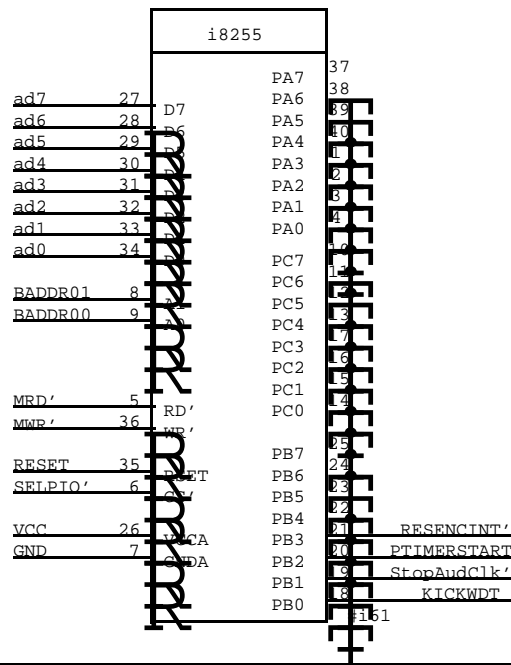

DMA's

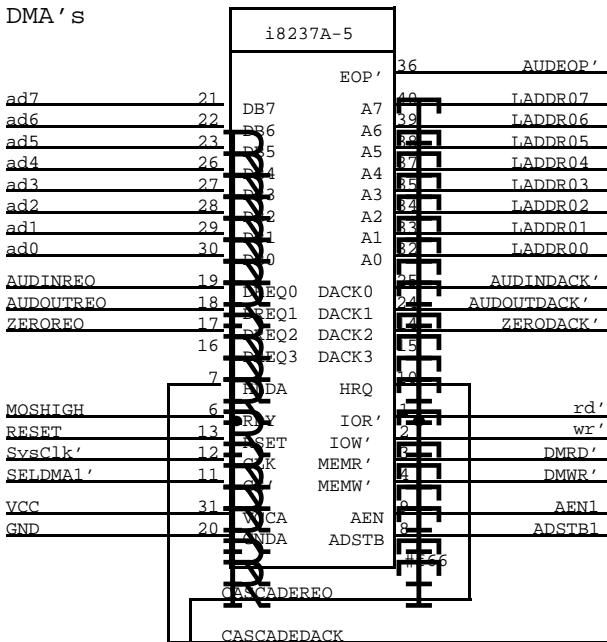

the DMA's are programmed for neg true DACK's - positive true REQ's

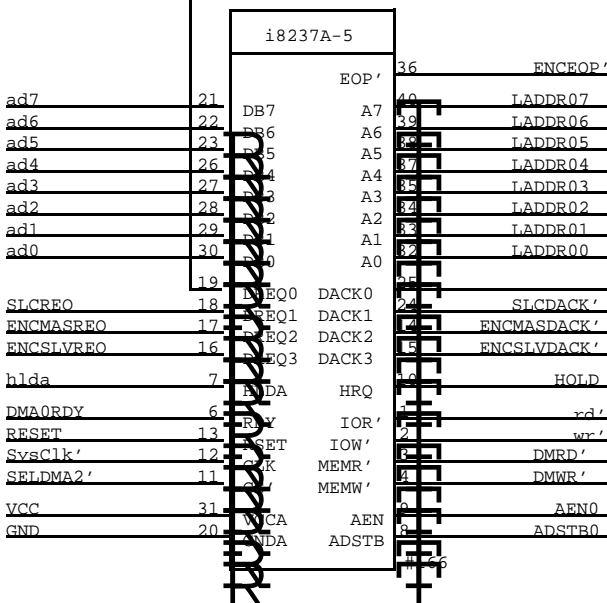
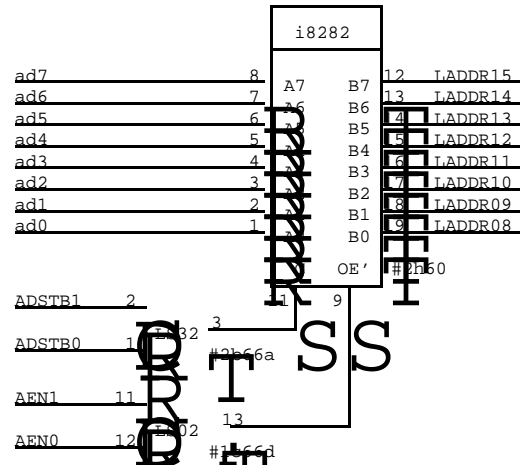

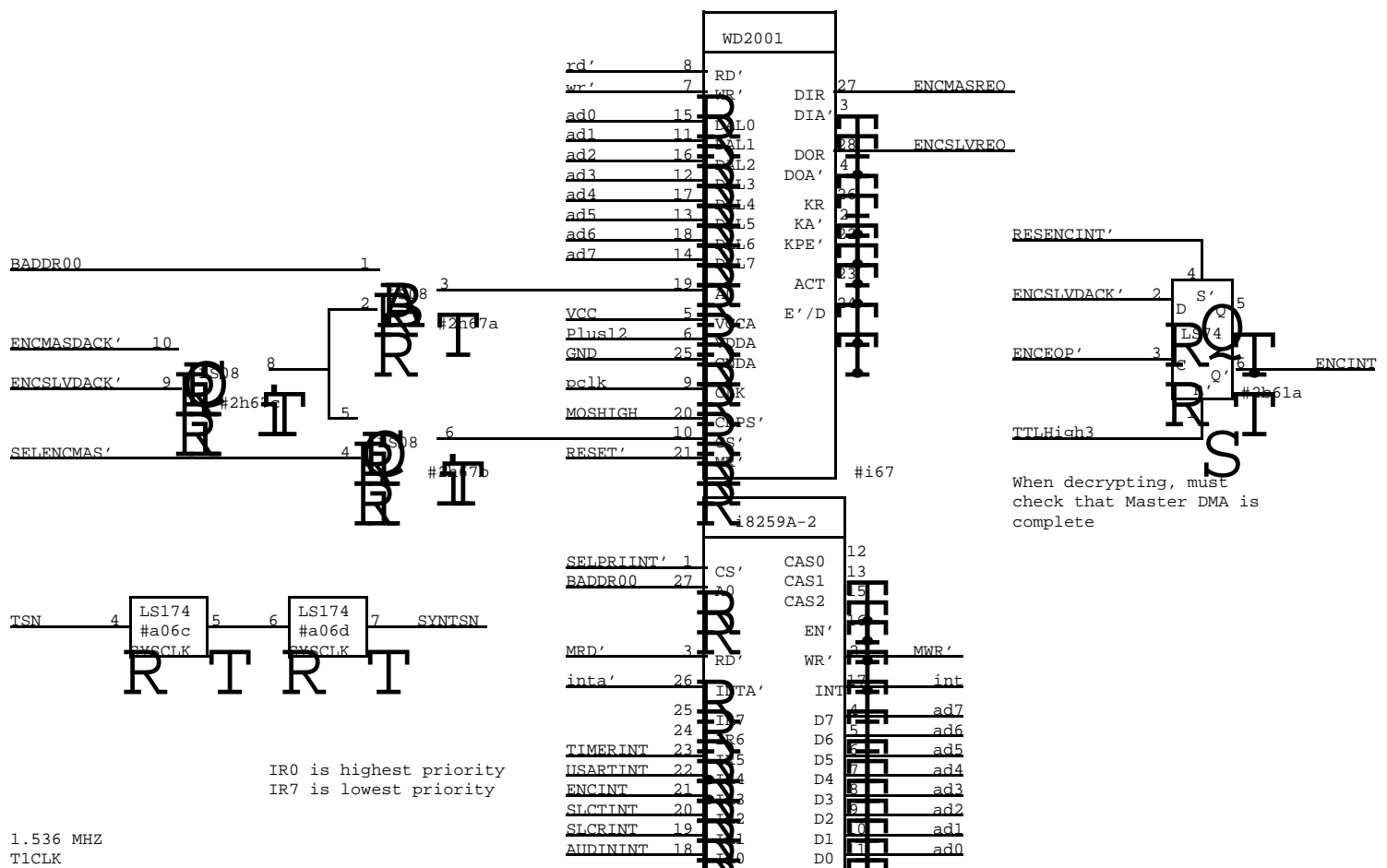

IR0 is highest priority
IR7 is lowest priority

1.536 MHZ
T1CLK

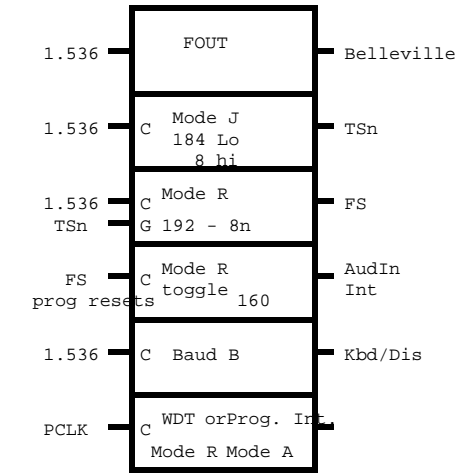
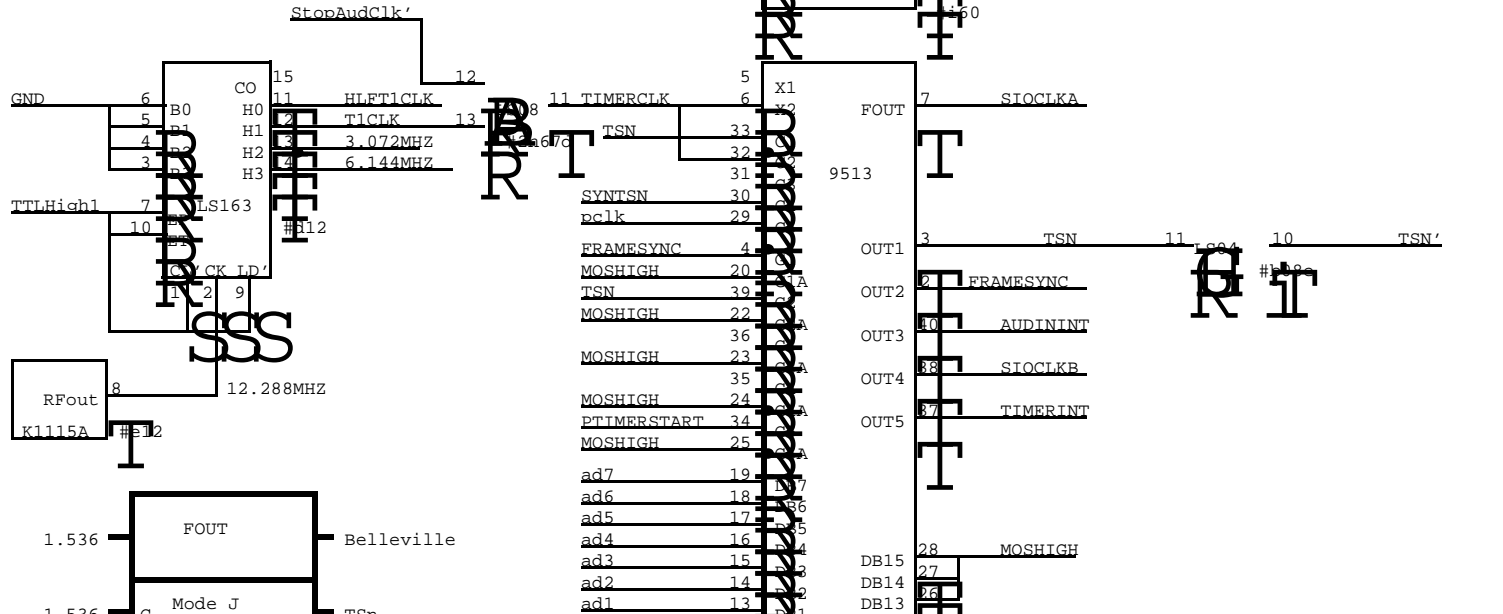

SIOCLKA POSSIBILITIES	
9513 DIVISIONS	8274 Divisions
1.536 / 80 (16 x 5) = 19,200	/ 16 = 1200
	/ 32 = 600
	/ 64 = 300
1.536 / 10 (1 x 10) = 153,600	/ 16 = 9600
	/ 32 = 4800
	/ 64 = 2400
1.536 / 5 (1 x 5) = 307,200	/ 16 = 19,200
	/ 32 = 9600
	/ 64 = 4800

INPUT

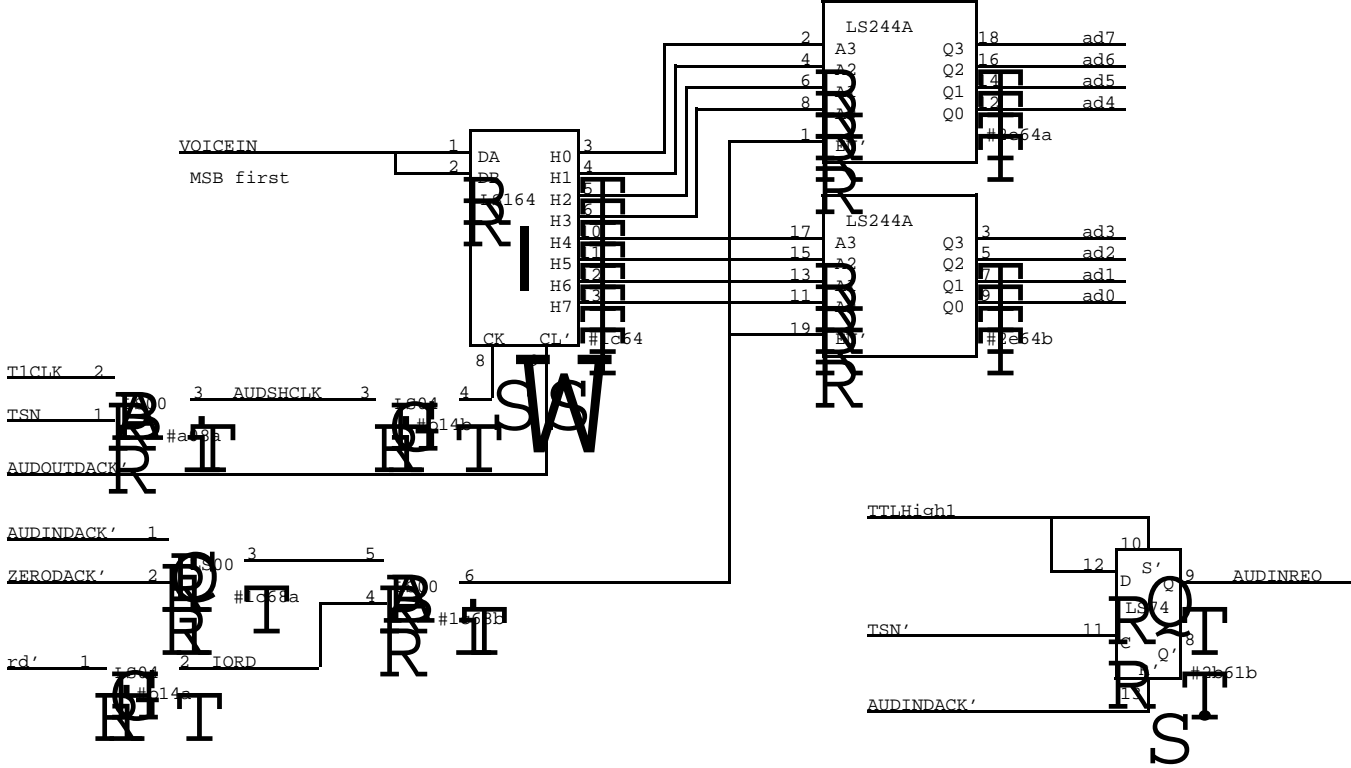

OUTPUT

Using 74165 shifter might save agate

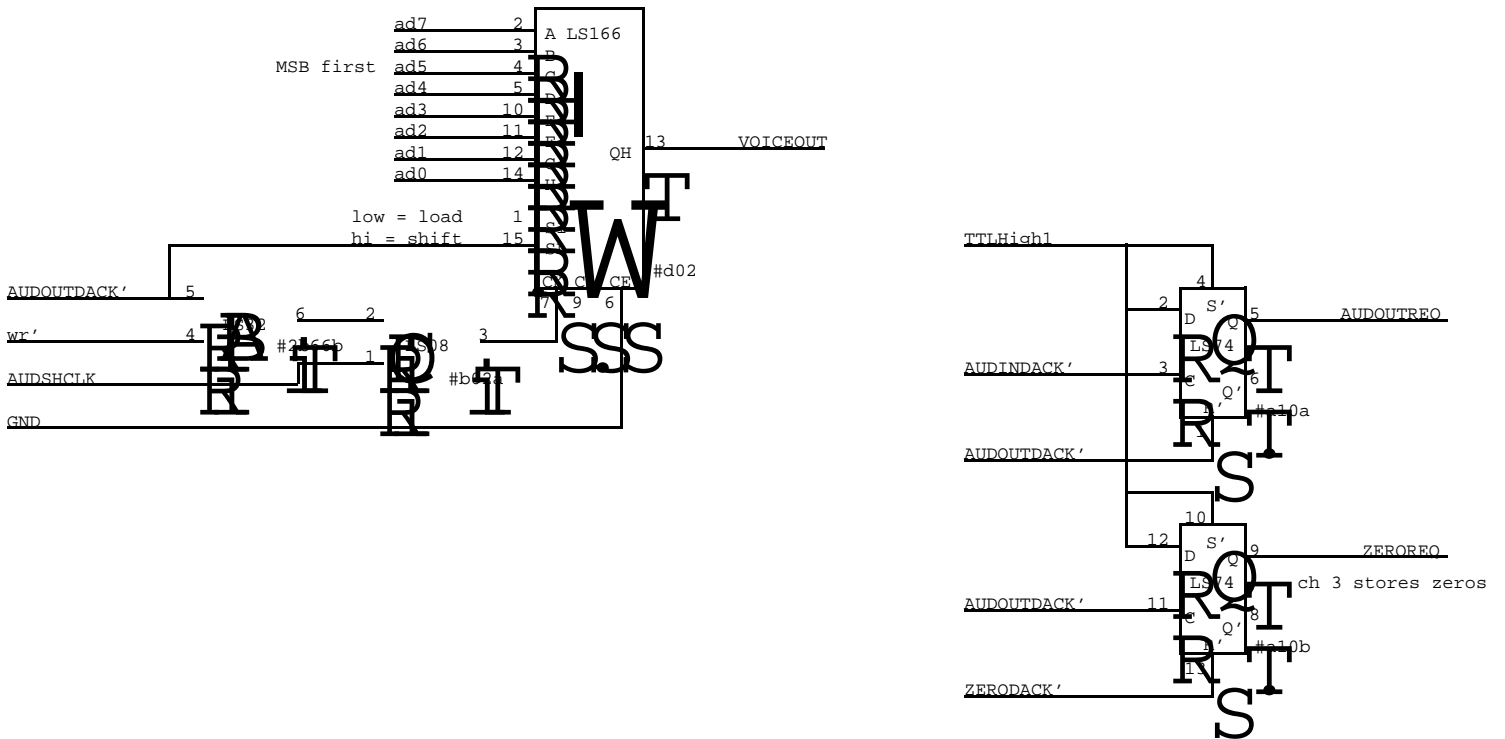

ETHERNET DRIVE/RECEIVE

ALL lines are TP with gnd from edge

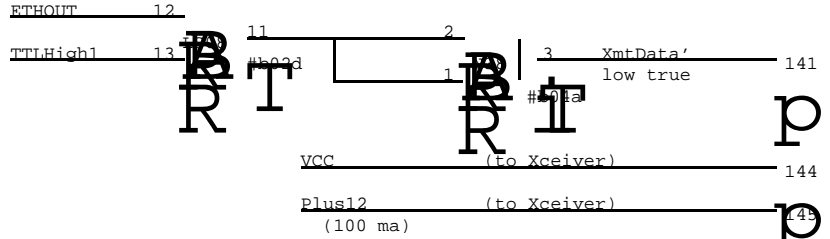
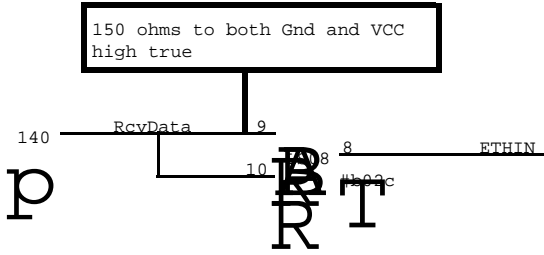

Must use Dorado transceiver in order to use +12 instead of +15.

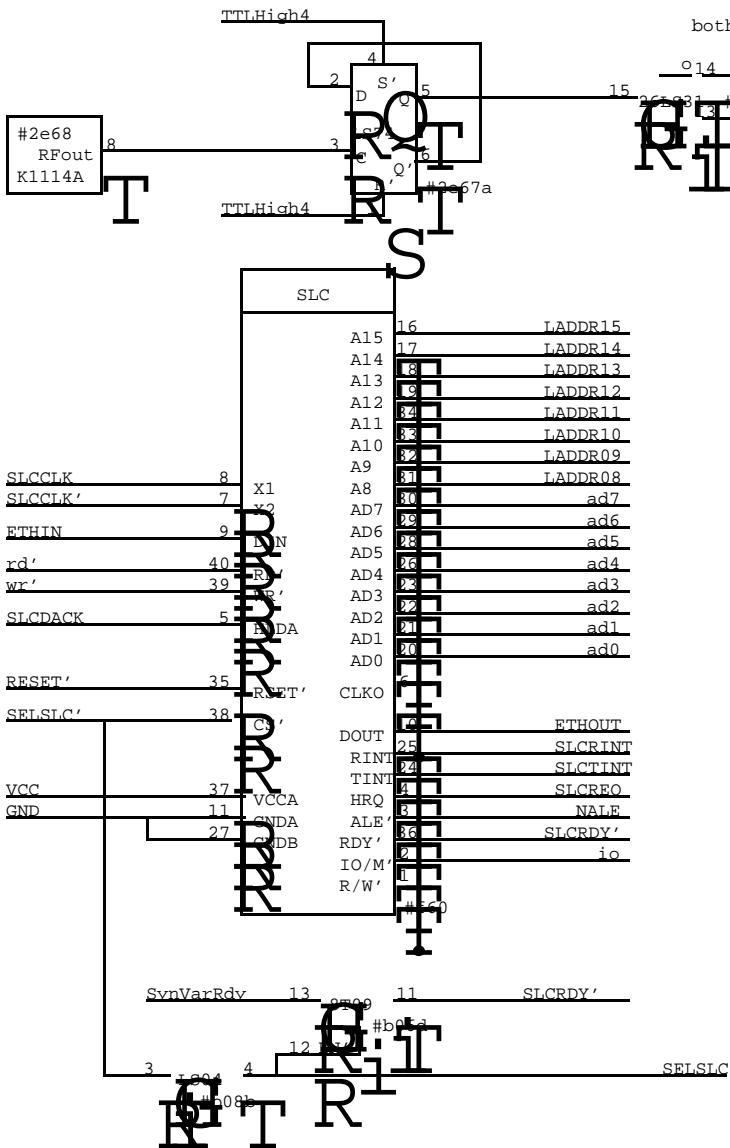

both sides have 2K ohm pullups to VCC

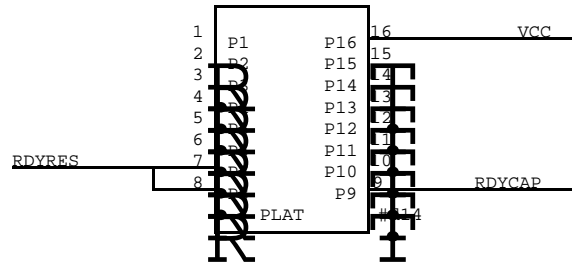
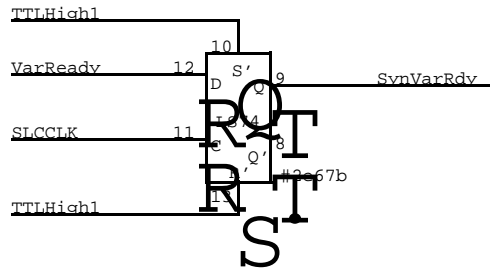
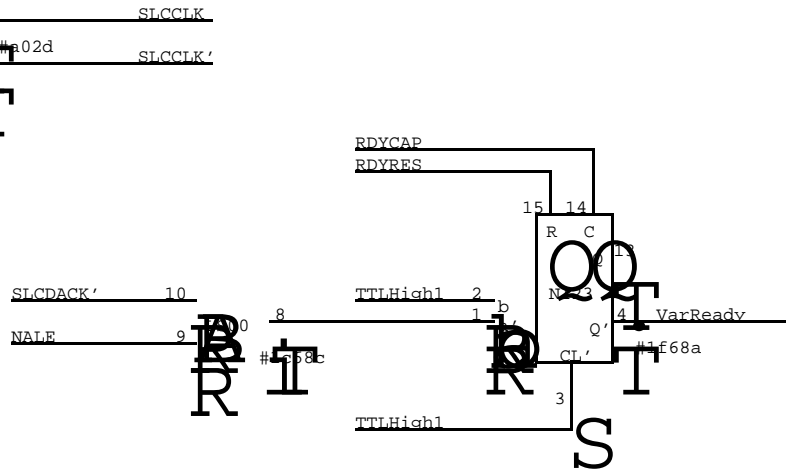

SLCRDY' is held low except when the SLC is selected - in which case, the SLC's own RDY controls the line

BELLEVILLE

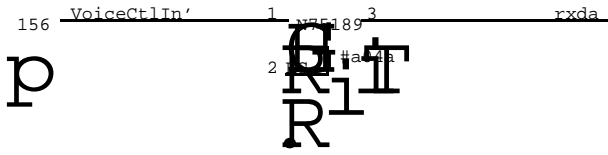

LARK IIB Display

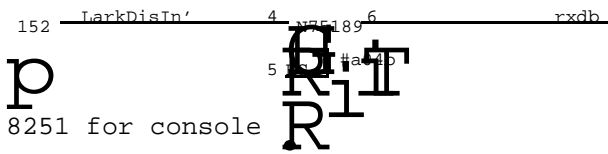

8251 for console

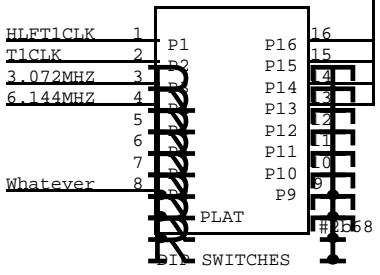
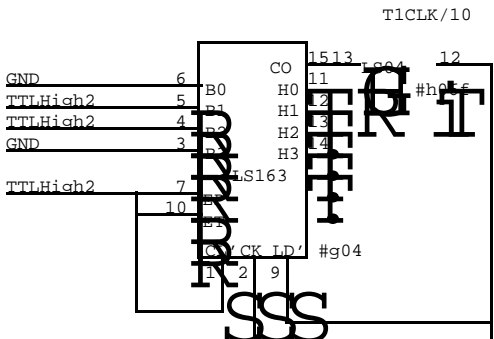
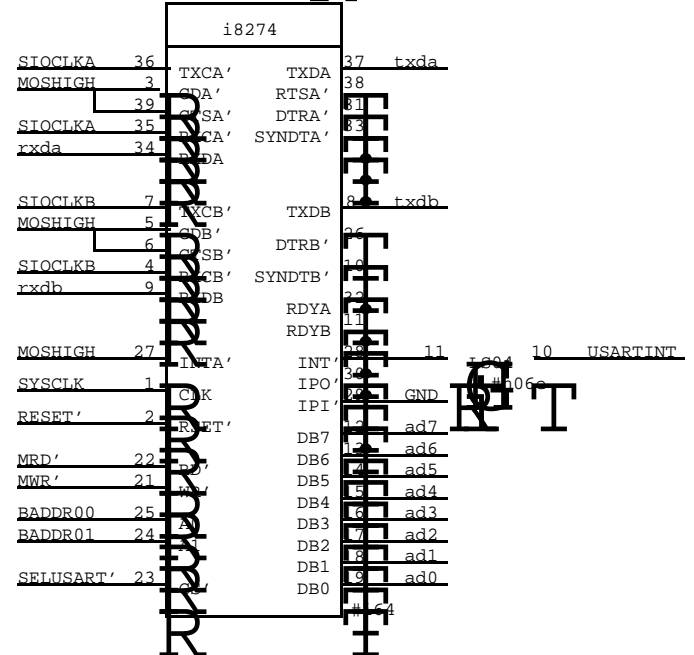
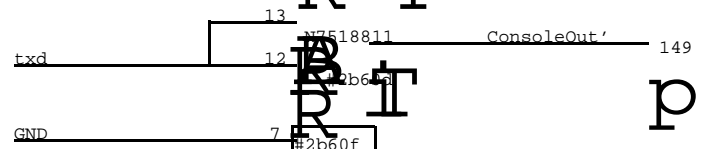
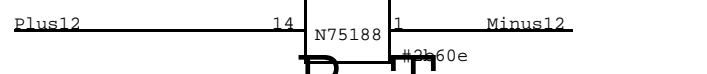
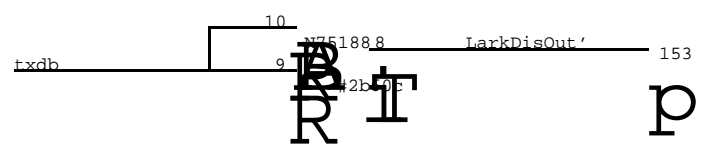
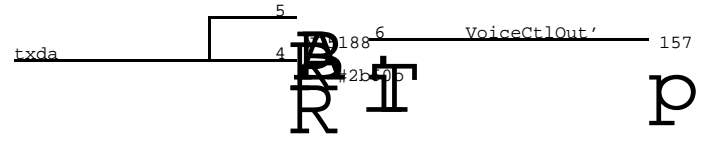
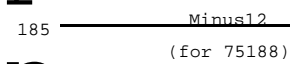
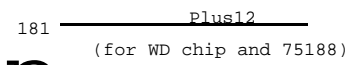
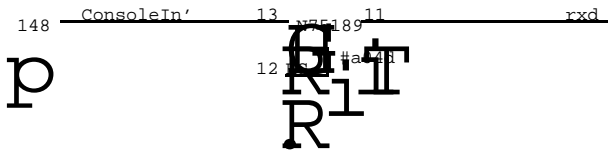

To enable WD Timer, switch 7 is closed and switch 8 open.
To disable, reverse them.

BRKDET goes high after two characters of spacing
returns low on master reset or when RxData returns to marking.

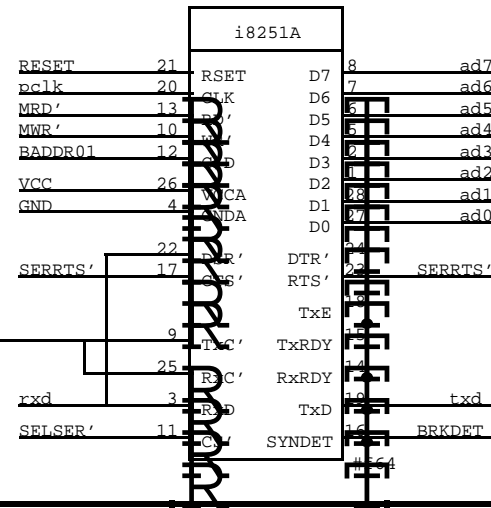

FF000 - FFFFF odd bytes only

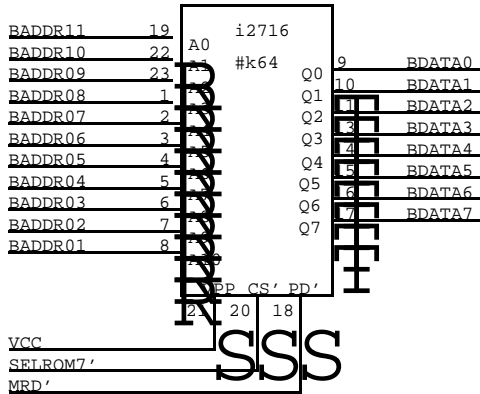

The two highest EPROMs hold the monitor. Because the monitor is from an 8086 system, the EPROMs were set up for a 16 bit bus. For an 8088 system, therefore, the two EPROMs hold the even and odd bytes...

FF000 - FFFFF even bytes only

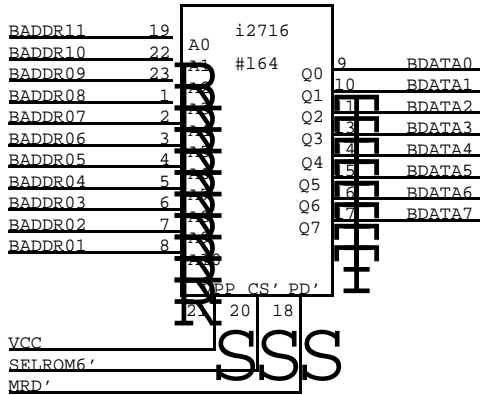

FE000 - FEFFF odd bytes only

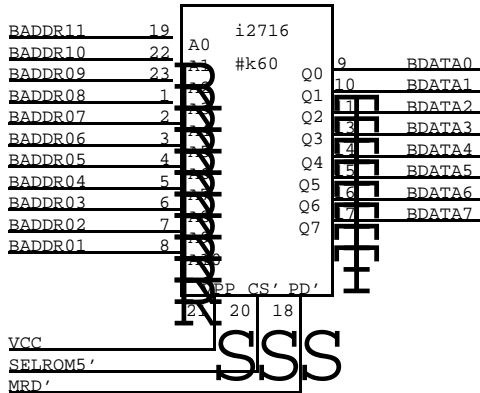

The other EPROMs will not immediately exist, but they are also set up for even and odd bytes. You must use both at once.

FE000 - FEFFF even bytes only

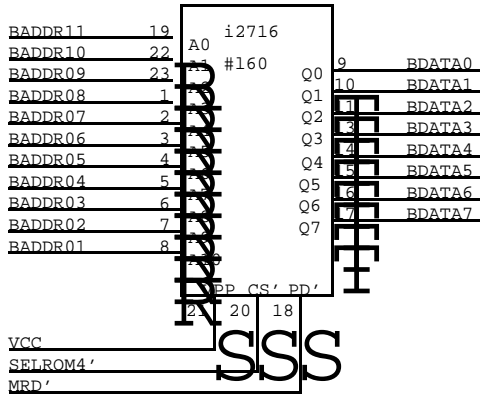

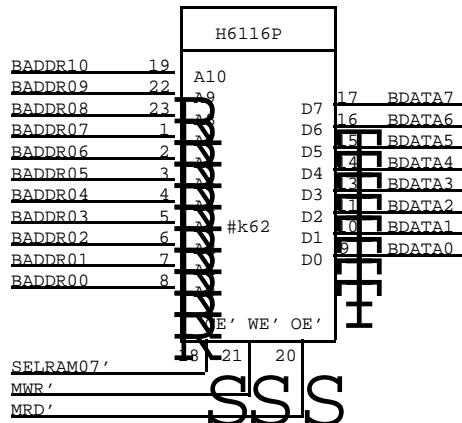
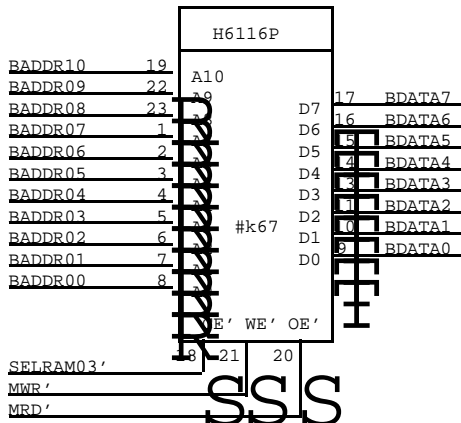
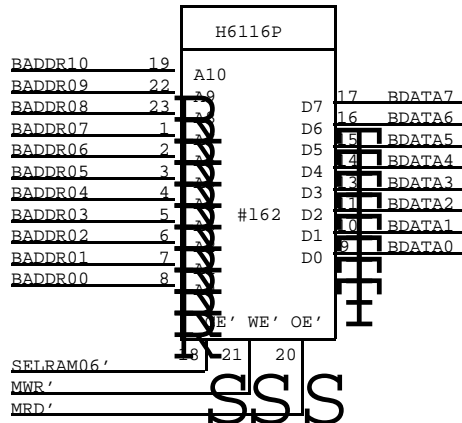
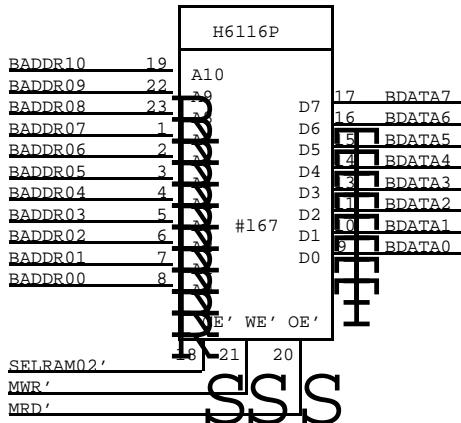
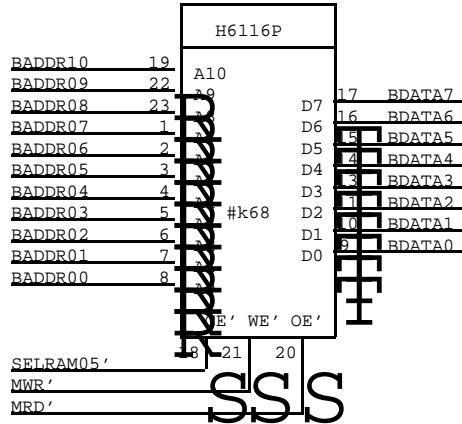
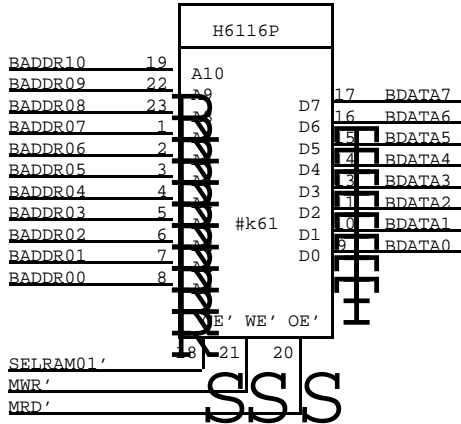
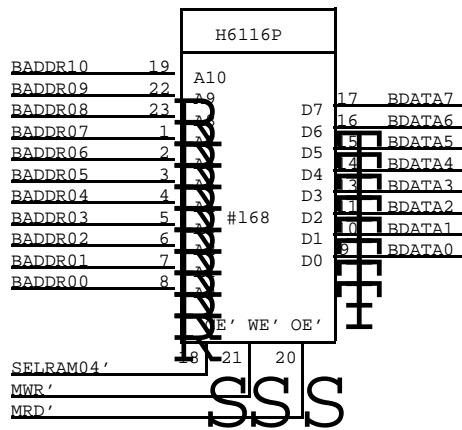
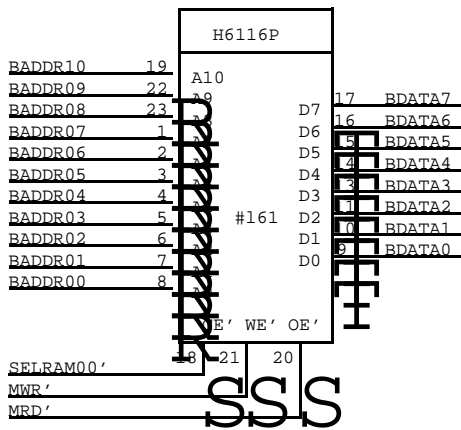

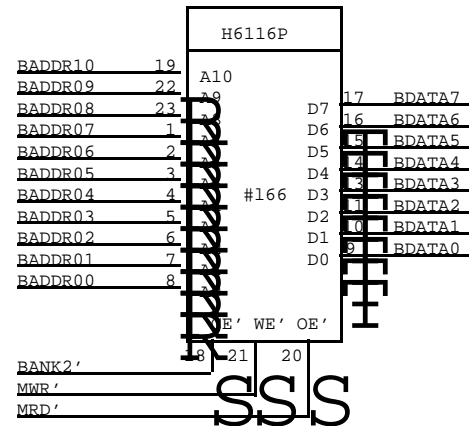
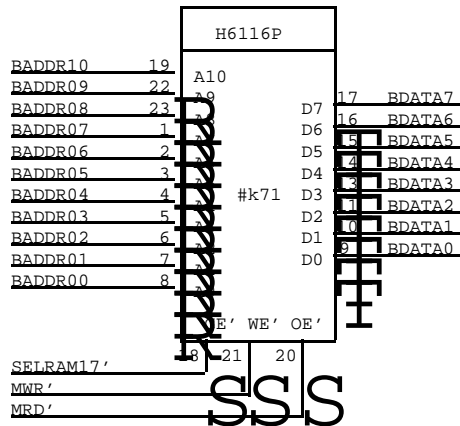
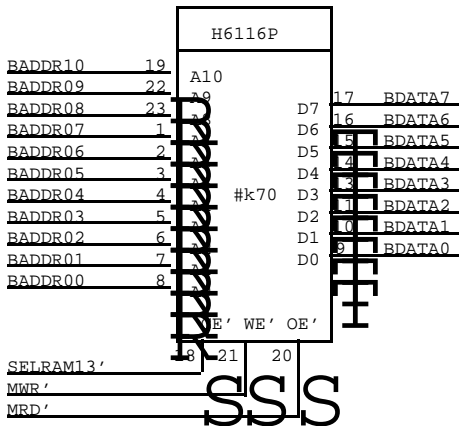
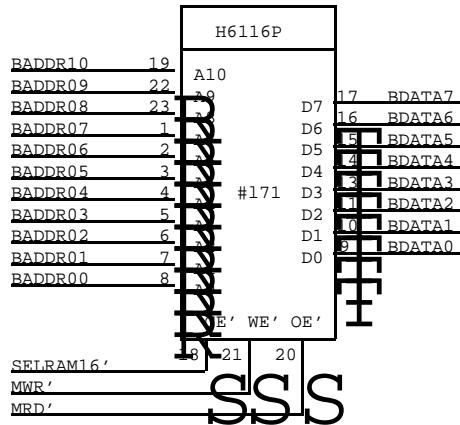
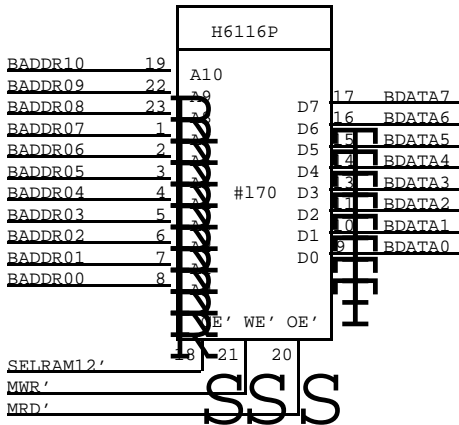
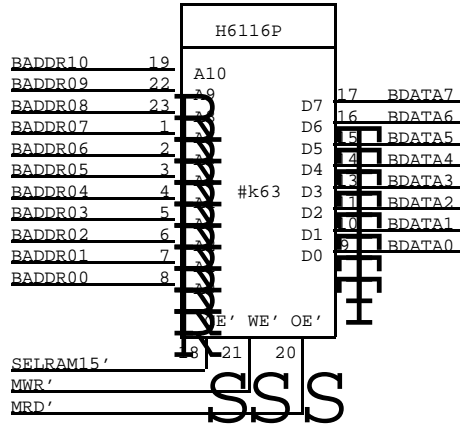
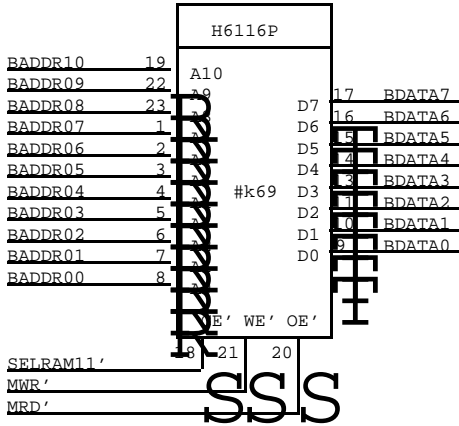
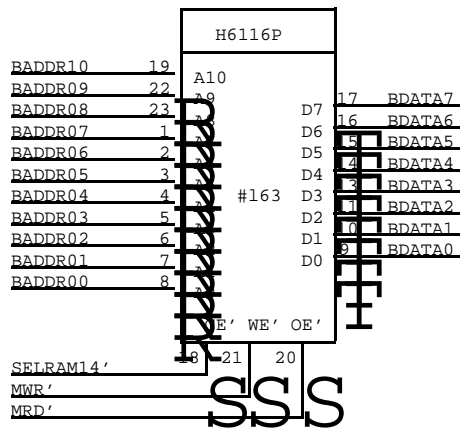
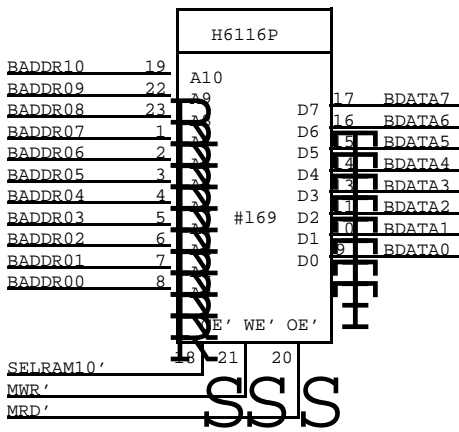

2K bytes of Audio Output
Repeats throughout the
third (10) 16K quadrant
of memory space

VOICE I/O

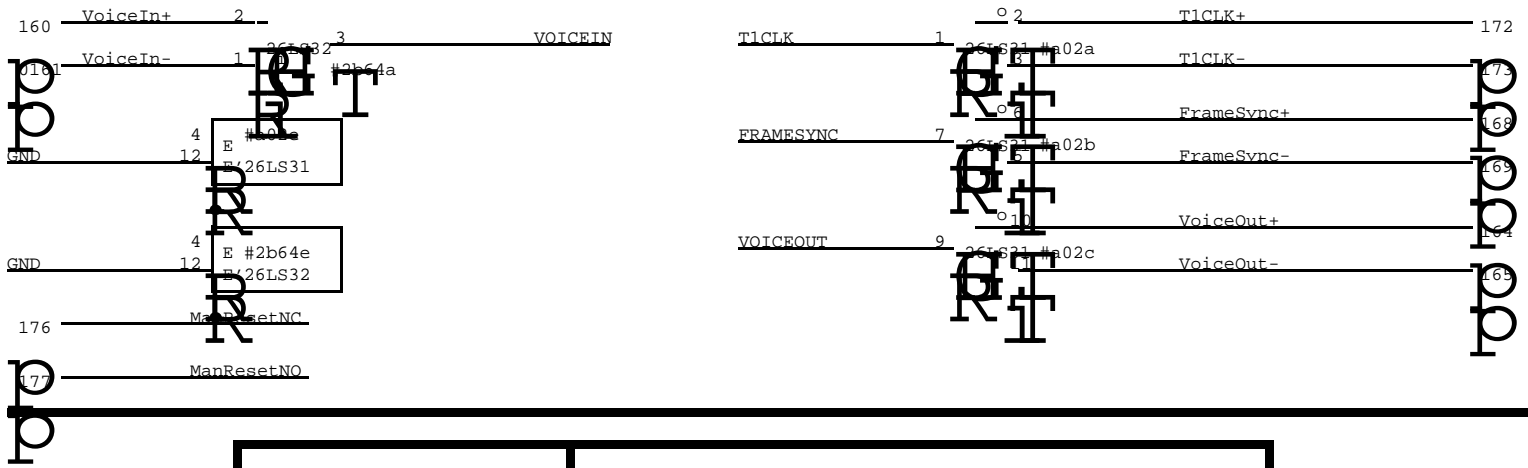

PLATFORMS

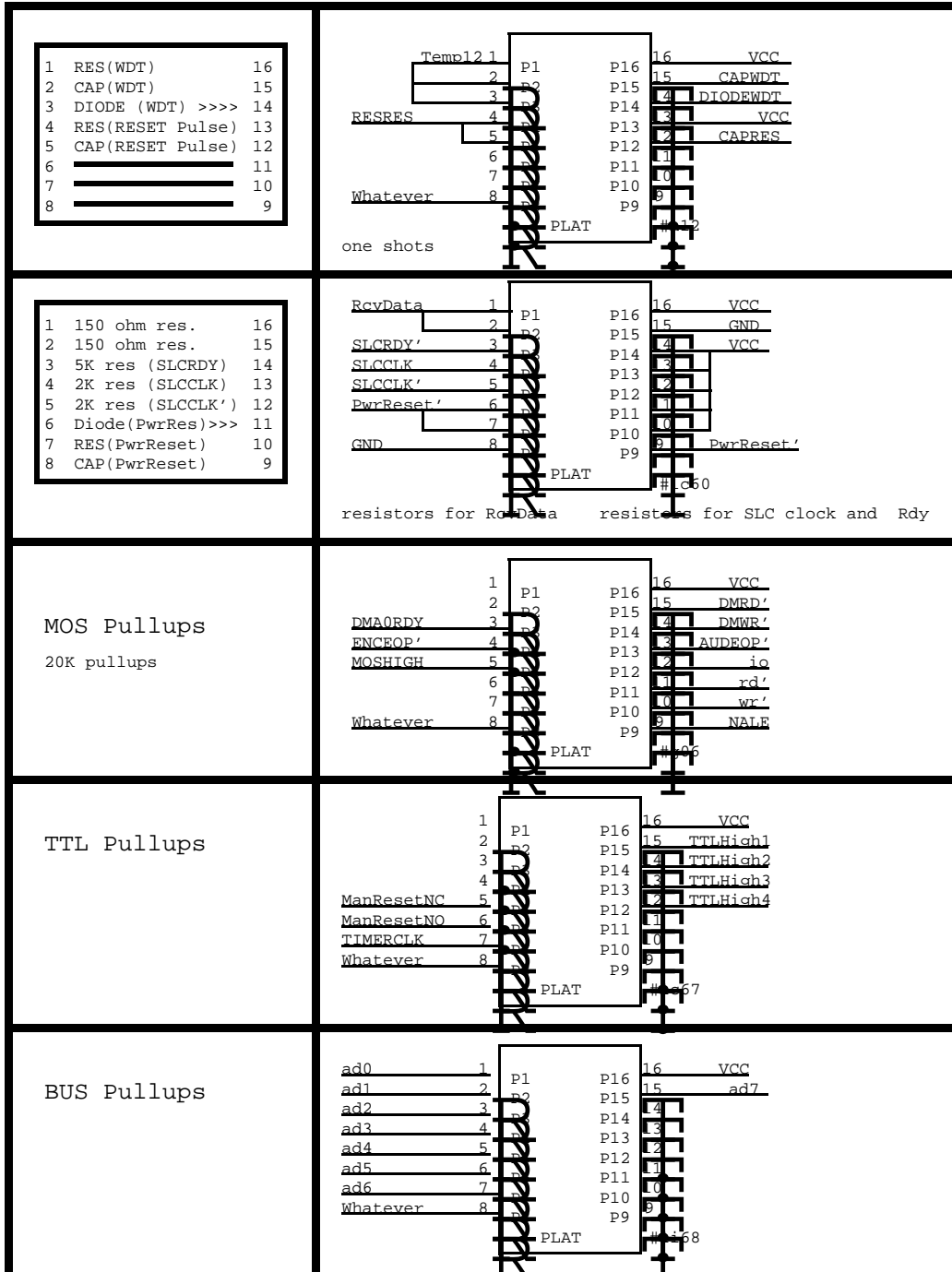

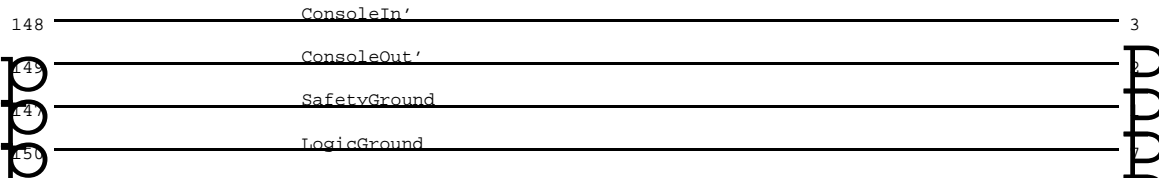
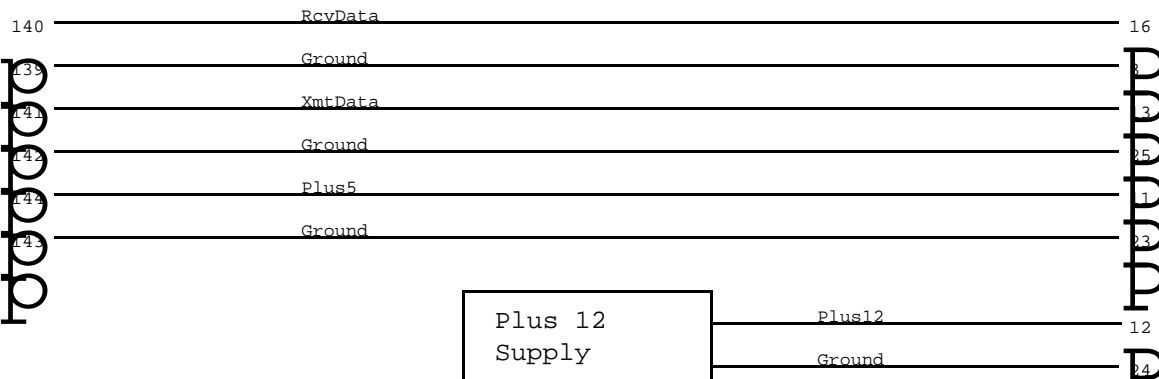
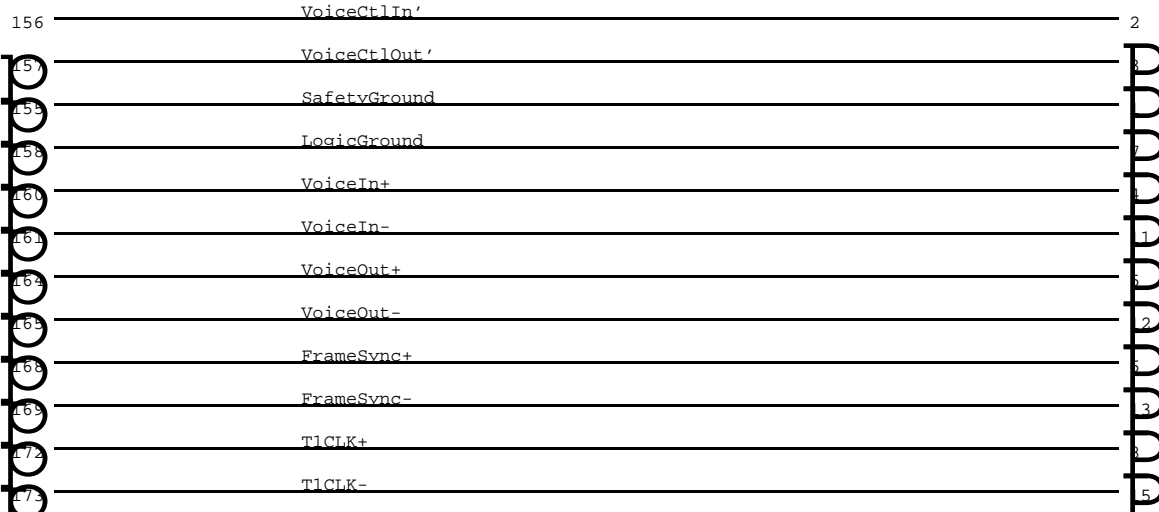

Note: leave enough slack for possible swap of pins 2 and 3

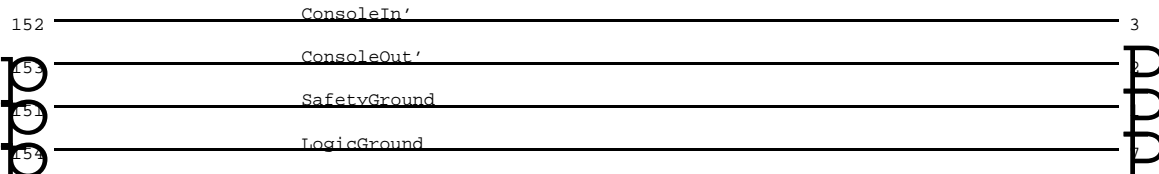

Note: leave enough slack for possible swap of pins 2 and 3



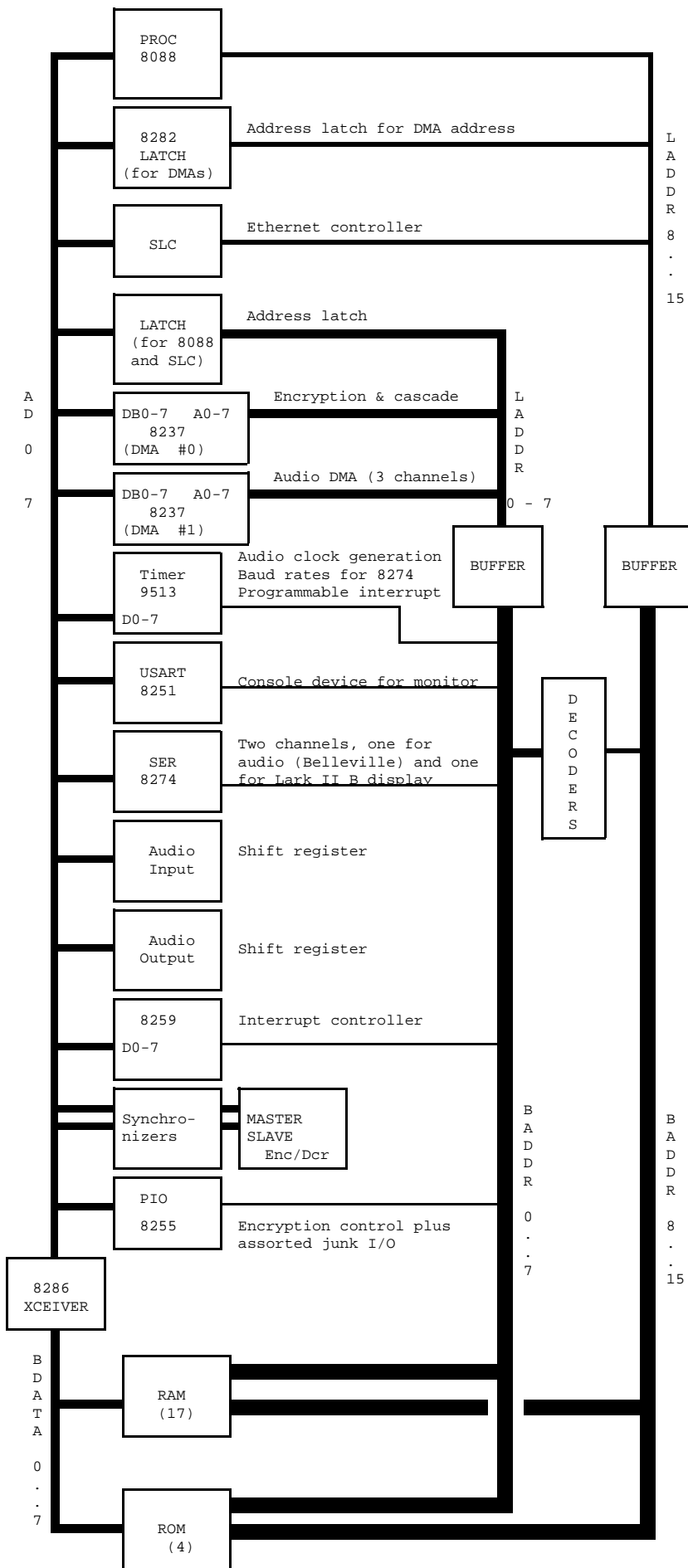

T1CLK
1.536MHZ



TSN (enable shifting)

FRAMESYNC

AUDIO TIMING

AUDININT - for 1 input and 2 output chs.

MUXING DMA/PROG ADDRESSING

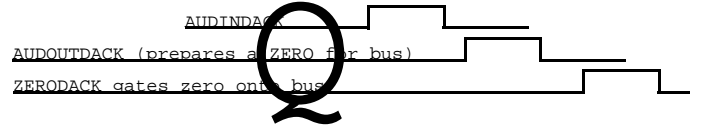
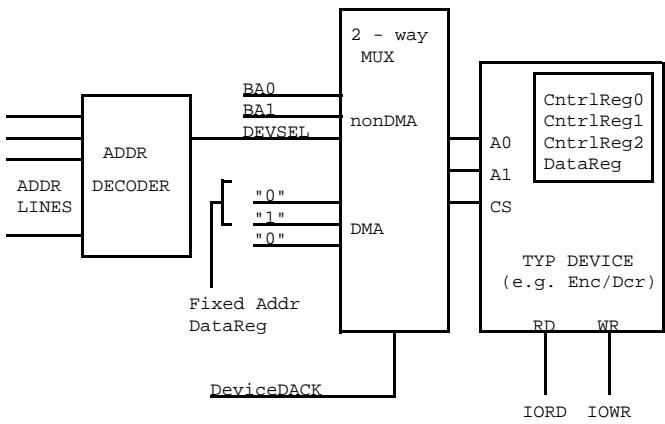

RESET

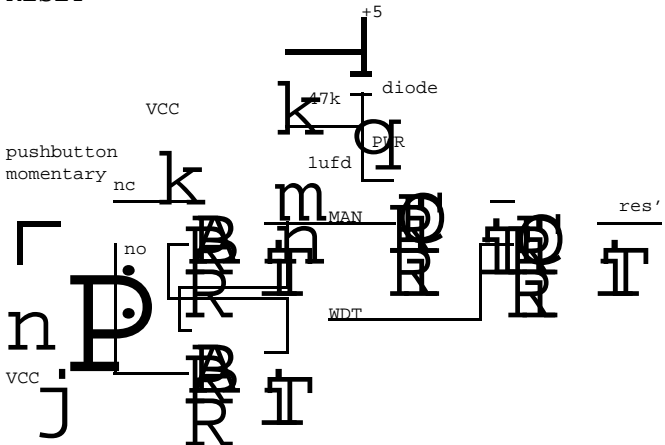

XEROX PARC	Project Voice	Reference Miscellaneous	File ETP37.sil	Designer S. Ornstein L. Stewart	Rev Ae	Date 2/07/82	Page 37
---------------	------------------	----------------------------	-------------------	---------------------------------------	-----------	-----------------	------------

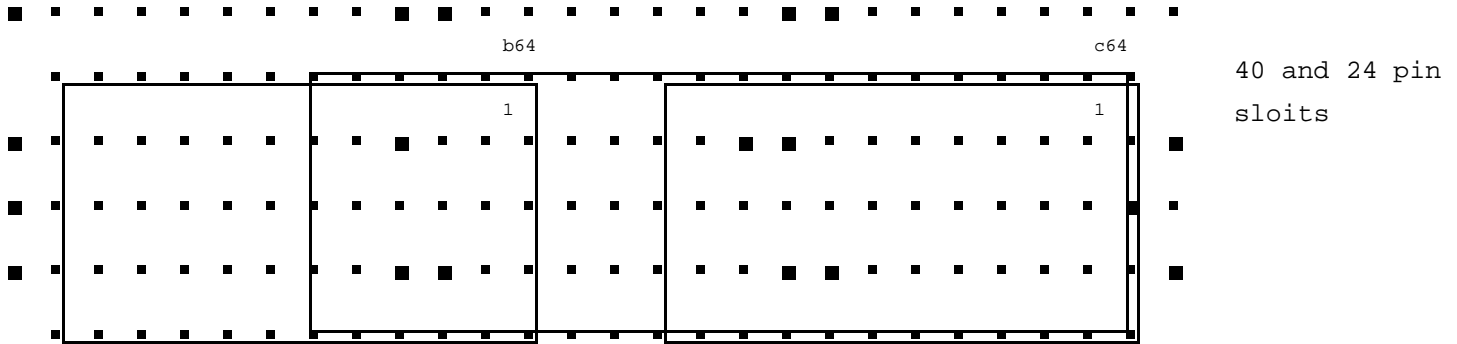

40 and 24 pin
slots

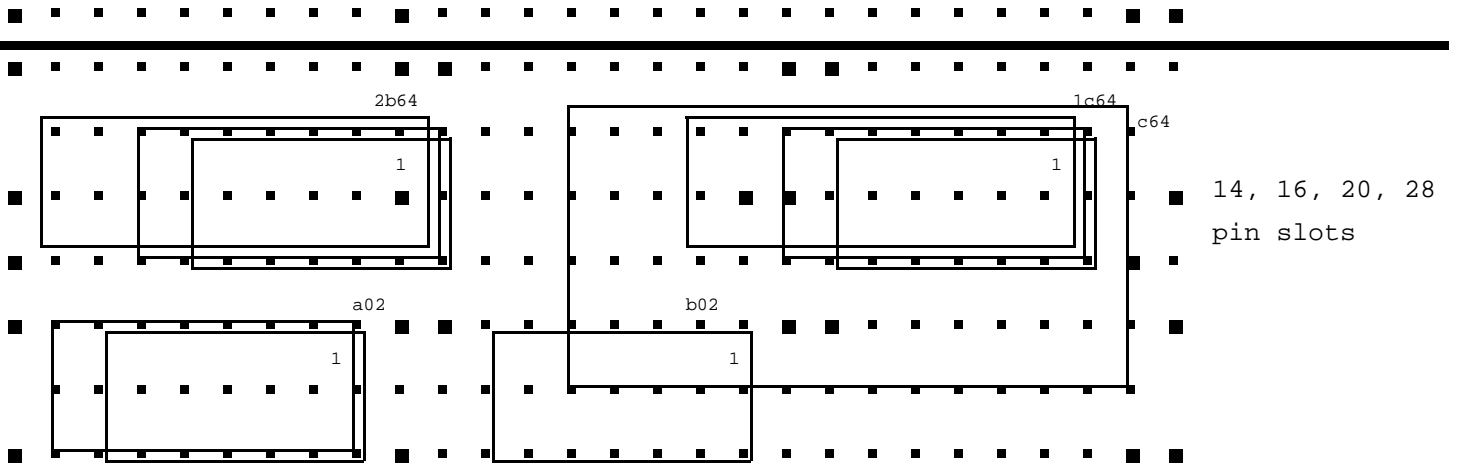

14, 16, 20, 28
pin slots

Possible chip locations, choose one

pins	columns		rows	
	left	right	top	bottom
40	c, f	k, l	64, 60, 65, 66, 61, 68	72, 69, 70, 63, 71
28	c, f	k, l	64, 60, 65, 66, 61, 68	72, 69, 70, 63, 71
24	b, c, e, f	h, i, k, l	64, 60, 65, 66, 61, 68	72, 69, 70, 63, 71
20	2b, 1c, 2e, 1f	2h, 1i, 2k, 1l	64, 60, 65, 66, 61, 68	72, 69, 70, 63, 71
16	2b, 1c, 2e, 1f	2h, 1i, 2k, 1l	64, 60, 65, 66, 61, 68	72, 69, 70, 63, 71
	a, d	g, j	02, 04, 06, 08, 10, 14	16, 18, 20, 22, 24
14	2b, 1c, 2e, 1f	2h, 1i, 2k, 1l	64, 60, 65, 66, 61, 68	72, 69, 70, 63, 71
	a, b, d, e	g, h, j, k	02, 04, 06, 08, 10, 14	16, 18, 20, 22, 24

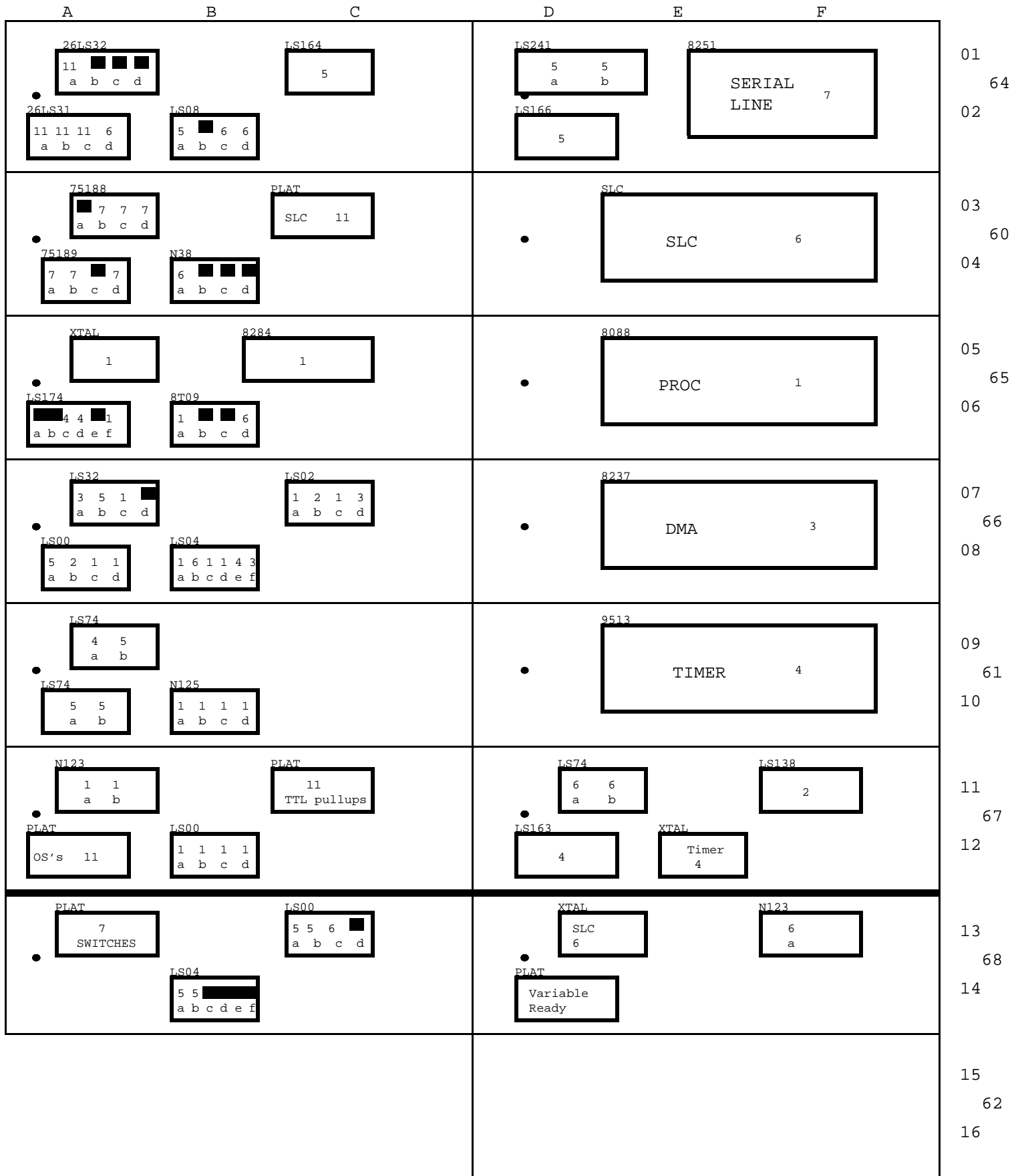

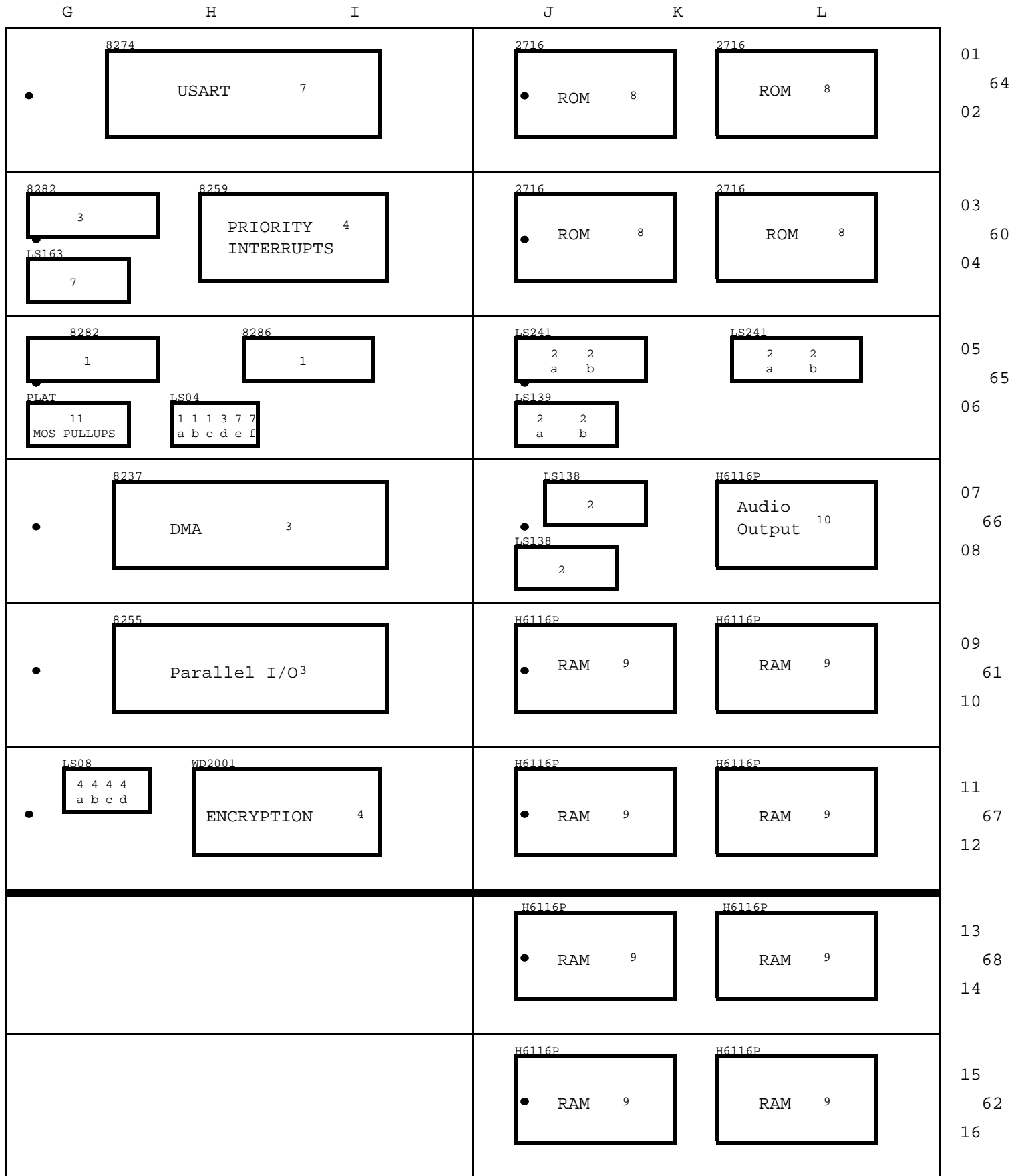

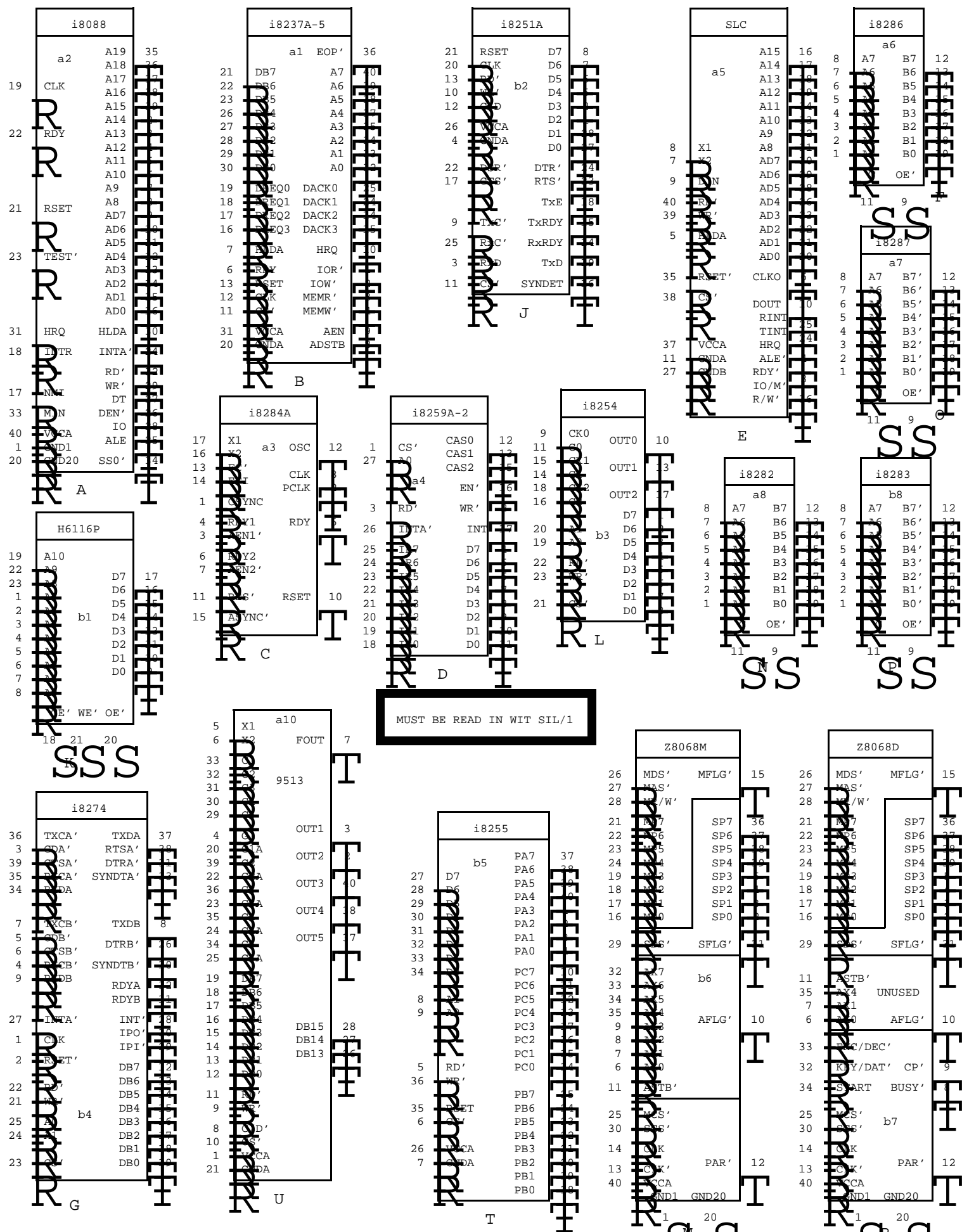

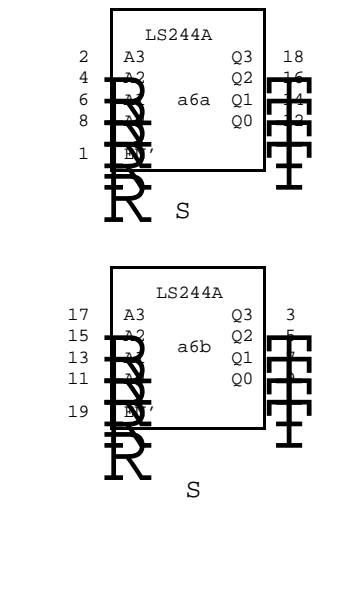
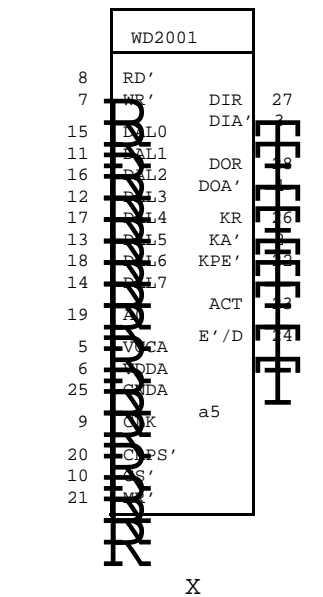
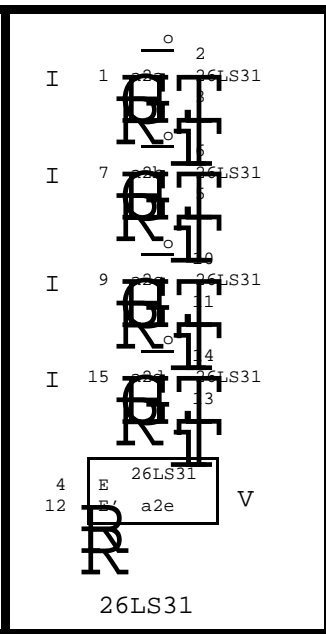
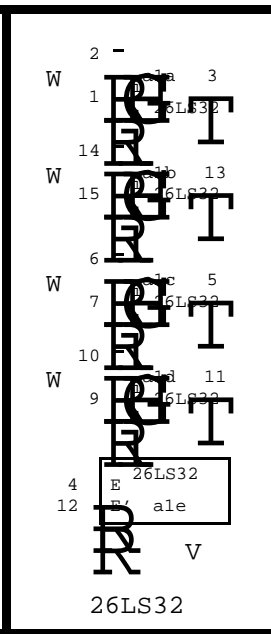
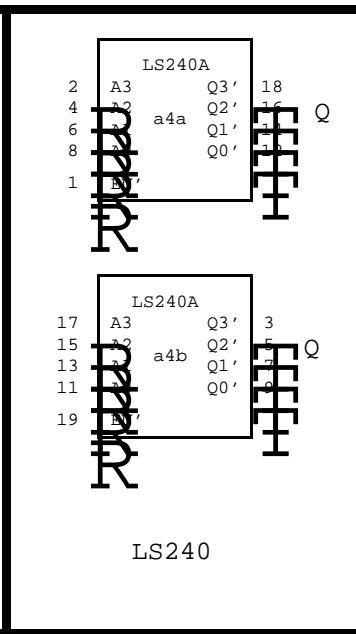
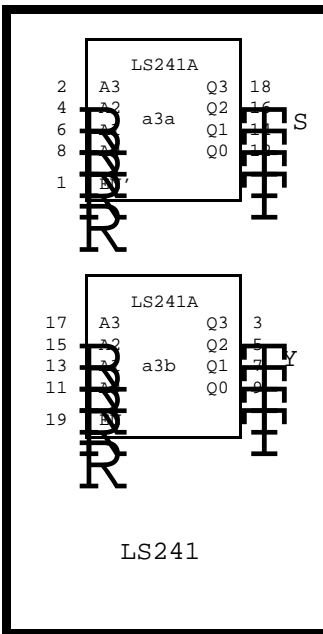

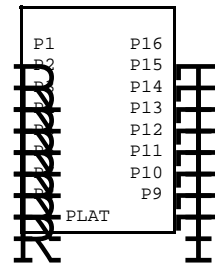
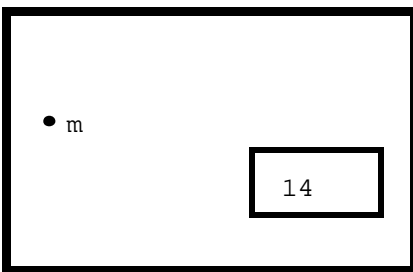
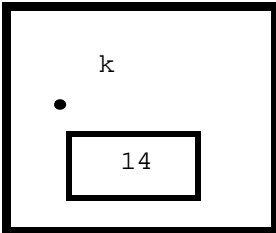
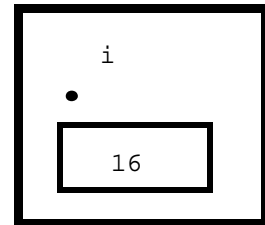
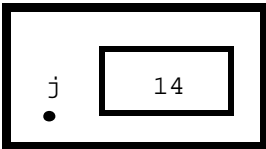
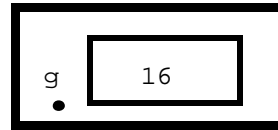
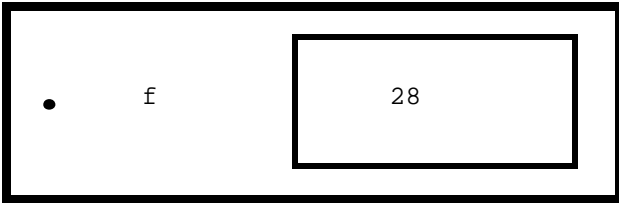
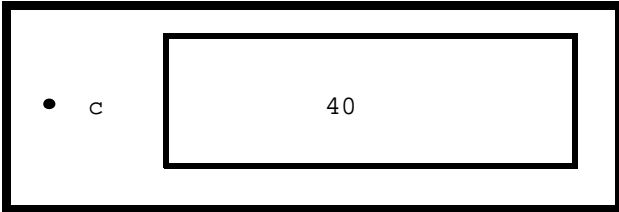
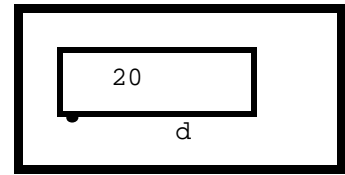
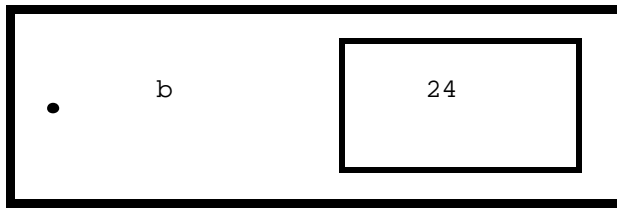
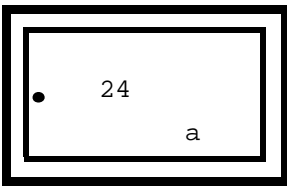

L

