

ETHERPHONE

N.B. All power goes to ELB and EAN via ETT.

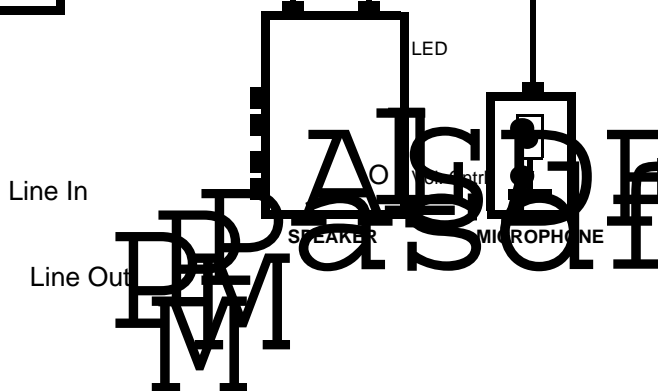

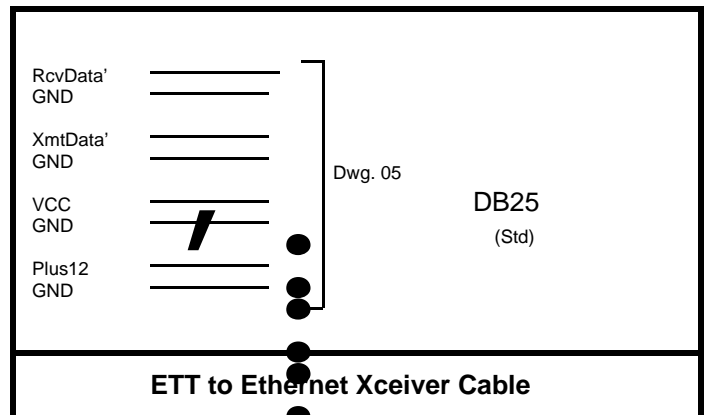
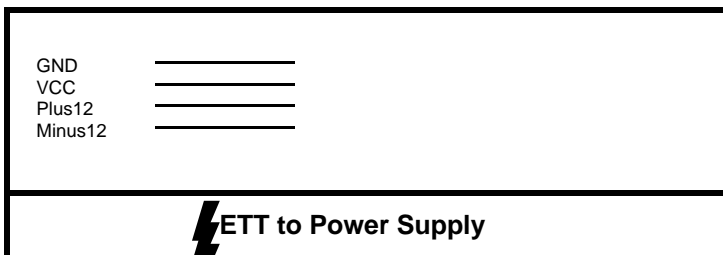
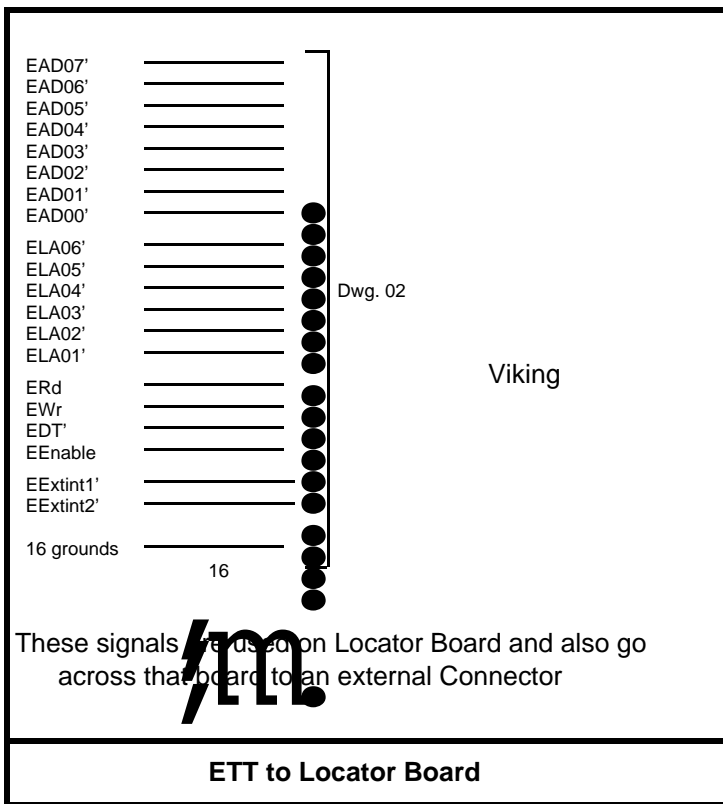
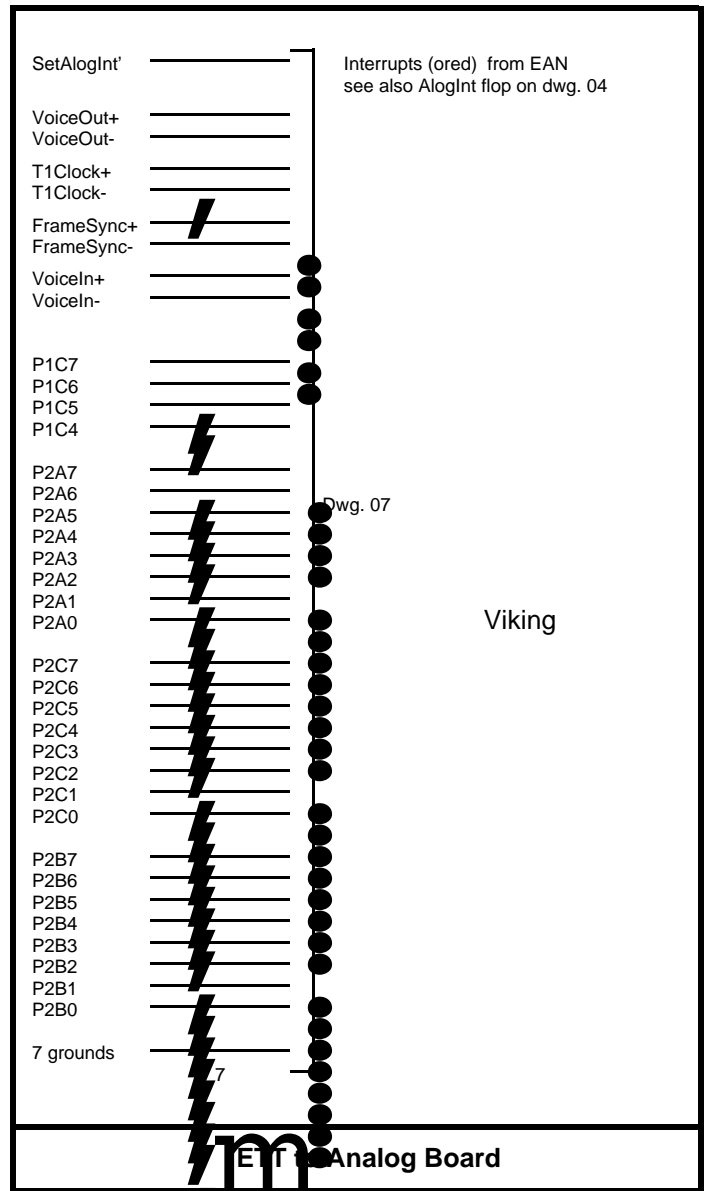
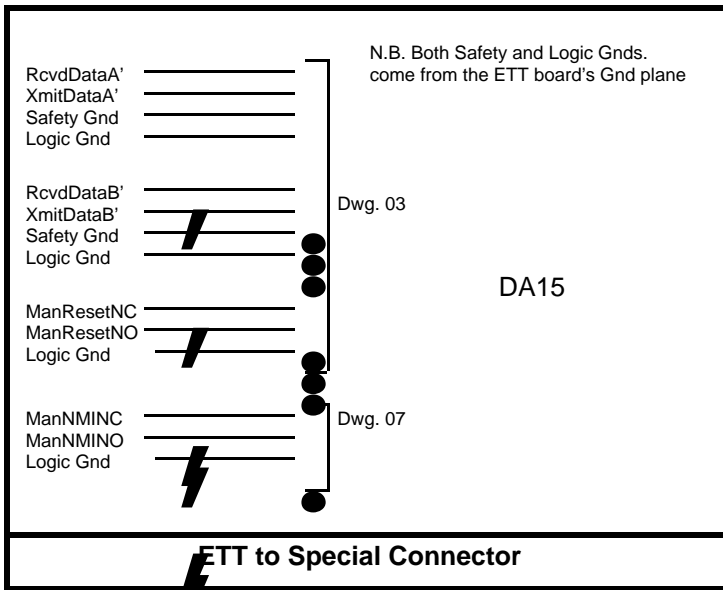

Arrows have ETT board on left

Analog and Locator Boards

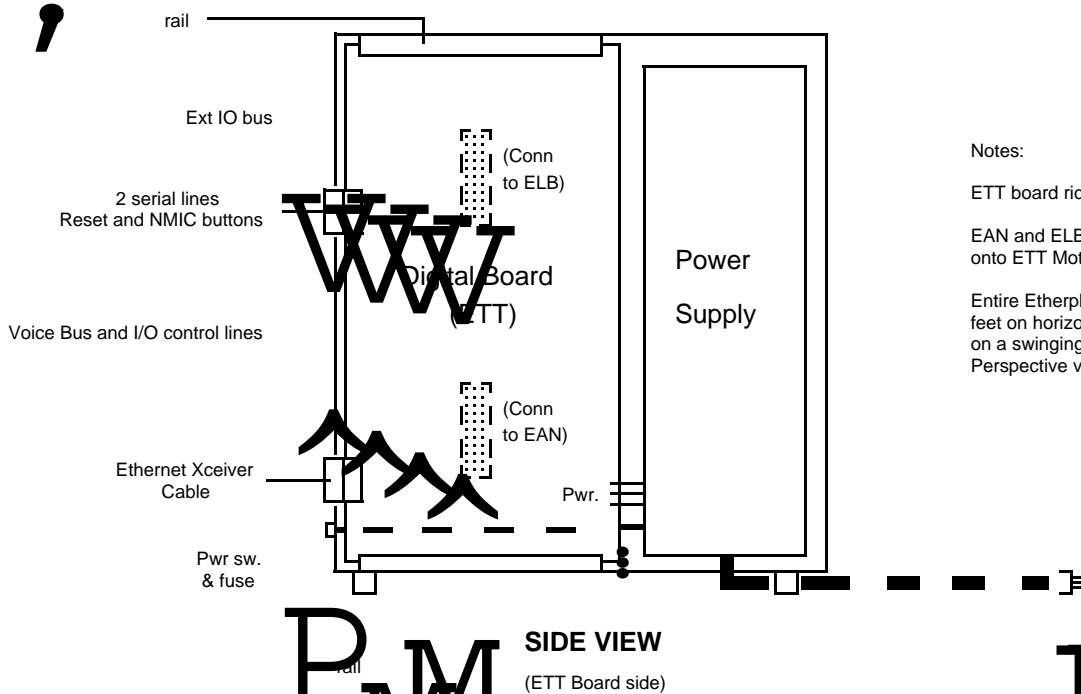
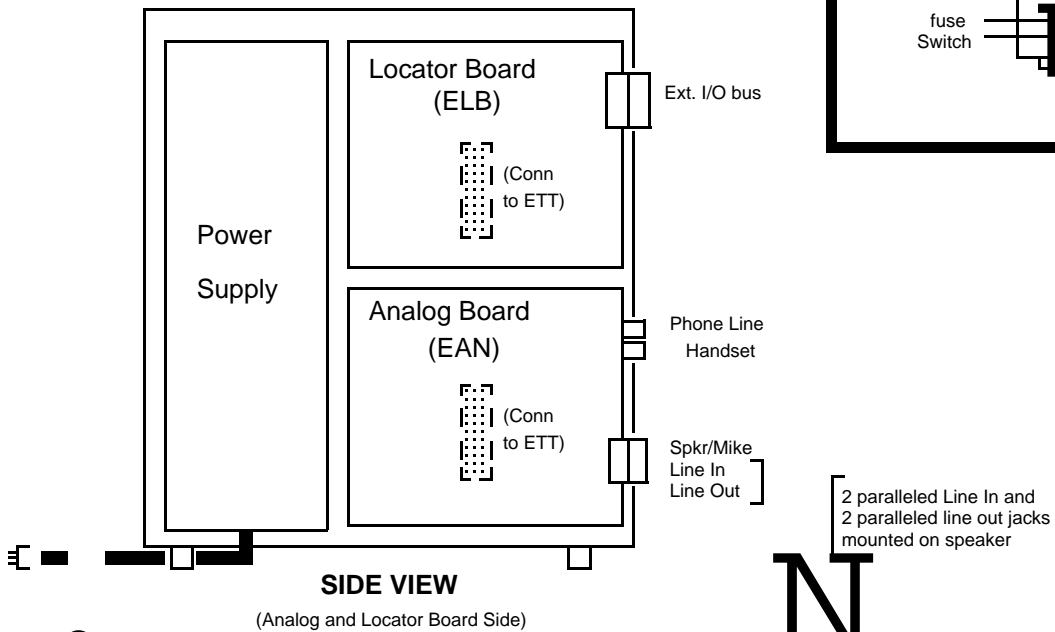
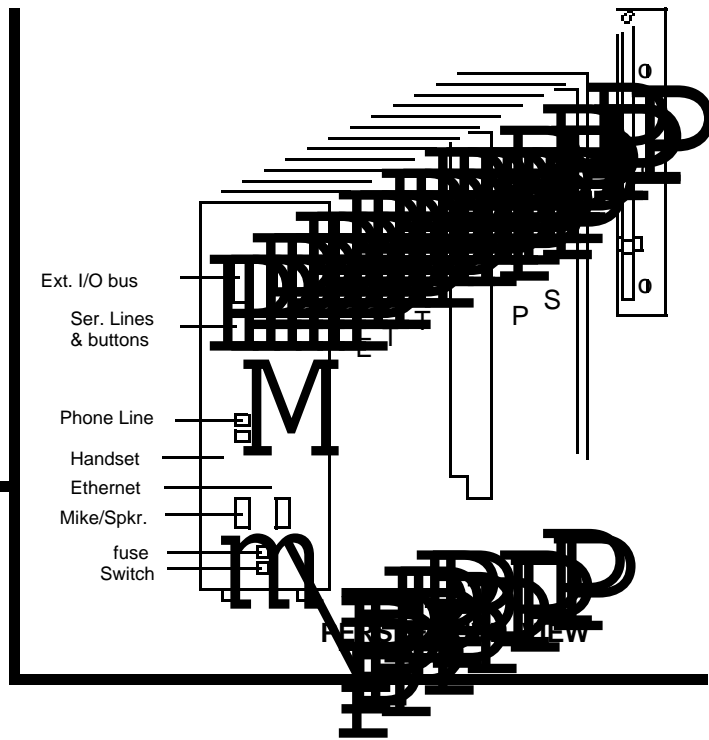
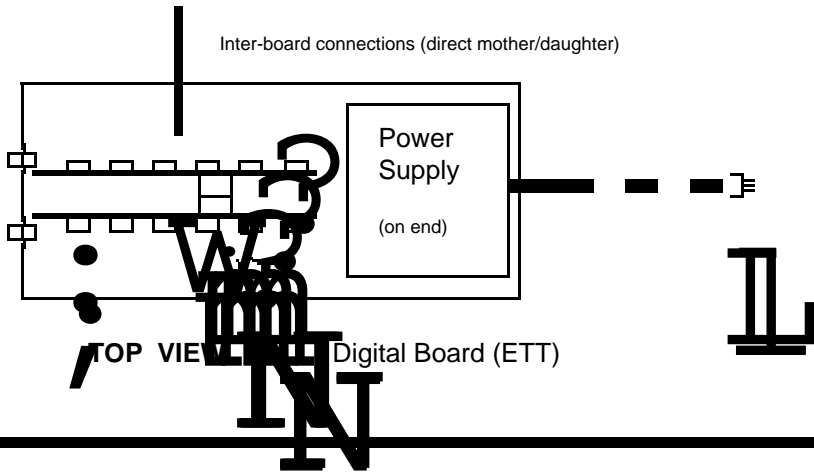

Notes:

ETT board rides in rails on frame

EAN and ELB boards mount as daughters onto ETT Motheboard

Entire Etherphone box can either sit on feet on horizontal surface or be hung on a swinging wall-mount (as shown in Perspective view).