

Figure 1: Dorado block diagram

<===<<

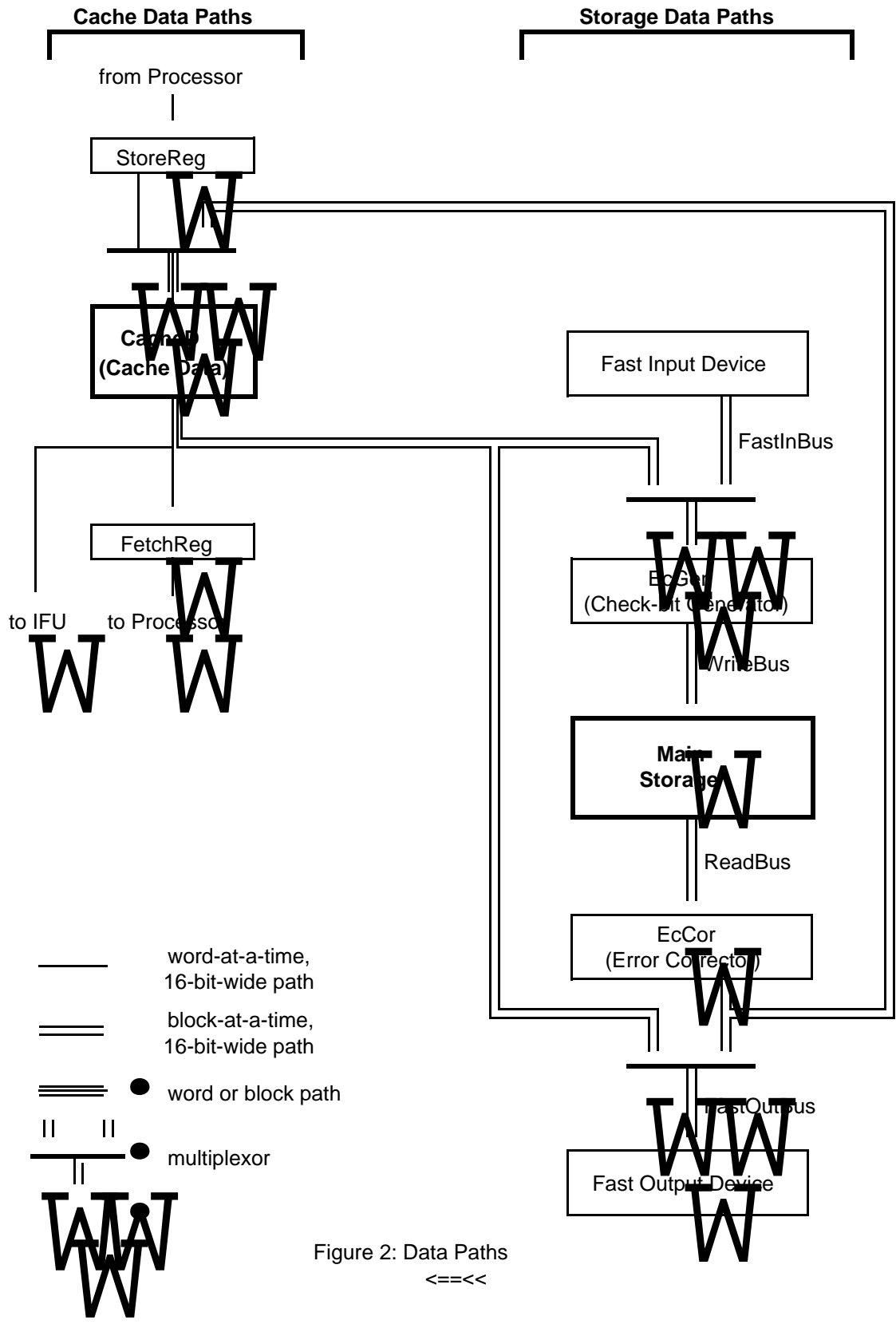

Figure 2: Data Paths
 <====>

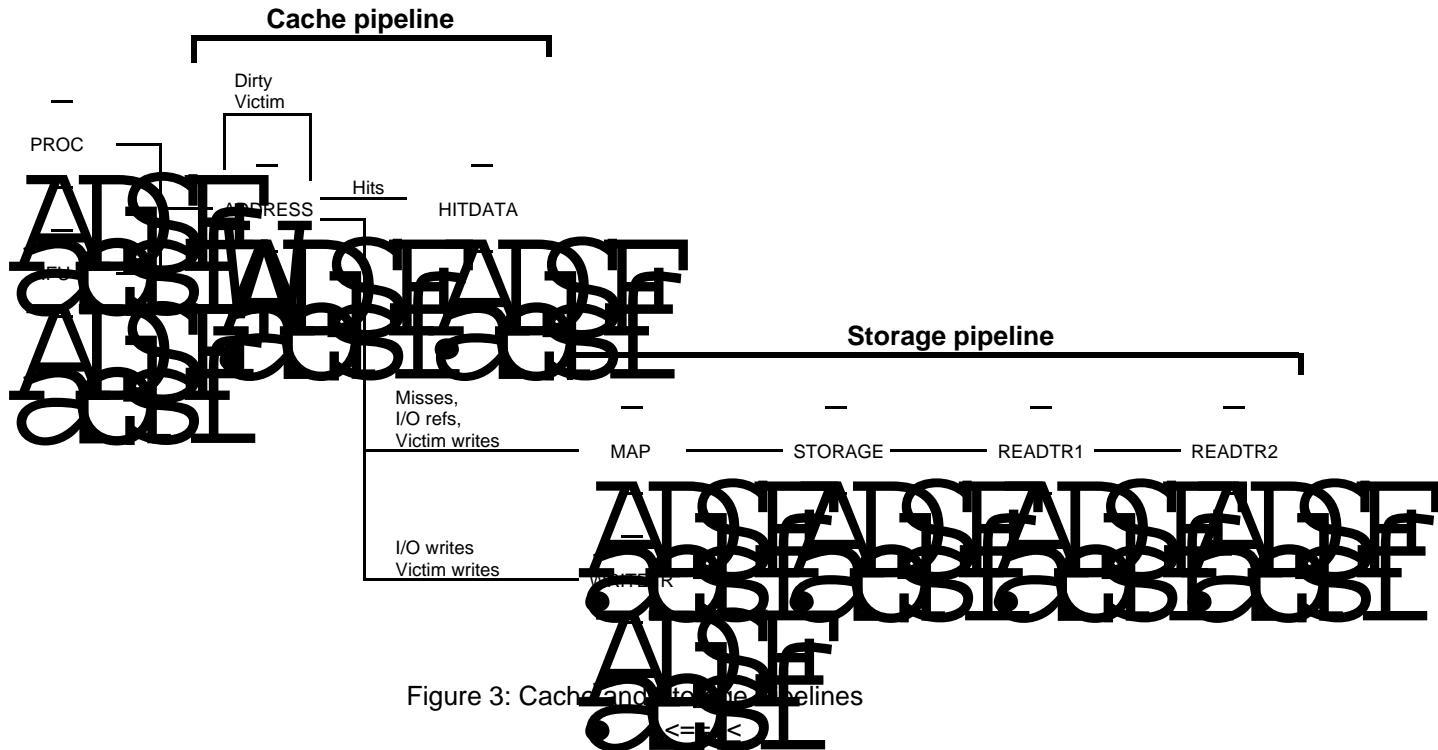
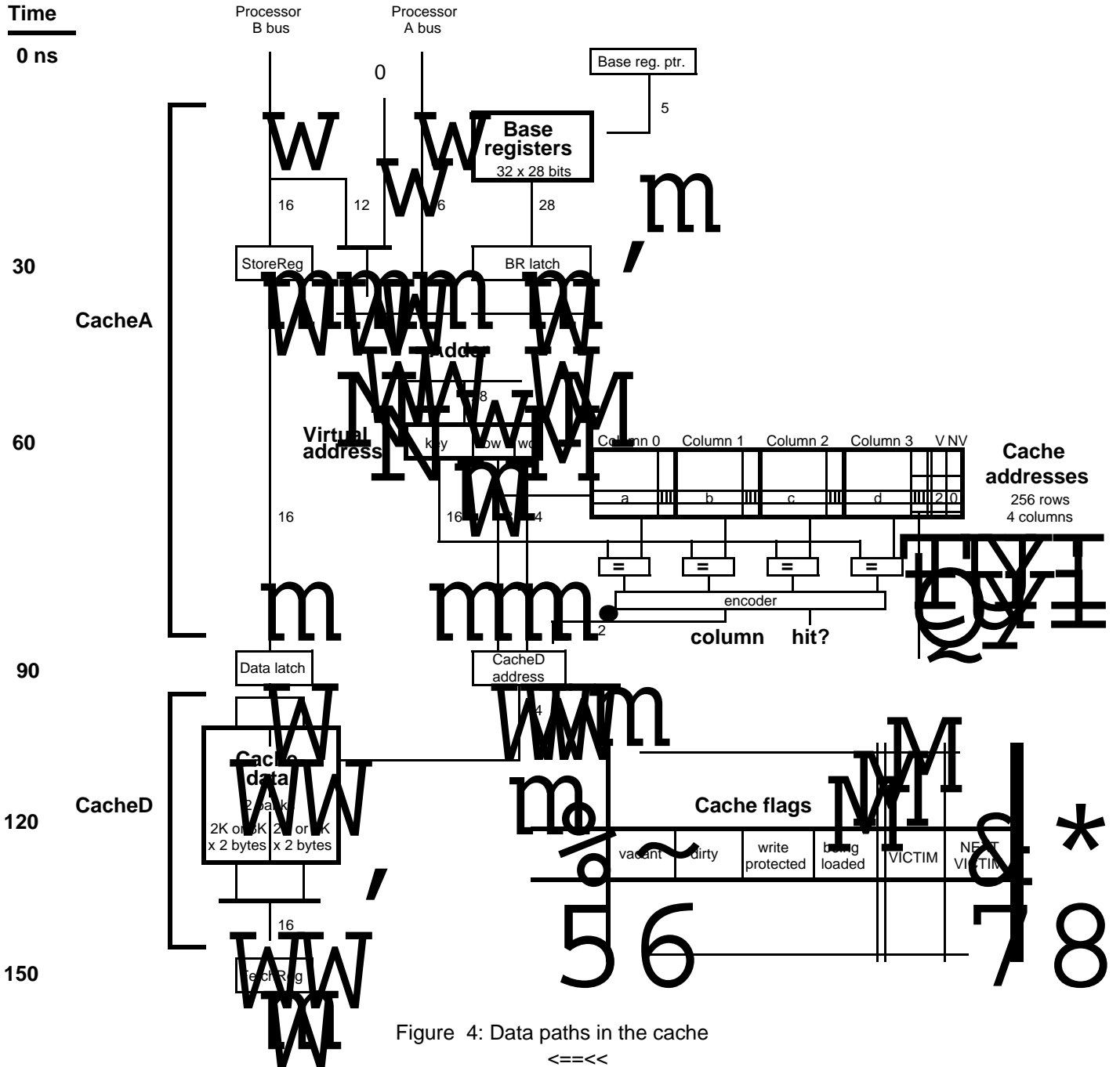
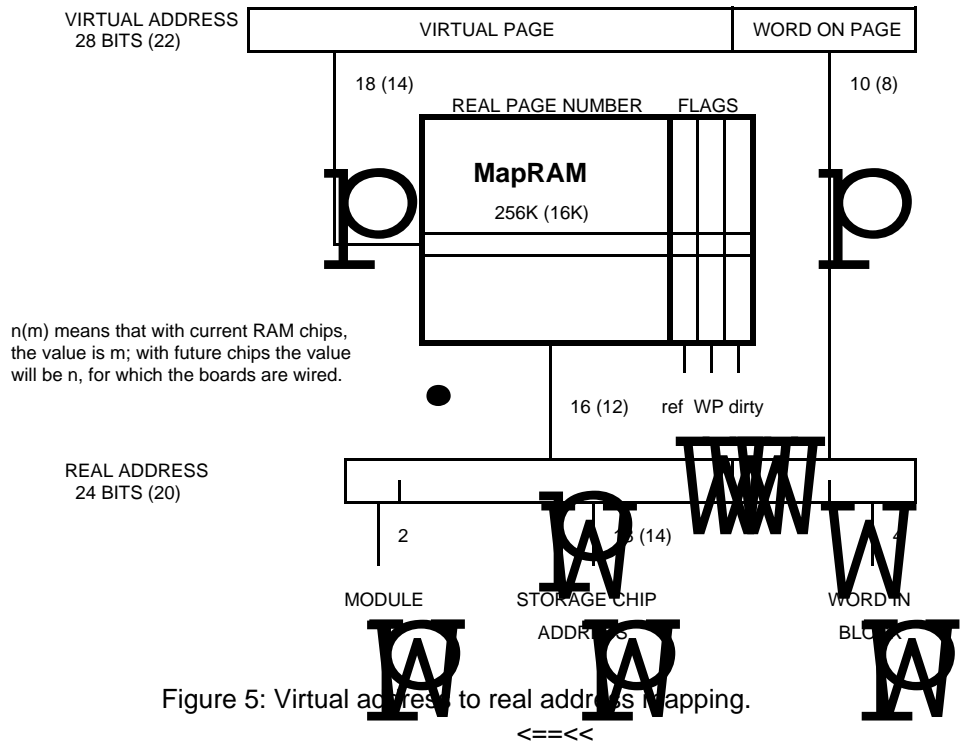

Figure 3: Cache and storage pipelines





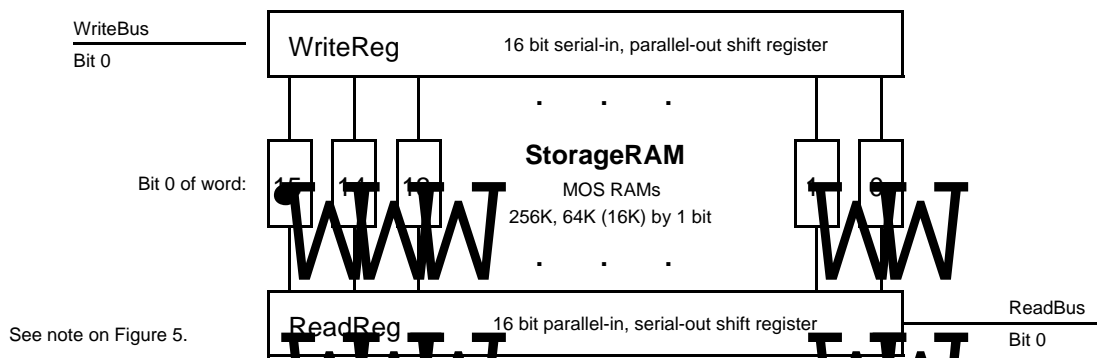

Figure 6: One bit-slice of StorageRAM and its data registers.

<==<<



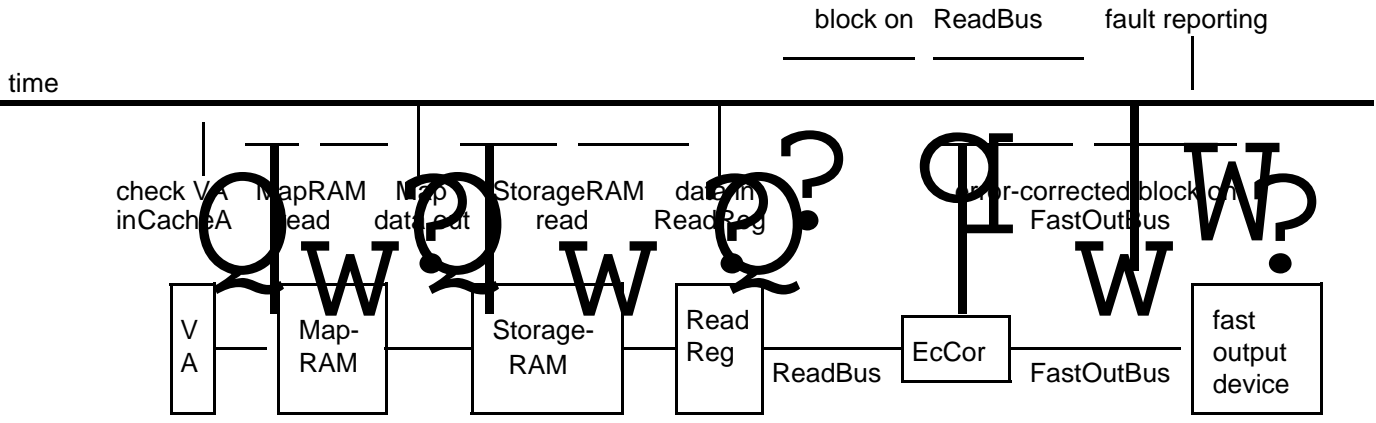
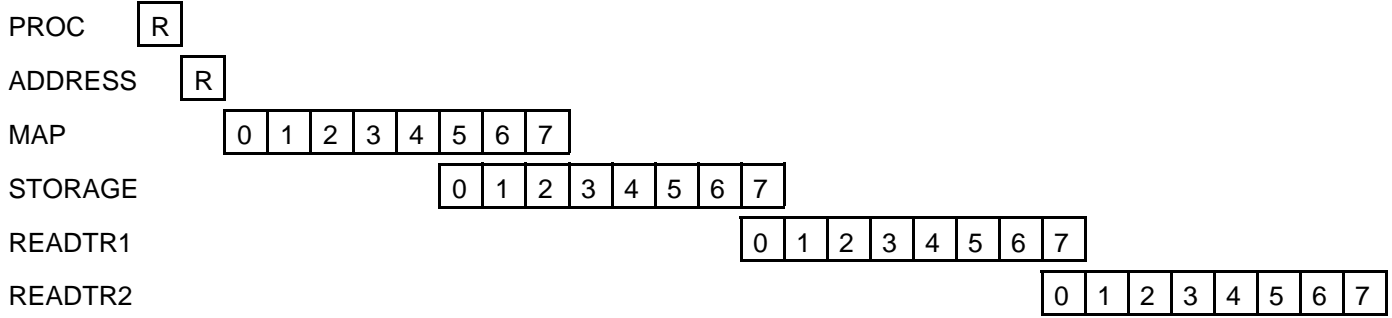

Figure 7: An I/ORead reference <====<

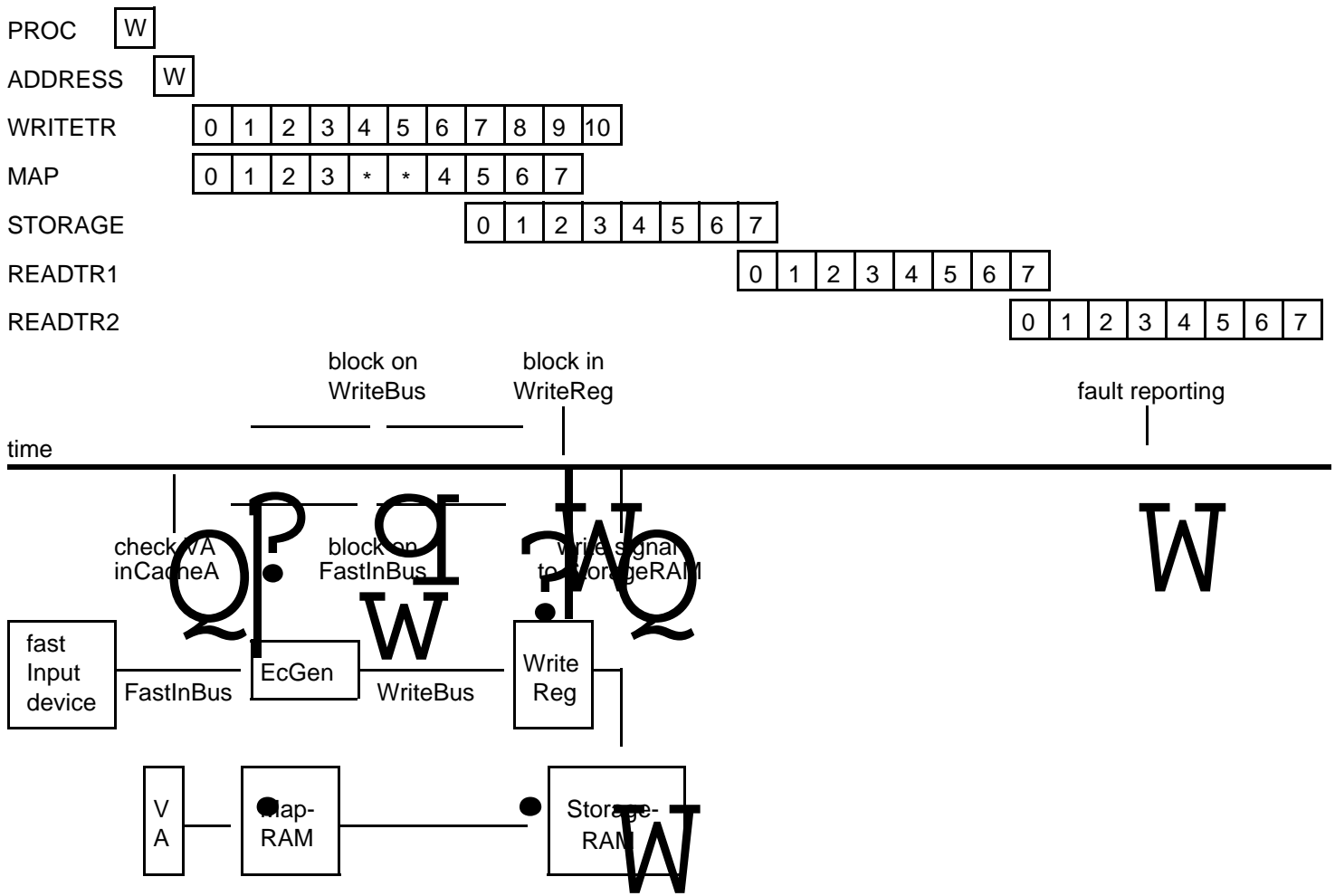

Figure 8: An I/O write reference

<====<

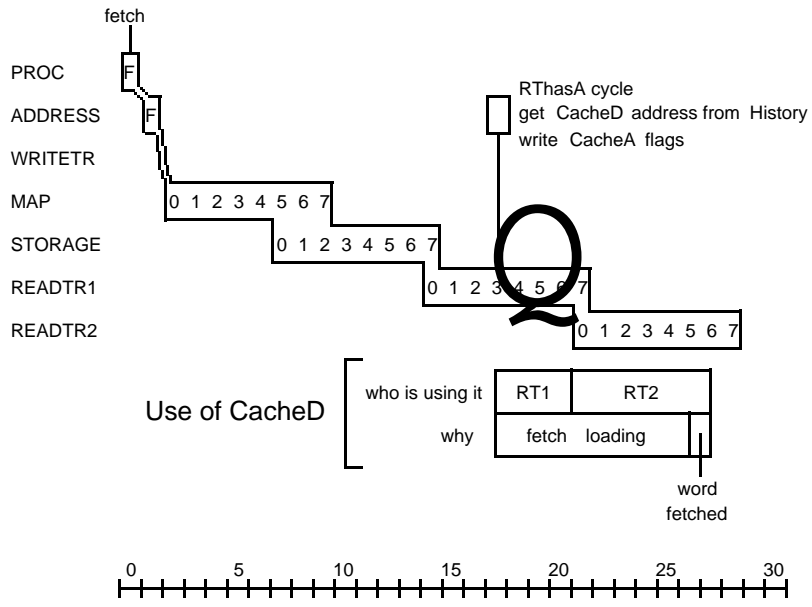

Figure 9: A clean miss

<==<<

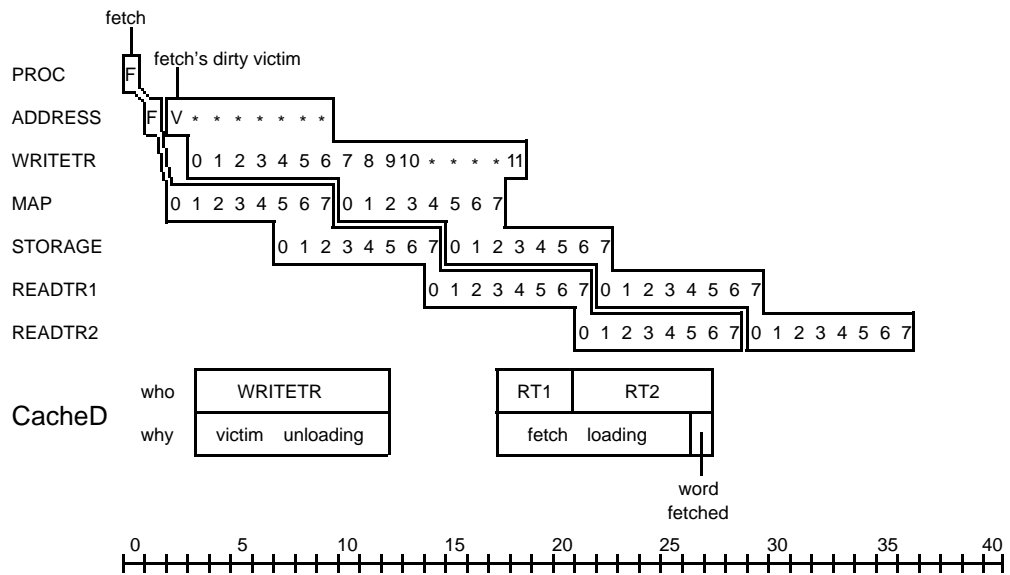

Figure 10: A dirty miss

<===<<

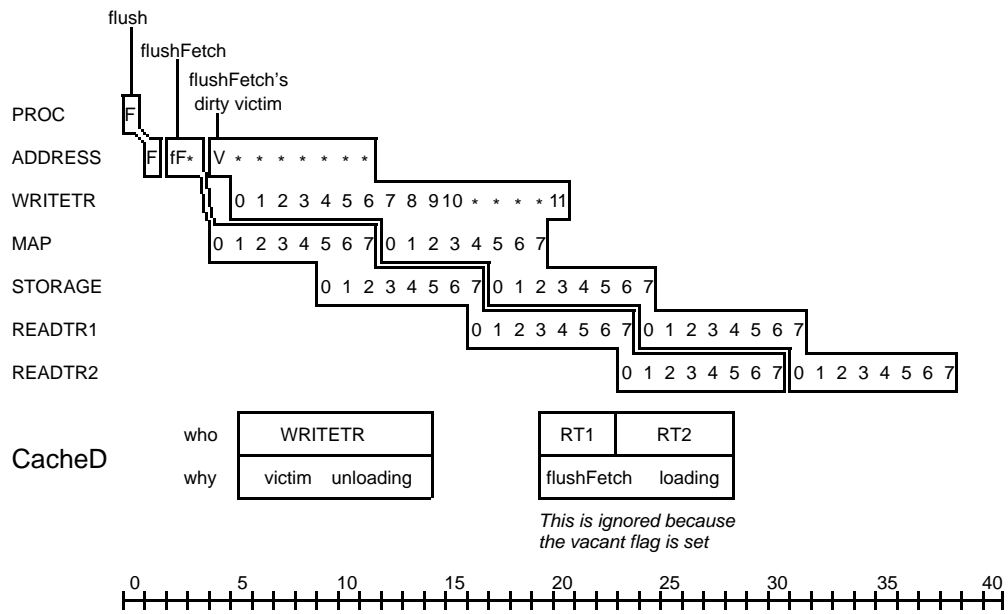

Figure 11: A dirty flush

<==<<

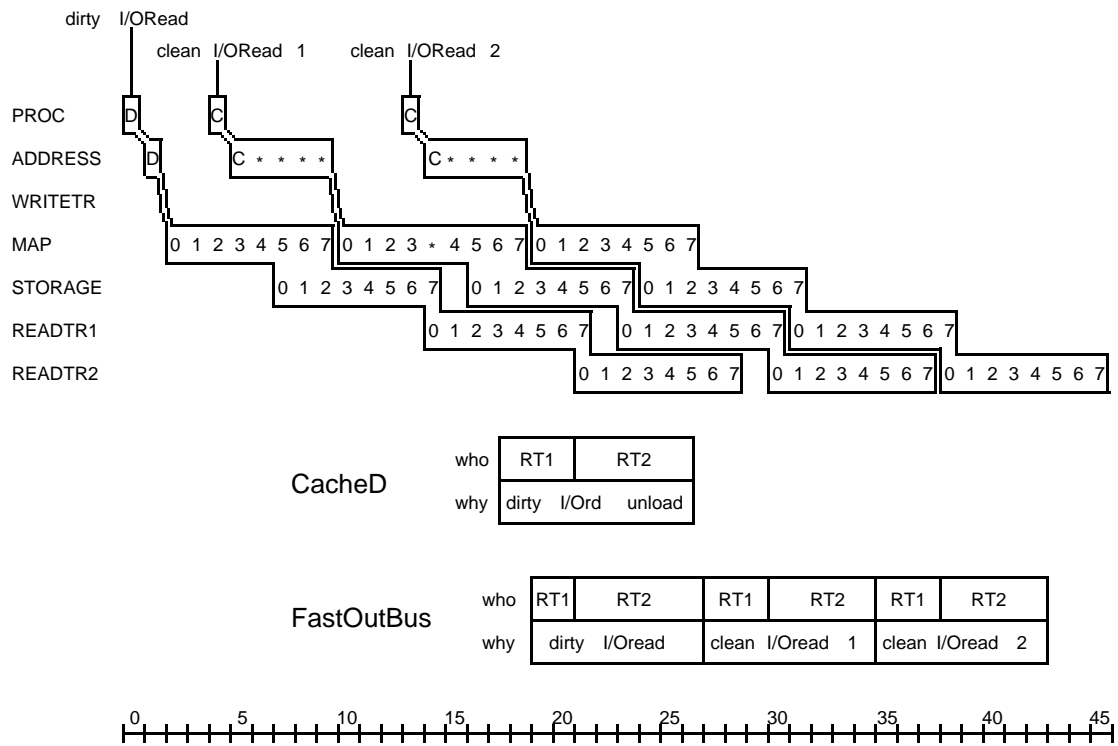

Figure 12: A dirty I/O read and two clean ones

<===<<

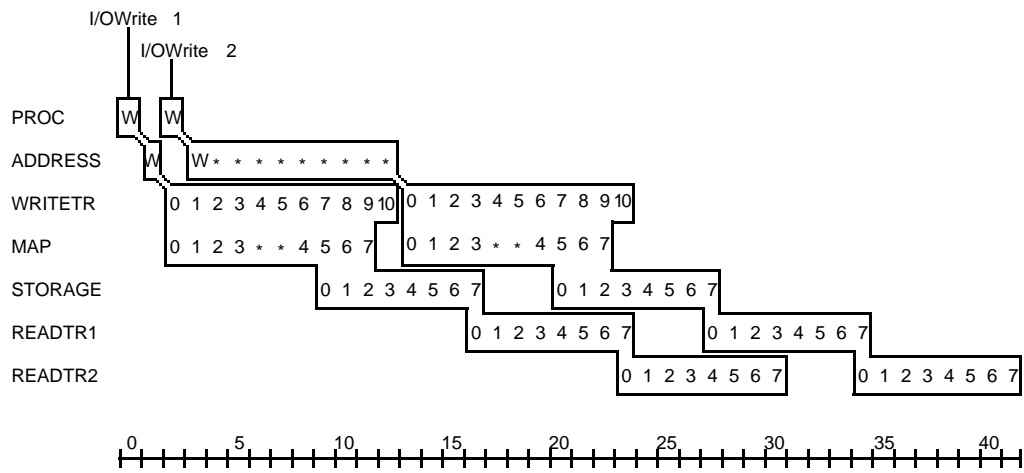

Figure 13: Two I/Owrites

<==<<

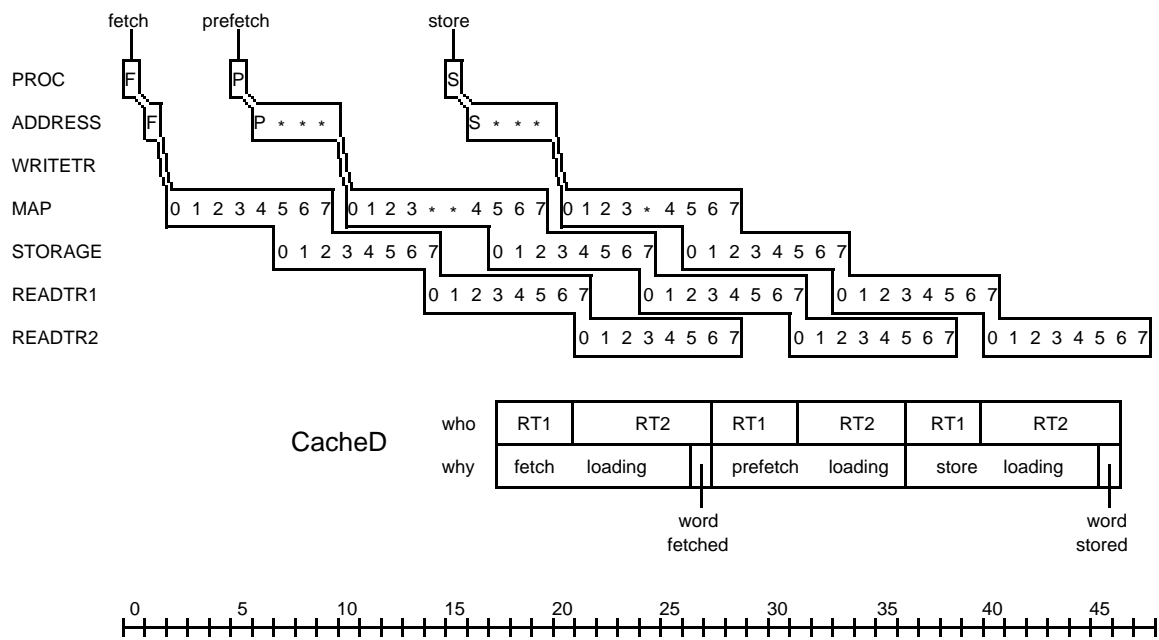

Figure 14: Cache load conflict for CacheD
 <===<<

