

**ALTO II 64k BIT
SLOT INTERFAC E**

Table of contents

TITLE	<i>Page</i>
Wake up logic _____	0 2
Printer interface _____	0 3
F Decodes _____	0 4
A Buffer Addressing _____	0 5
A Buffer Memory _____	0 7
B Buffer Addressing _____	0 8
B Buffer Memory _____	1 0
Shifter _____	1 1
Shifter Control _____	1 2
Buffer Control _____	1 3
Alto Bus Interface _____	1 4
Microprocessor, Bus Buffers, etc. _____	1 5

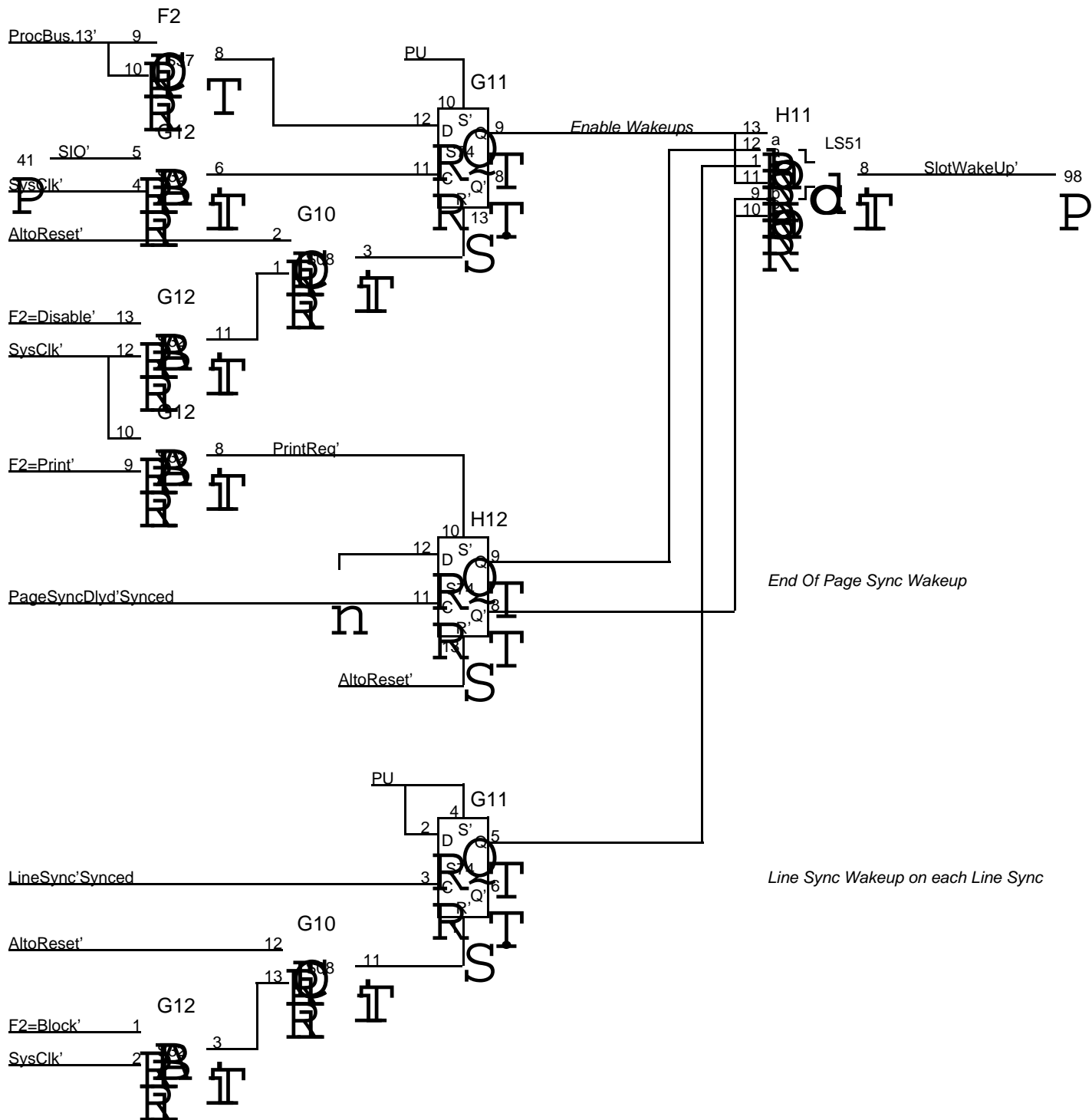

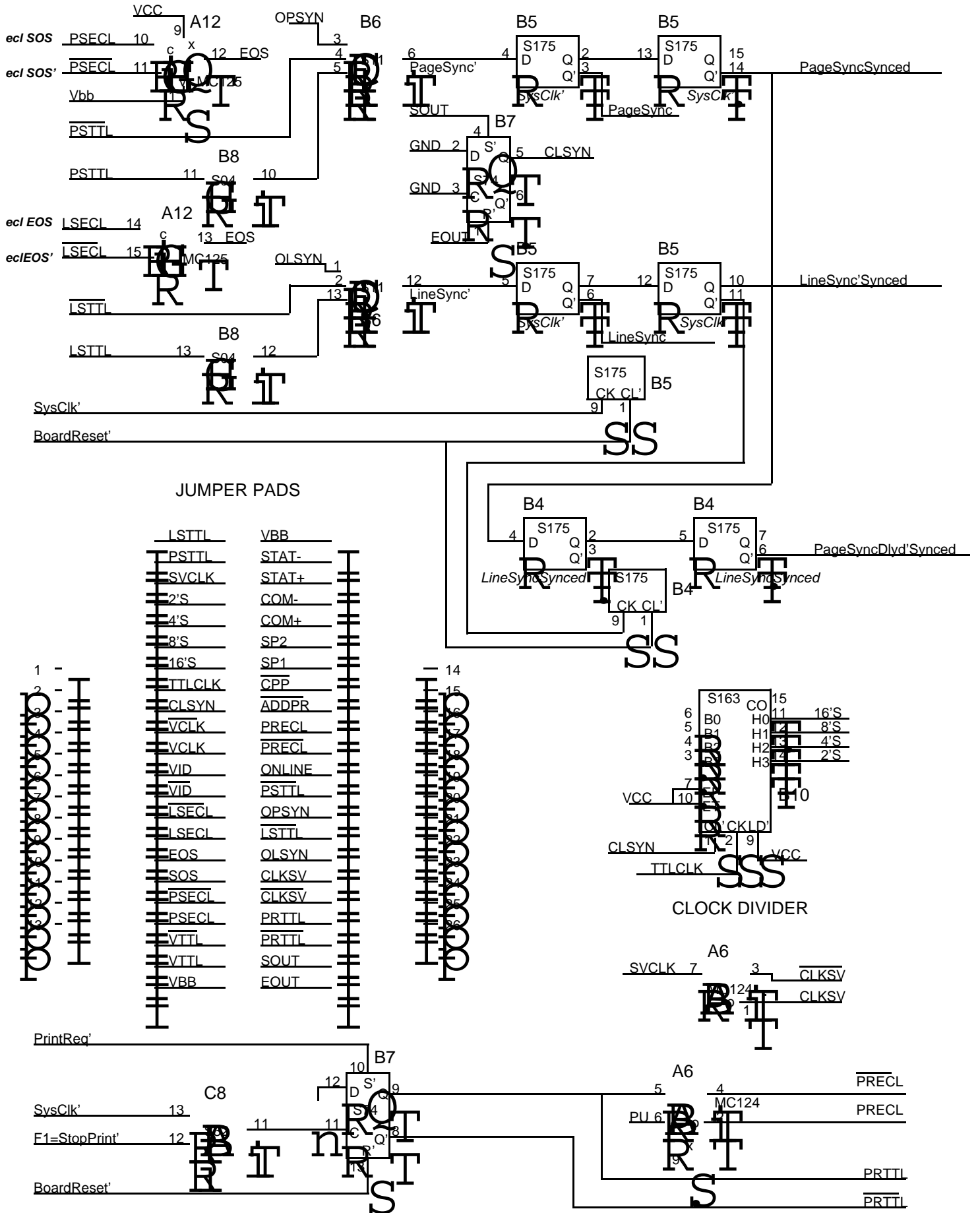

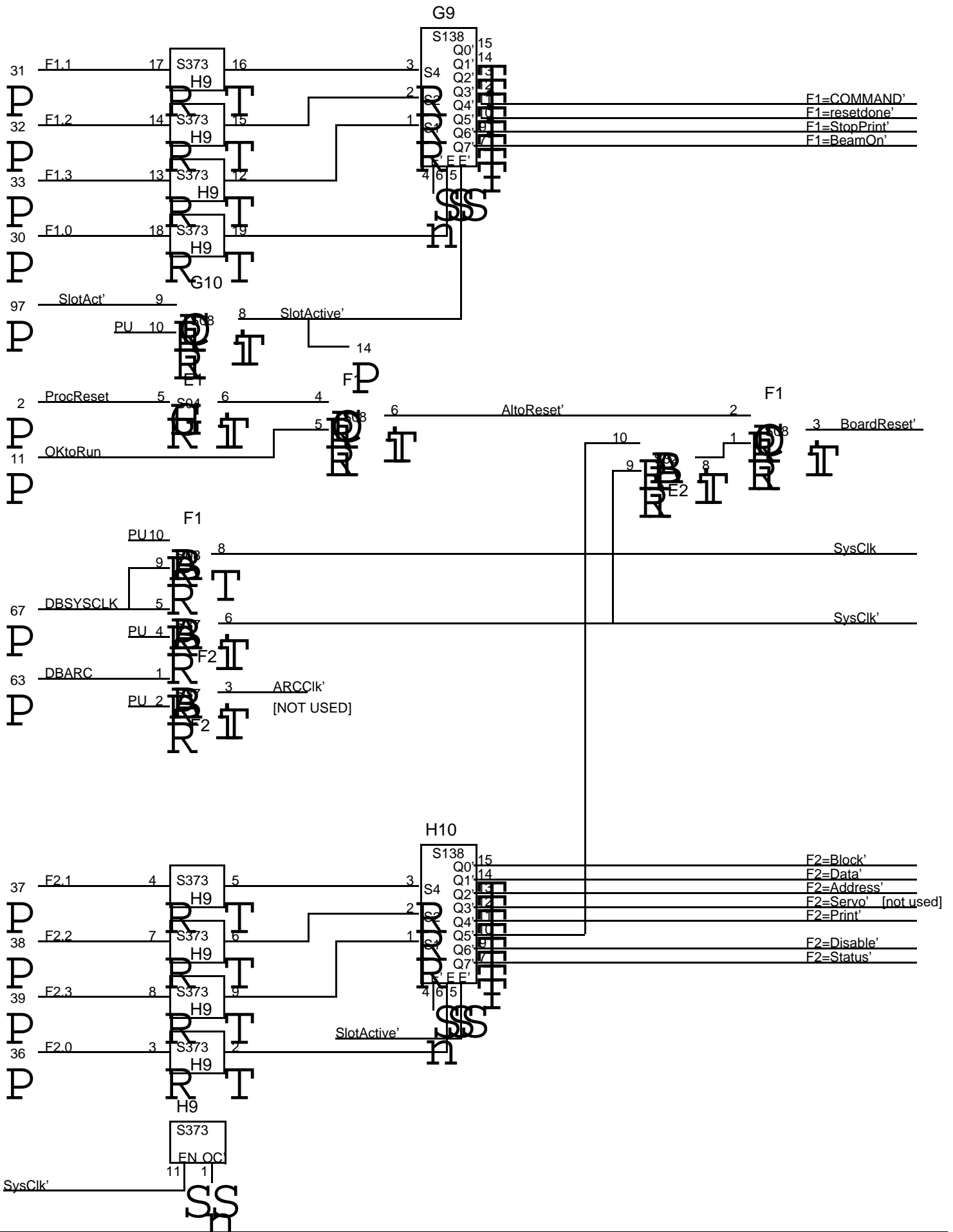

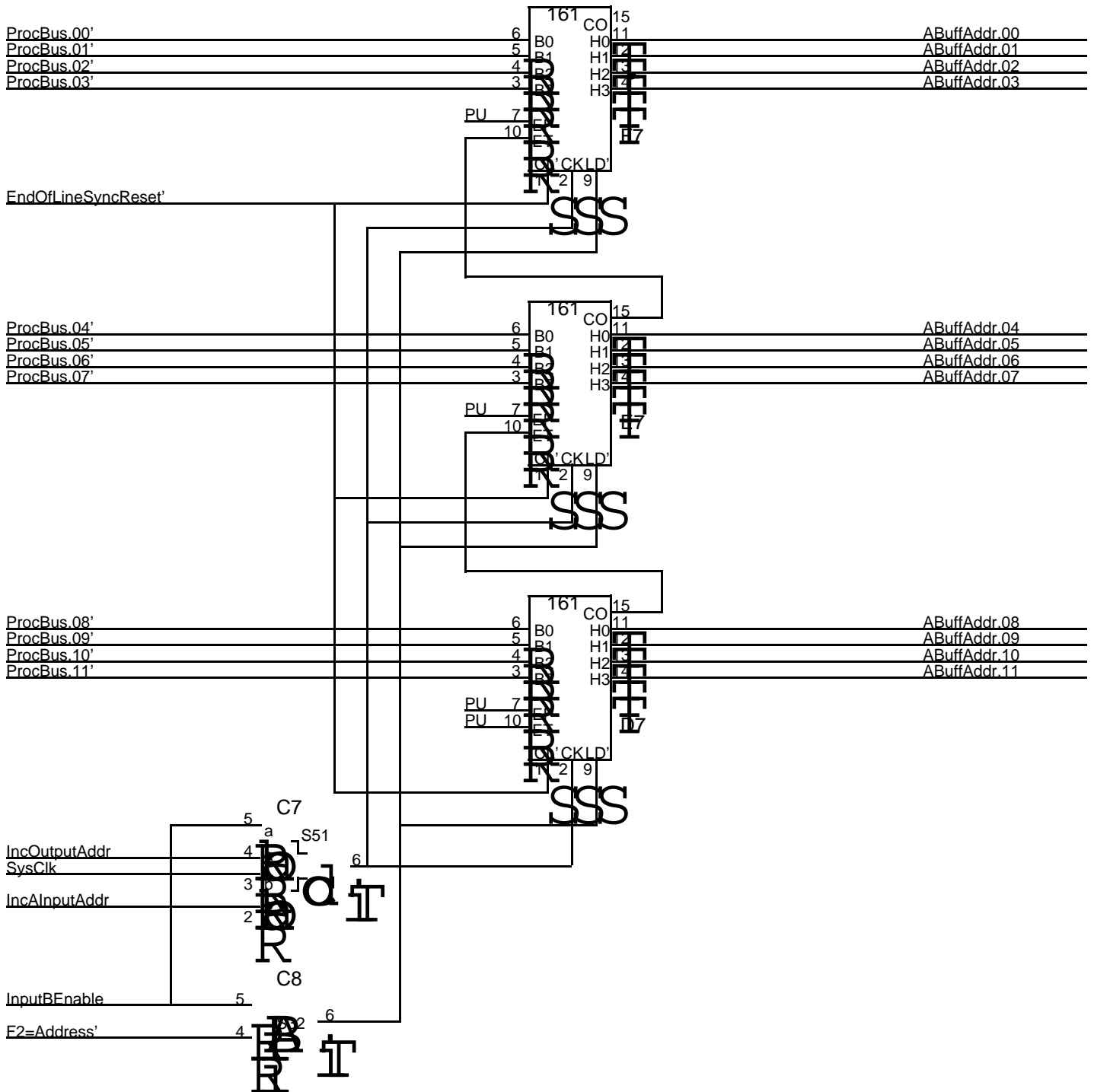

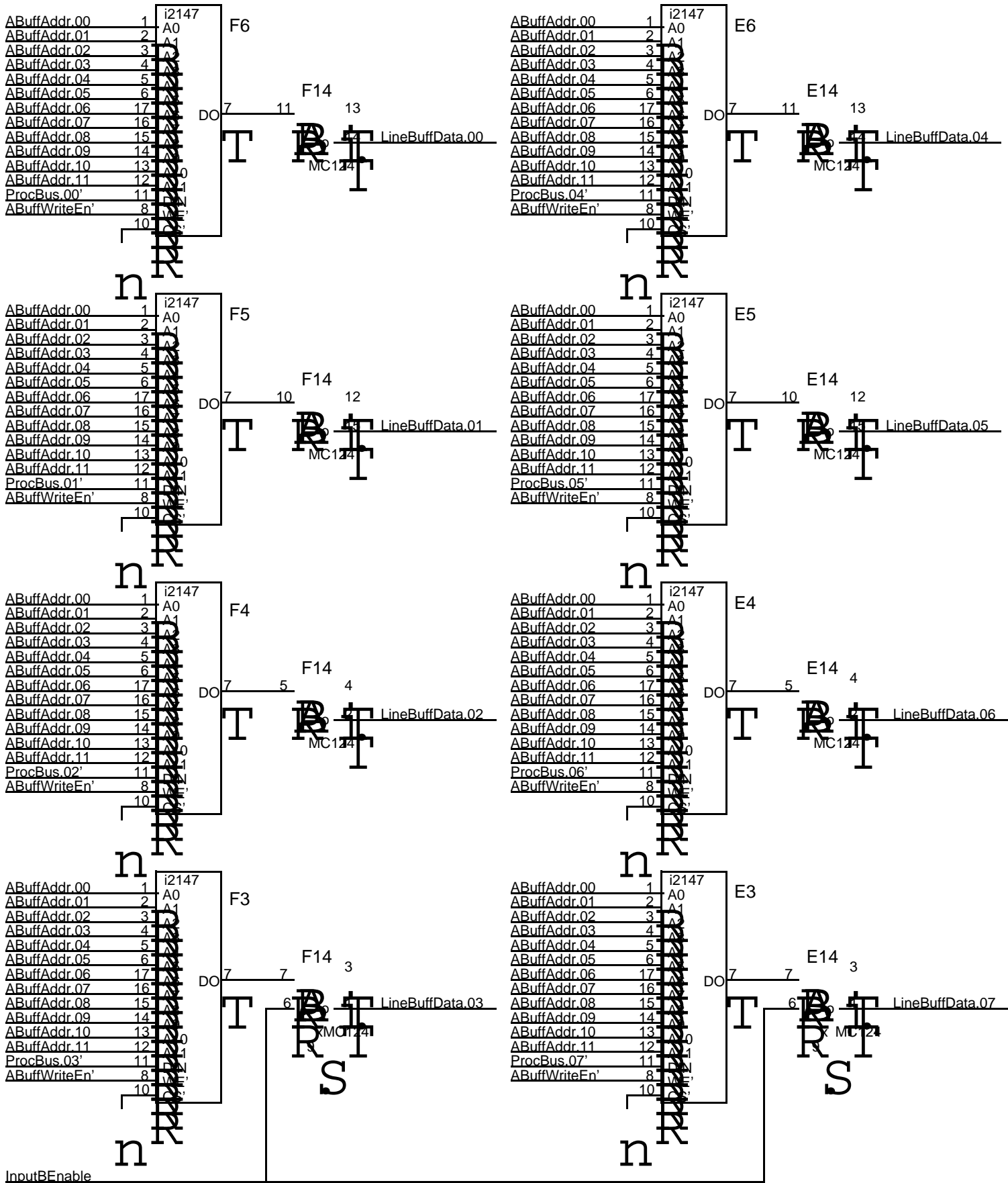

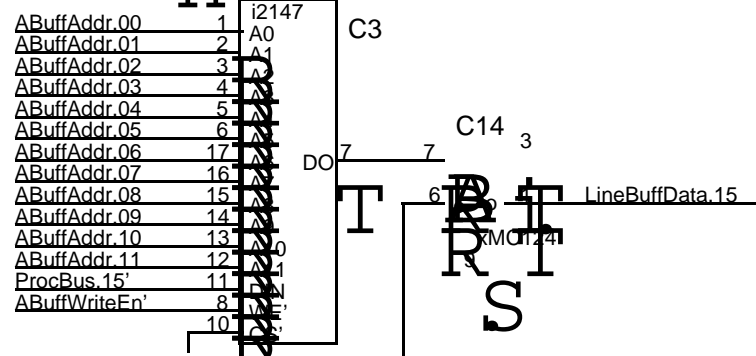
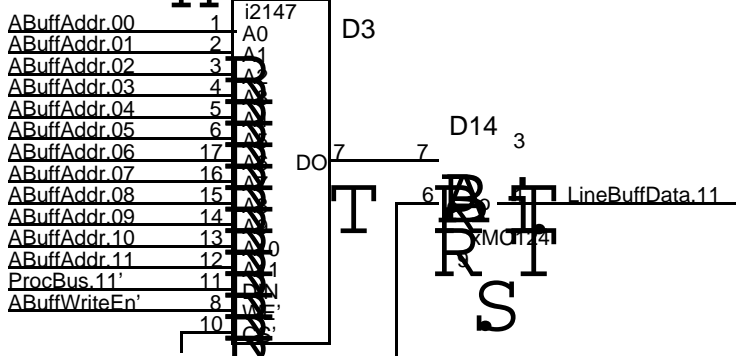
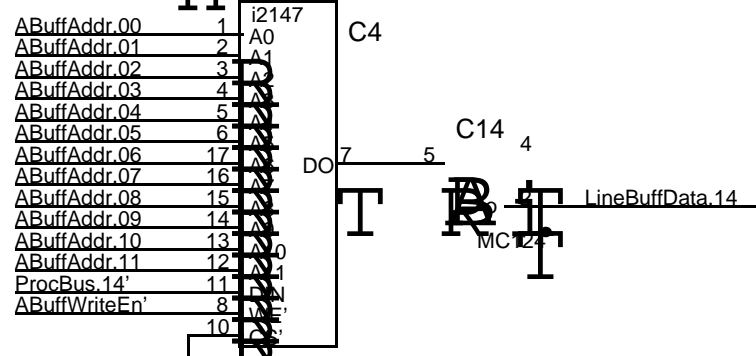
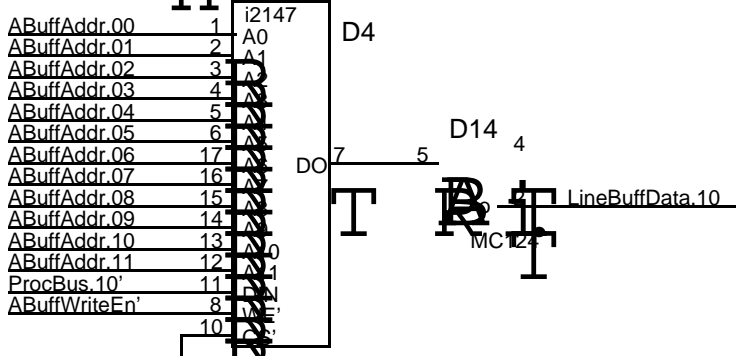
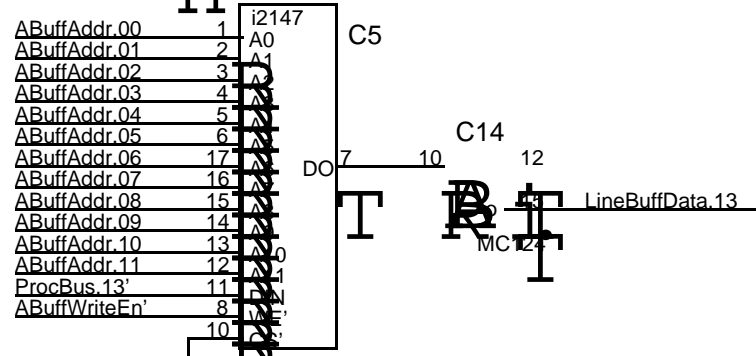
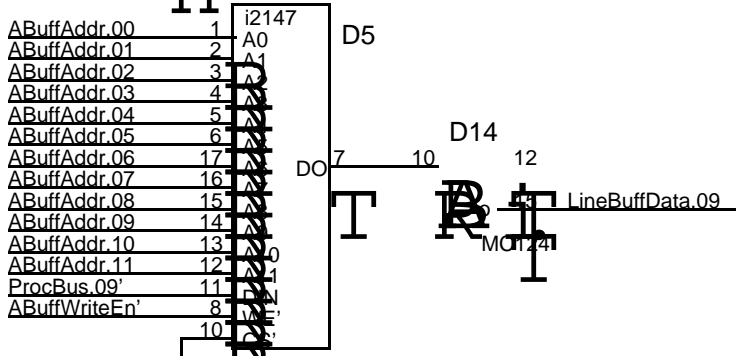
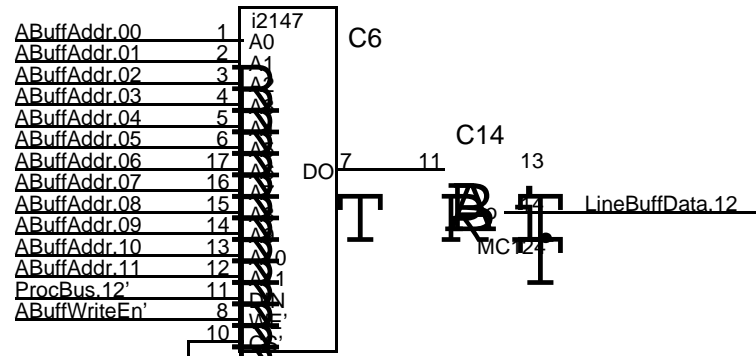
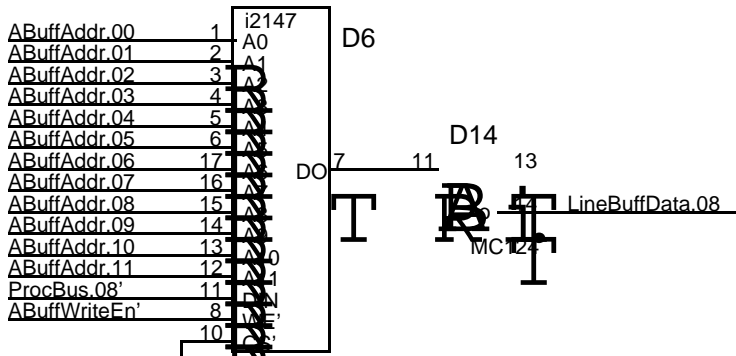

InputBEnable

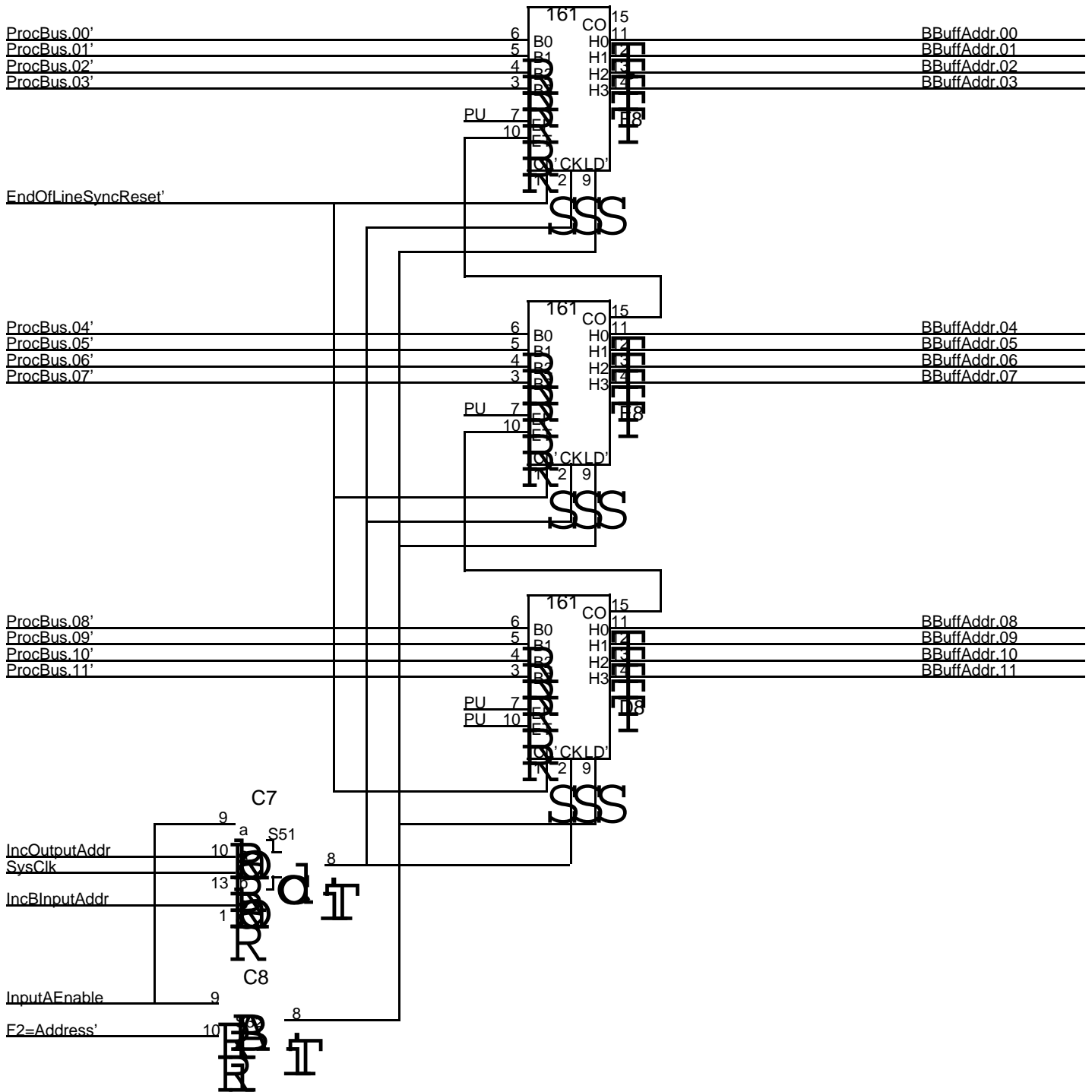

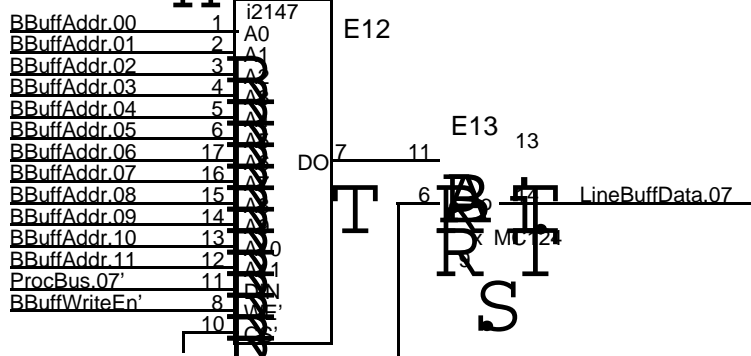
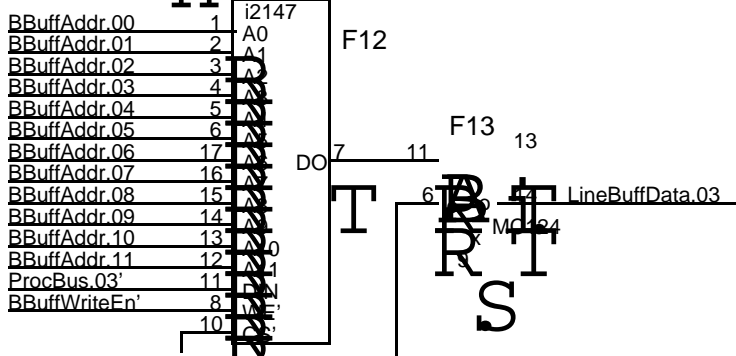
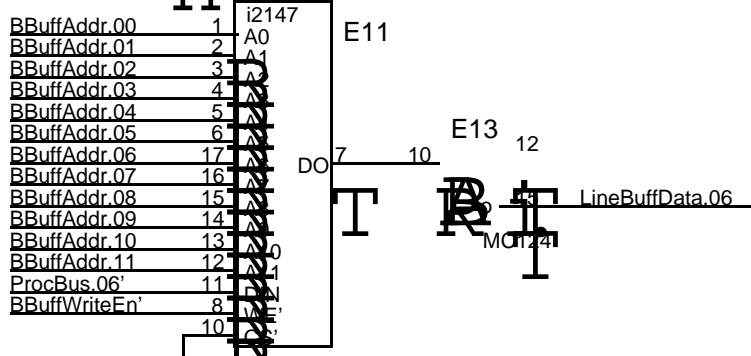
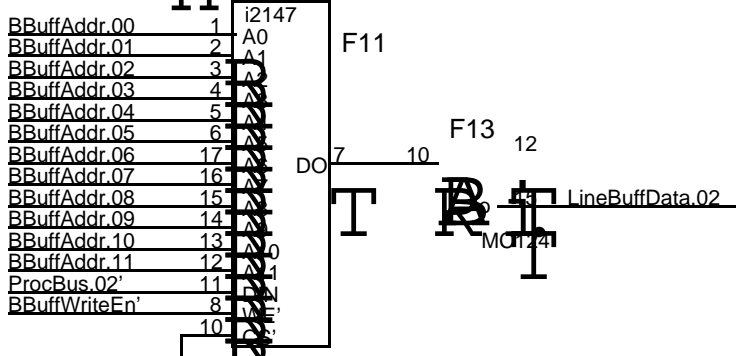
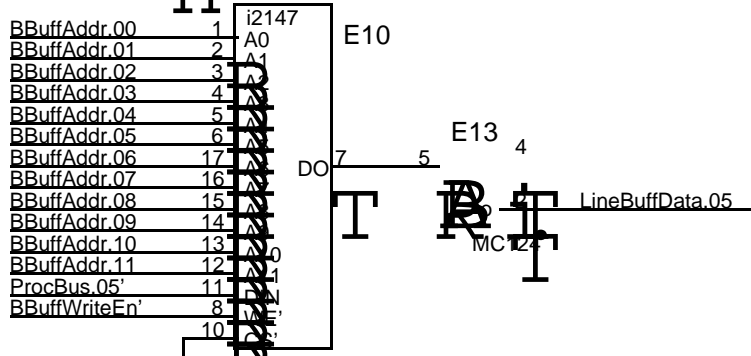
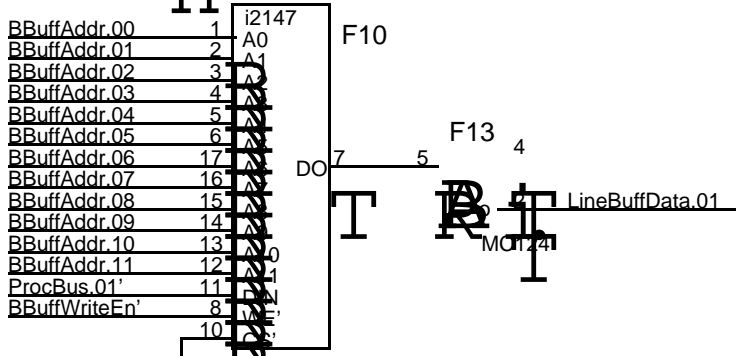
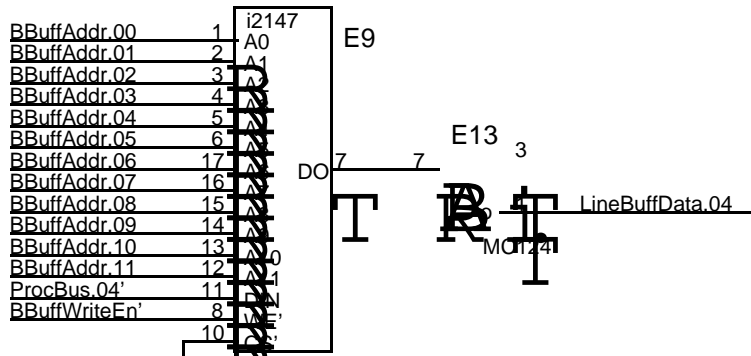
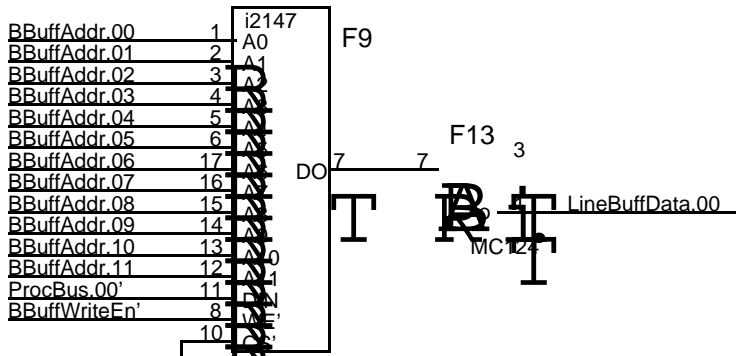

InputAEnable

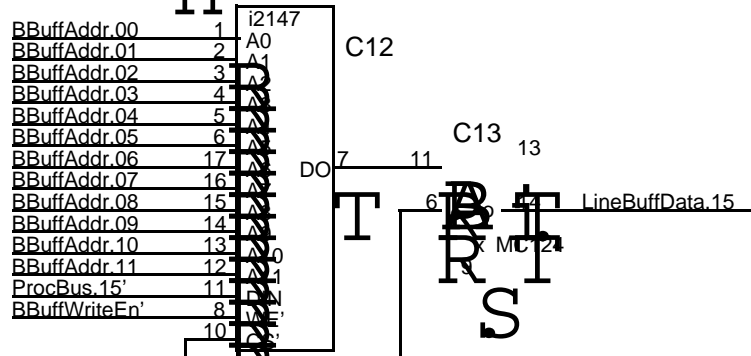
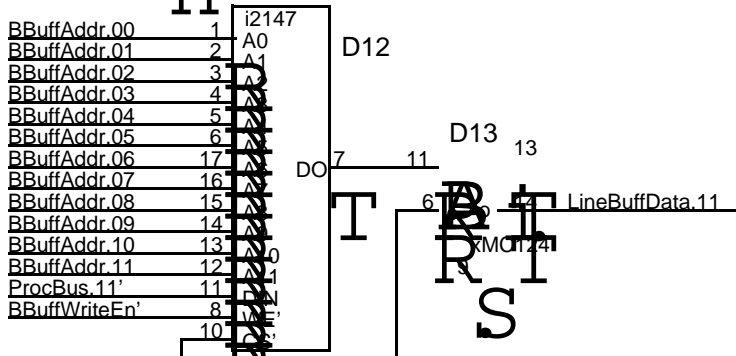
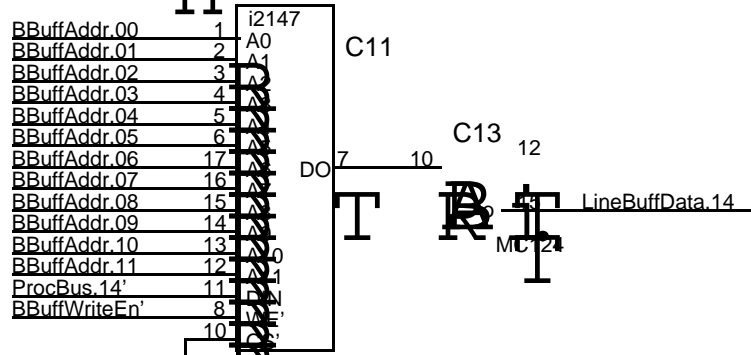
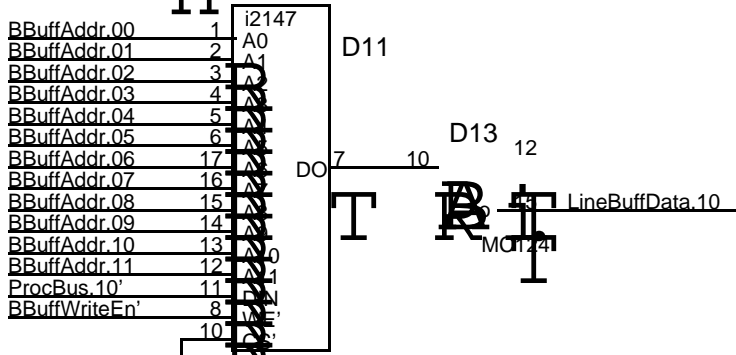
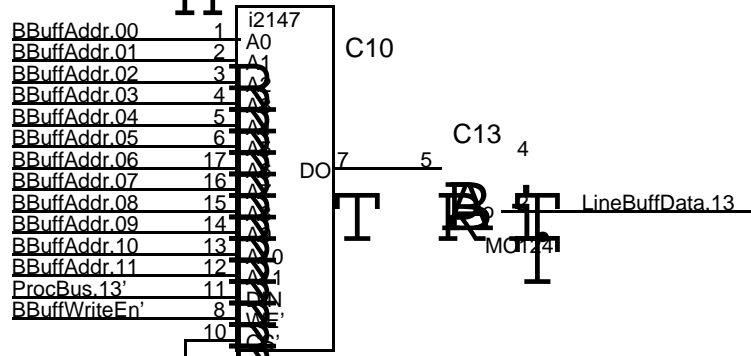
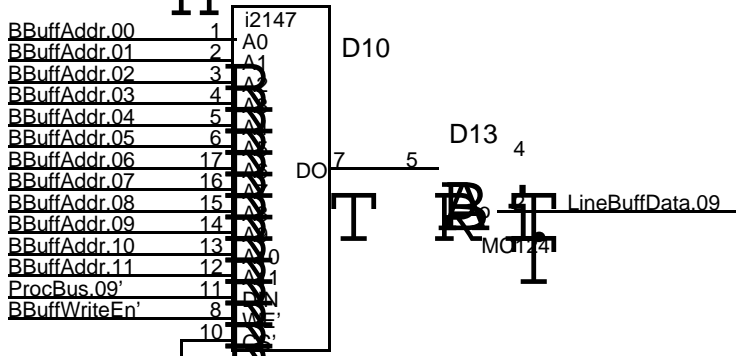
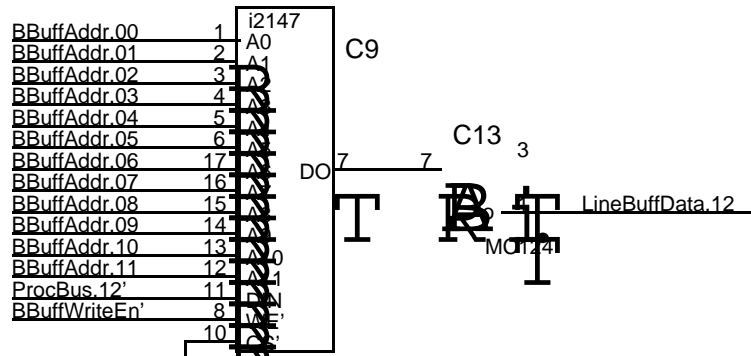
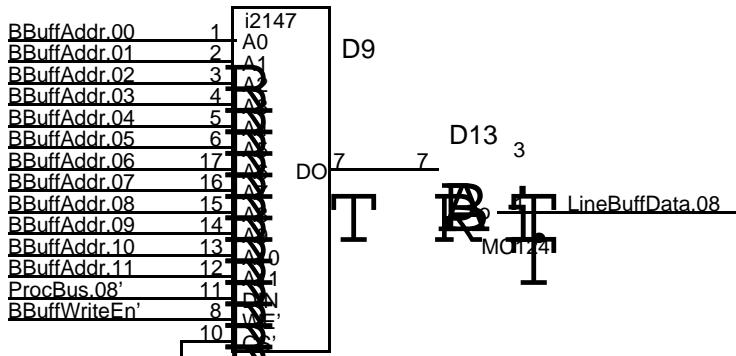

InputAEnable

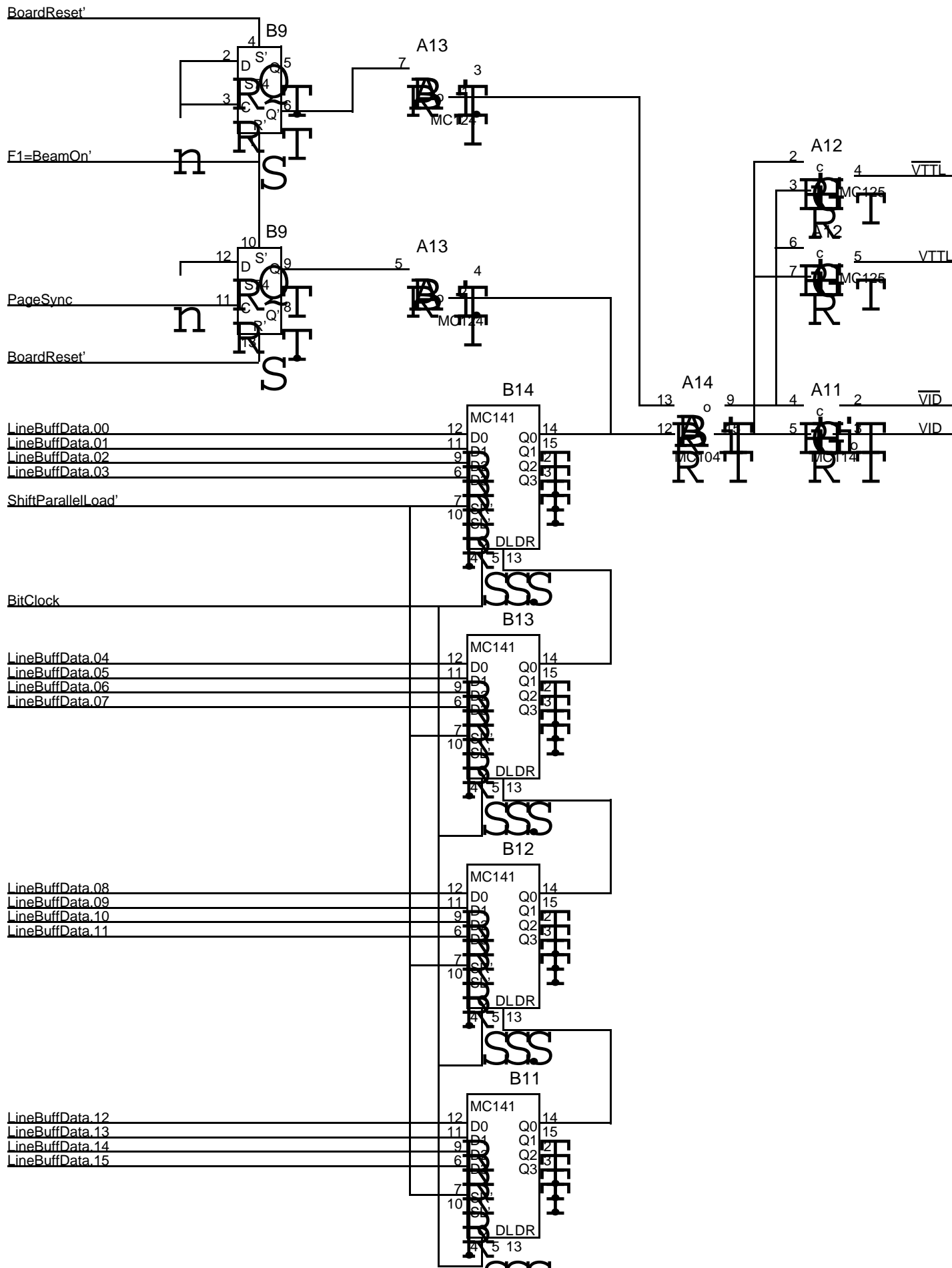

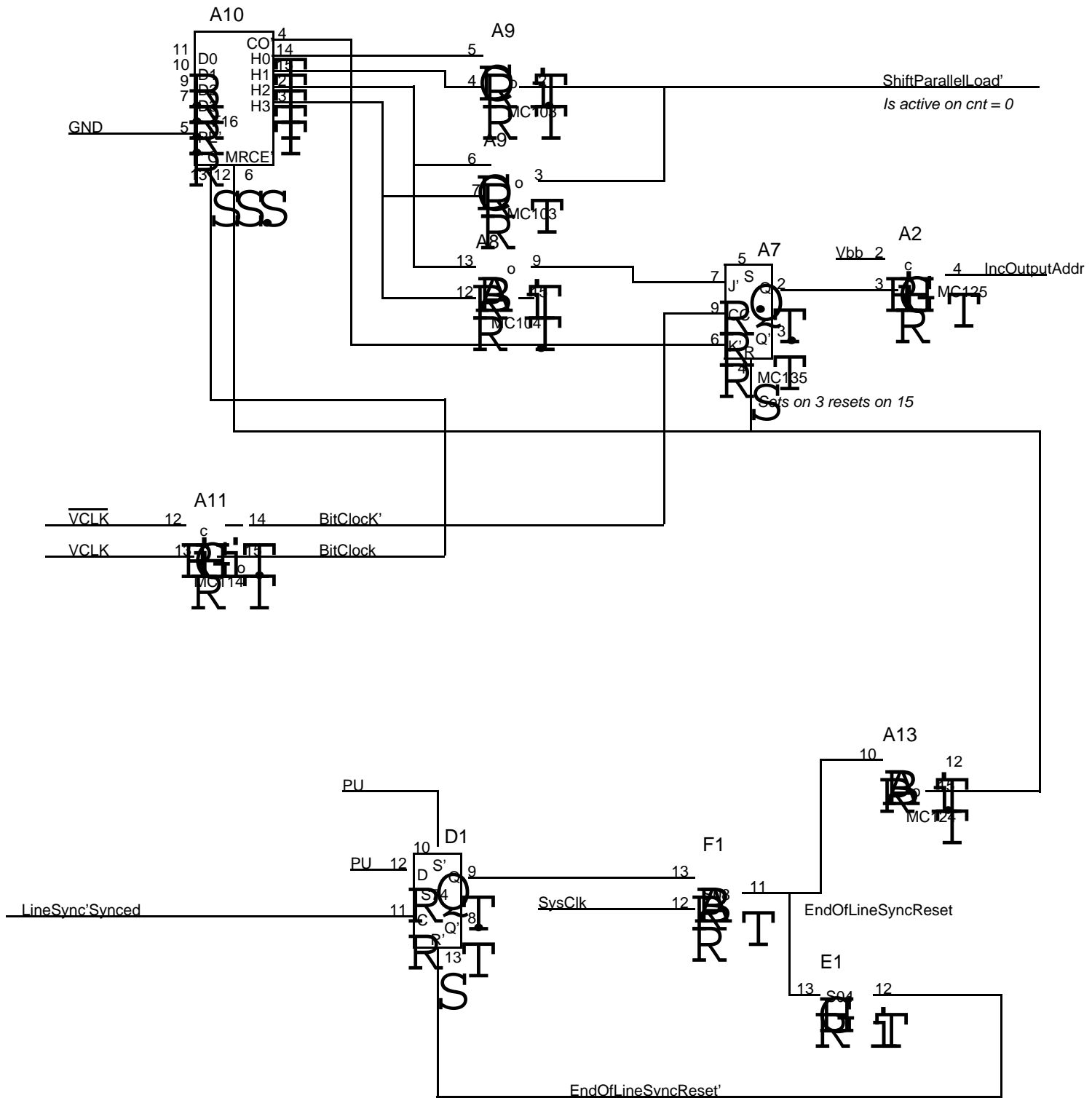

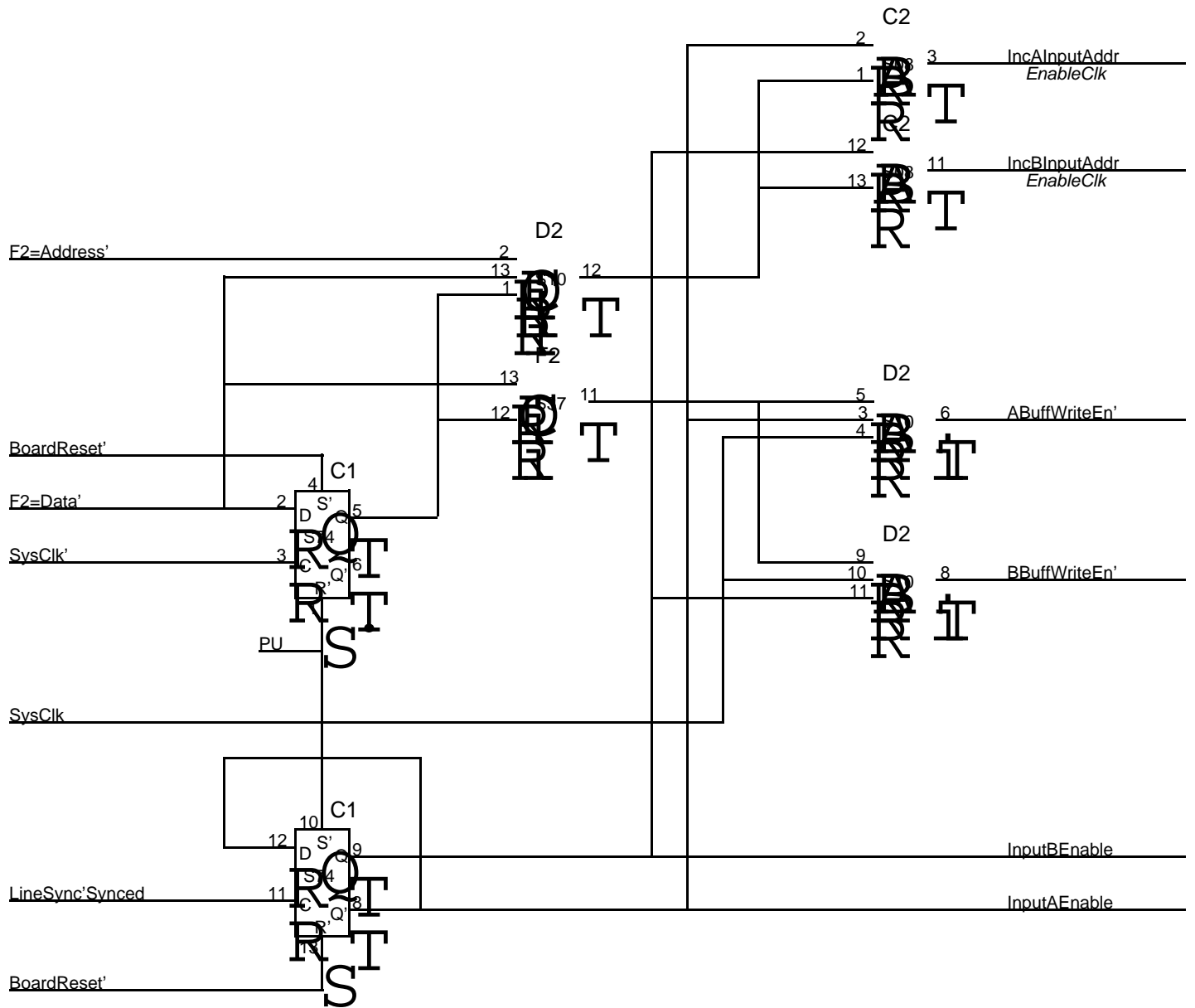

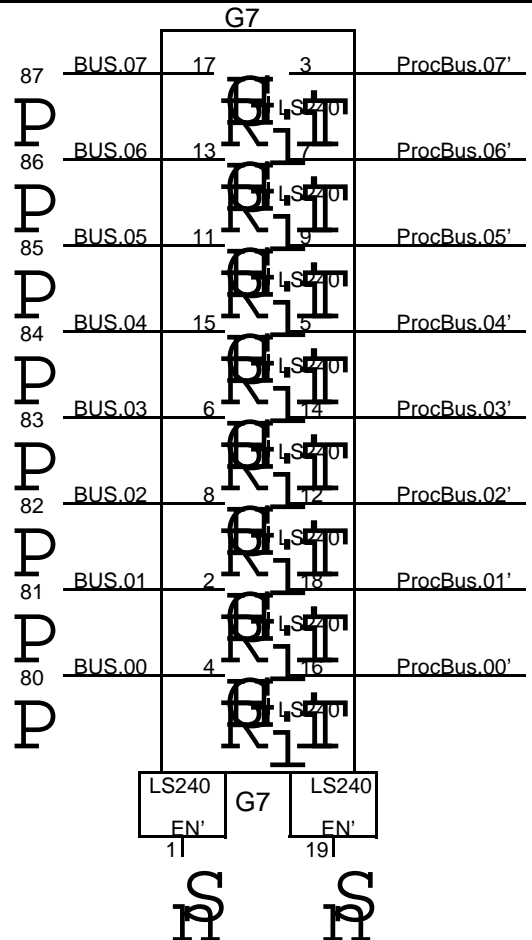
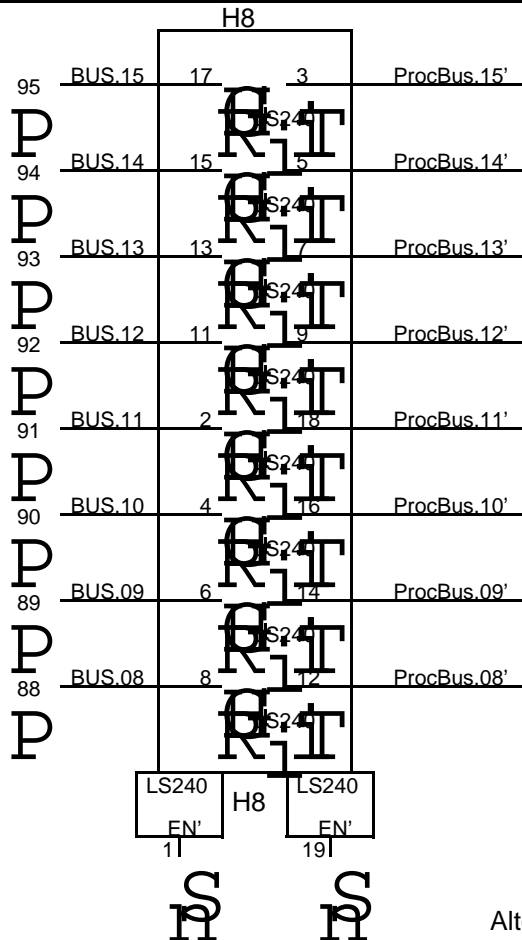
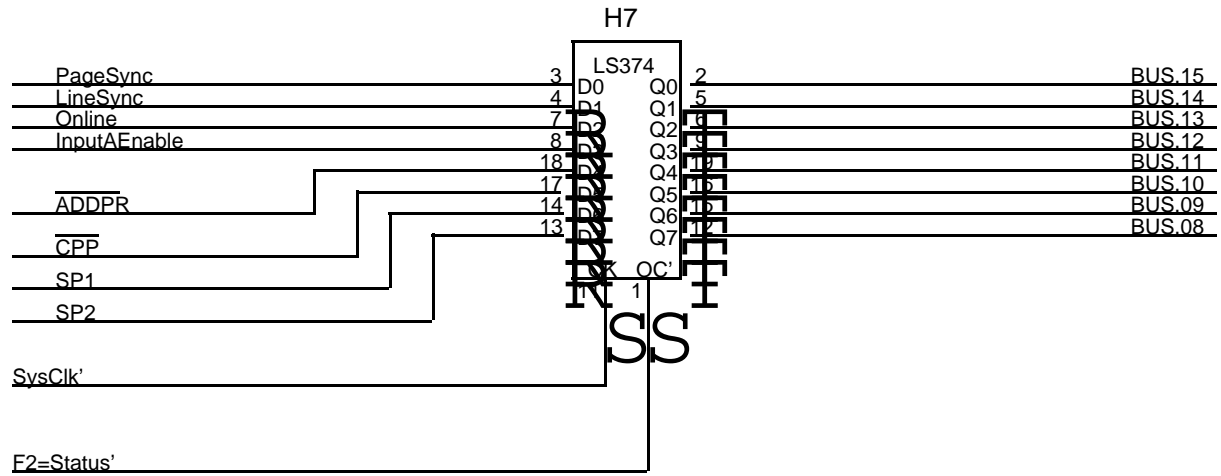

Alto Bus Interface

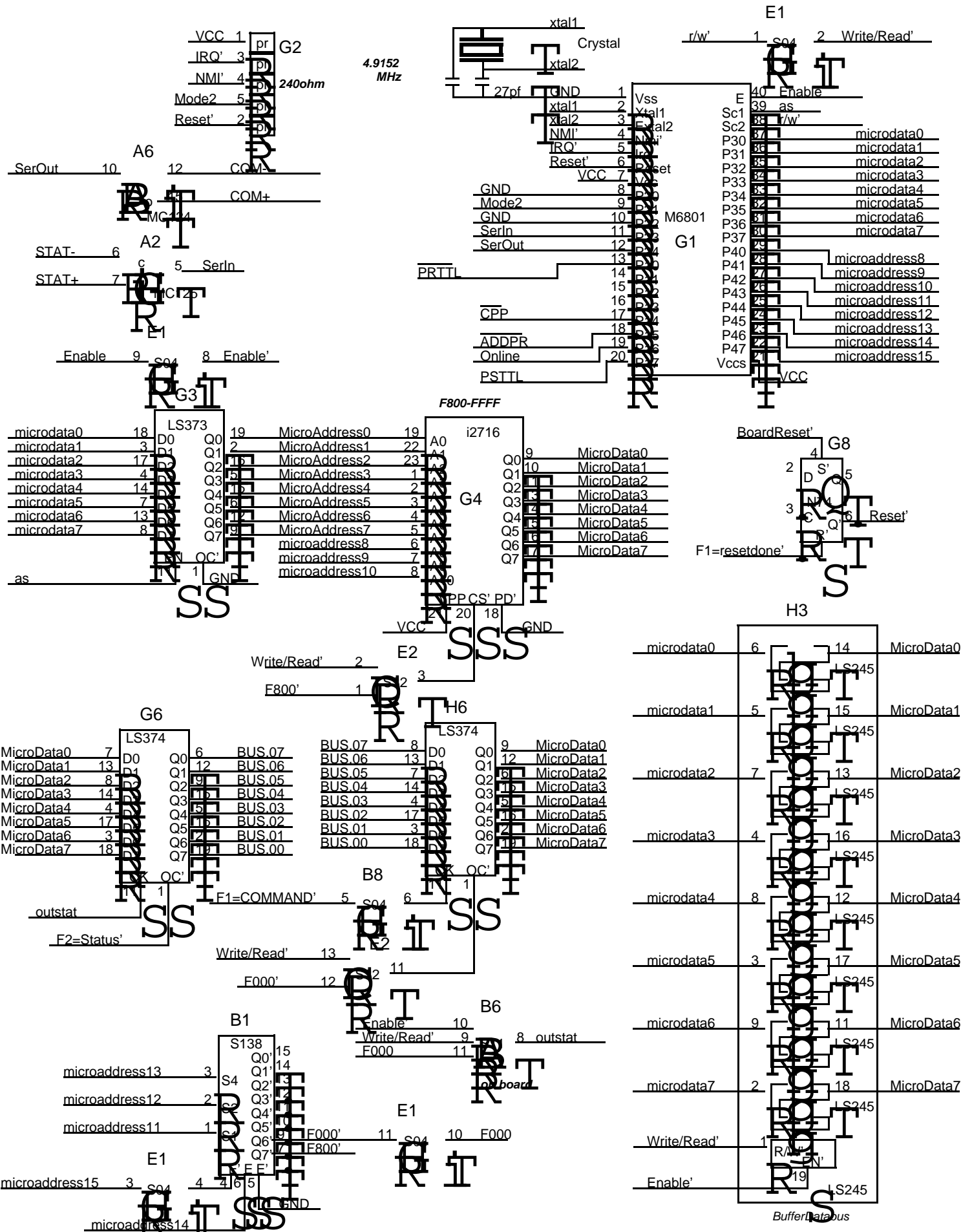

NOTE: RESET MUST BE 20MS AT POWERUP AND 3 CLOCK CYCLES OTHER TIMES.

XEROX	Project	File	Designer	Rev	Date	Page
PARC/CSL	Slot3 Processor, Bus Buffers, etc.	Slot17.sil	Dan putman rev: JEO	AG	7/27/83	15